

Valtek GS

General Service Control Valve

FCD VLENTB0300A4 03/14



Valtek GS - “General Service Control Valve”

The Valtek GS product line is low cost, compact and light-weight. Yet, it is rugged and can be used safely and confidently in a wide range of general service applications plant-wide. Its modularity provides trim and material options to suit most service situations. Simplicity of design reduces maintenance and parts inventory costs.

Ideally suited for flow and pressure control of liquid and gas media in oil and gas, power, chemical and petrochemical processing and related industries, the Valtek GS package provides flow rates, control accuracy and reliability at levels comparable to special engineered service control valves, but at a significantly lower total cost.

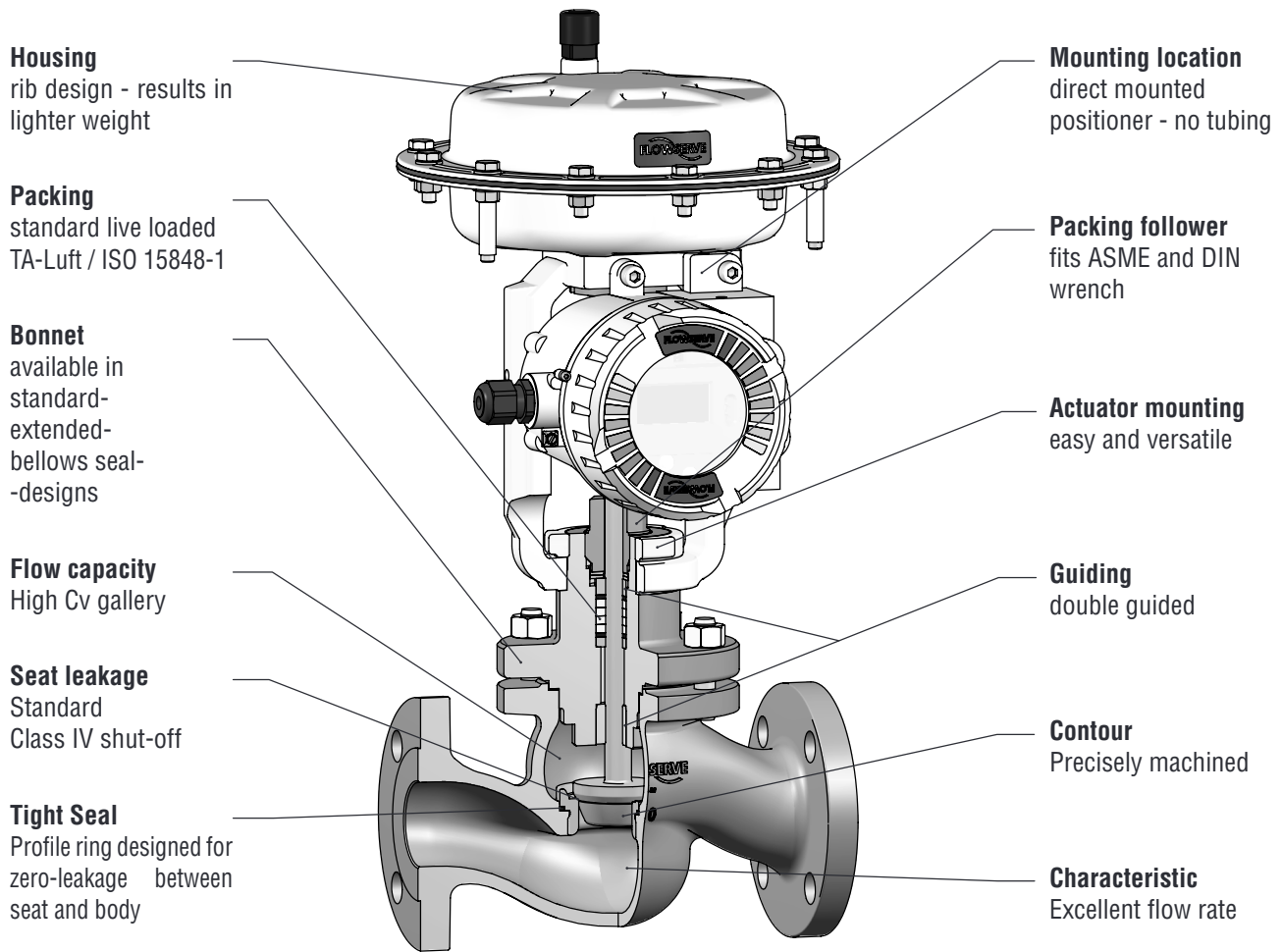

Specifications

Style	Globe, ASME and DIN
Sizes	½ to 6 inch / 15 to 150 mm
Pressure Classes	ASME 150 and 300 / PN 16 and PN 40
End Connection	Flanged
Body Materials	A216WCC / 1.0619 and A351CF8M / 1.4408
Face to Face	ISA 75.08.06 / EN 558-1 basic series 1
Bonnet	standard, extended, bellows seal
Packing	PTFE and Graphite spring loaded TA-Luft & ISO 15848-1

Trim material	316 stainless steel
Trim types	standard, pressure balanced
Plug & seat facing	standard, seat surface Alloy 6
Characteristic	= %, linear, quick open
Low noise and anti-cavitation	MultiStream 1-stage
Leakage rates	Class IV, V and VI (with optional soft seat)
Actuator	pneumatic diaphragm spring actuator
Standard positioner	Logix 420, direct mounted without tubing

Body Design - “Integral Flange”

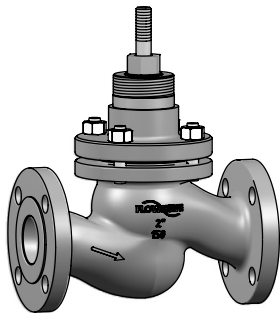
Body Design	Type (Body) / Size	Body Material	Bonnet Design	Packing Design	Trim Design
Integral flange	PN 16 40 DN 15 20 25 32 40 50 65 80 100 125 150 Class 150 300 NPS 1/2 3/4 1 1 1/2 2 3 4 6	 1.0619 1.4408 A216 WCC A351 CF8M	Unbalanced Standard Bonnet Bellow Seal Bonnet Extended Bonnet V-Ring pressure balanced Standard Bonnet Bellow Seal Bonnet Extended Bonnet Piston-Ring pressure balanced Bellow Seal Bonnet Extended Bonnet <i>see page 4 - 6</i>	spring loaded Teflon TA-Luft Graphite TA-Luft <i>see page 6</i>	Contoured Plug Standard Partial Hard Facing Contour Hard Facing Soft Seated Quick Open Standard Soft Seated Anti-noise Equipment MultiStream 1-stage <i>see page 7</i>

Body Connecting Design - “Detail”

Body Design	Face to Face		End Connections		
Integral flange	Raised Face	EN 558-1:2012-03 Basic Range 1	according to EN 1092-1	Form B1 - raised-face	Ra = 3,2 - 12,5 µm
		ASME / ISA 75.08.01-2002		Form F - recess	
			according to ASME B16.5	Raised-face RF	Ra = 3,2 - 6,3 µm 125 - 250 µin.

Body Pressure - Temperature Ratings

PN Class	Body Material	Maximum Allowable Working Pressure	Service Temperature in °C												
			- 60	- 46	- 29	- 10	50	100	150	200	250	300	350	400	
16	1.0619	bar			12,0	16,0	16,0	13,7	13,3	12,4	11,3	10,2	9,6	9,1	
	1.4408		16,0	16,0	16,0	16,0	15,1	13,7	12,7	11,9	11,0	10,5	10,2		
40	1.0619				30,0	40,0	40,0	34,2	33,3	31,0	28,3	25,7	24,1	22,8	
	1.4408		40,0	40,0	40,0	40,0	37,9	34,4	31,8	29,9	27,6	26,4	25,7		
150	A216 WCC				19,6	19,6	19,2	17,7	15,8	13,8	12,1	10,2	8,4	6,5	
	A351 CF8M		19,0	19,0	19,0	19,0	18,4	16,2	14,8	13,7	12,1	10,2	8,4	6,5	
300	A216 WCC				51,1	51,1	51,1	46,6	45,1	43,8	41,9	39,8	37,6	34,7	
	A351 CF8M		49,6	49,6	49,6	49,6	48,1	42,2	38,5	35,7	33,4	31,6	30,3	29,4	
Class				Service Temperature in °F											
				- 76	- 51	- 20	14	122	212	302	392	482	572	662	752
150	A216 WCC		psig			284	284	278	257	229	200	176	148	122	94
	A315 CF8M			276	276	276	276	267	235	215	199	176	148	122	94
300	A216 WCC				741	741	741	676	654	635	608	577	545	503	
	A351 CF8M	719		719	719	719	698	612	558	518	484	458	439	426	

Working Temperature Range dependent on Body / Bonnet / Trim / Packing

Body Material	Bonnet Design	Trim Material MAWT ¹⁾	Packing Material			
			Teflon - TA-Luft		Graphite - TA-Luft	
			°C	°F	°C	°F
1.0619 A216 WCC	Standard Bonnet	316 SS	- 29 to + 250	- 20 to + 482	-	-
	Bellows Seal Bonnet		- 29 to + 300	- 20 to + 572	+ 300 to + 400	+ 572 to + 752
	Extended Bonnet		+ 250 to + 300	+ 482 to + 572	+ 300 to + 400	+ 572 to + 752
	Standard Bonnet V-Ring pressure balanced		- 29 to + 250	- 20 to + 482	-	-
	Bellows Seal Bonnet V-Ring pressure balanced		- 29 to + 250	- 20 to + 482	-	-
	Extended Bonnet V-Ring pressure balanced		- 29 to + 250	- 20 to + 482	-	-
	Bellows Seal Bonnet Piston-Ring pressure balanced		+ 250 to + 300	+ 482 to + 572	+ 300 to + 400	+ 572 to + 752
	Extended Bonnet Piston-Ring pressure balanced		+ 250 to + 300	+ 482 to + 572	+ 300 to + 400	+ 572 to + 752
1.4408 A351 CF8M	Standard Bonnet		- 46 to + 250	- 51 to + 482	-	-
	Bellows Seal Bonnet		- 60 to + 300	- 76 to + 572	+ 300 to + 400	+ 572 to + 752
	Extended Bonnet		+ 250 to + 300	+ 482 to + 572	+ 300 to + 400	+ 572 to + 752
	Standard Bonnet V-Ring pressure balanced		- 46 to + 250	- 51 to + 482	-	-
	Bellows Seal Bonnet V-Ring pressure balanced		- 60 to + 250	- 76 to + 482	-	-
	Extended Bonnet V-Ring pressure balanced		- 60 to + 250	- 76 to + 482	-	-
	Bellows Seal Bonnet Piston-Ring pressure balanced		+ 250 to + 300	+ 482 to + 572	+ 300 to + 400	+ 572 to + 752
	Extended Bonnet Piston-Ring pressure balanced		+ 250 to + 300	+ 482 to + 572	+ 300 to + 400	+ 572 to + 752

¹⁾ Maximal Allowable Working Temperature with PTFE soft seat = - 60 to + 250 °C / - 76 to + 482 °F only !

Bonnet Design - “Unbalanced” for DN 15 to 150 / NPS ½ to 6

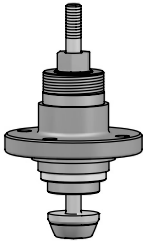
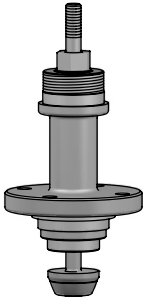
Bonnet Design	Type (Bonnet)	Body / Bonnet Material	Temperature Range ¹⁾	Application	Packing Design
Unbalanced	 Standard Bonnet	dependent on body material 1.0619 / 1.0460 A216 WCC / A216 WCC	- 29 to + 250 °C - 20 to + 482 °F	Universal use	spring loaded Teflon TA-Luft <i>see page 6</i>
		dependent on body material 1.4408 / 1.4408 A351 CF8M / A351 CF8M	- 46 to + 250 °C - 51 to + 482 °F		
Unbalanced	 Extended Bonnet	dependent on body material 1.0619 / 1.0619 A216 WCC / A216 WCC	+ 250 to + 300 °C + 482 to + 572 °F	Universal use dependent on temperature	spring loaded Teflon TA-Luft
		dependent on body material 1.0619 / 1.0619 A216 WCC / A216 WCC	+ 301 to + 400 °C + 573 to + 752 °F		spring loaded Graphite TA-Luft
		dependent on body material 1.4408 / 1.4408 A351 CF8M / A351 CF8M	- 60 to + 300 °C - 76 to + 572 °F		spring loaded Teflon TA-Luft
		dependent on body material 1.4408 / 1.4408 A351 CF8M / A351 CF8M	+ 301 to + 400 °C + 573 to + 752 °F		spring loaded Graphite TA-Luft

¹⁾ see also Working Temperature Range on Page 4

Bonnet Design - “Unbalanced” for DN 15 to 150 / NPS ½ to 6

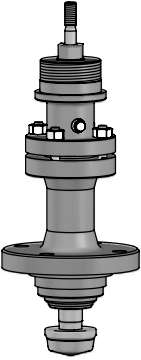
Bonnet Design	Type (Bonnet)	Body / Bonnet Material	Temperature Range	Application	Packing Design
Unbalanced	 Bellows Seal Bonnet	dependent on body material 1.0619 / 1.0619 A216 WCC / A216 WCC	- 29 to + 300 °C - 20 to + 572 °F	Use for hazardous, costly media or vacuum	spring loaded Teflon TA-Luft <i>see page 6</i>
		dependent on body material 1.4408 / 1.4408 A351 CF8M / A351 CF8M	- 60 to + 300 °C - 76 to + 572 °F		
		dependent on body material 1.0619 / 1.0619 1.4408 / 1.4408 A216 WCC / A216 WCC A351 CF8M / A351 CF8M	+ 300 to + 400 °C + 572 to + 752 °F		spring loaded Graphite TA-Luft <i>see page 6</i>

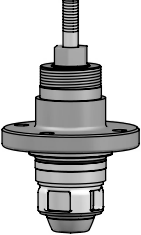
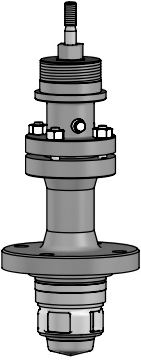
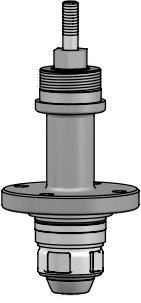

Bonnet Design - “Pressure balanced” for DN 80 to 150 / NPS 3 to 6

Bonnet Design	Type (Bonnet)	Body / Bonnet Material	Temperature Range	Application	Packing Design
V-Ring pressure balanced	 Standard Bonnet	dependent on body material 1.0619 / 1.0619 A216 WCC / A216 WCC	- 29 to + 250 °C - 20 to + 482 °F	Universal use	spring loaded Teflon TA-Luft <i>see page 6</i>
		dependent on body material 1.4408 / 1.4408 A351 CF8M / A351 CF8M	- 46 to + 250 °C - 51 to + 482 °F		
	 Bellows Seal Bonnet	dependent on body material 1.0619 / 1.0619 A216 WCC / A216 WCC	- 29 to + 250 °C - 20 to + 482 °F	Use for hazardous, costly media or vacuum	
 Extended Bonnet	dependent on body material 1.4408 / 1.4408 A351 CF8M / A351 CF8M	- 60 to + 250 °C - 76 to + 482 °F	Universal use dependent on temperature		

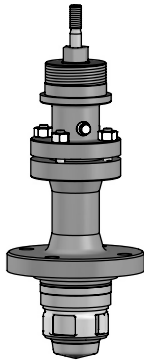
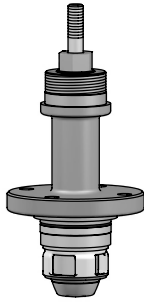
Bonnet Design - "Pressure balanced" for DN 80 to 150 / NPS 3 to 6

Bonnet Design	Type (Bonnet)	Body / Bonnet Material	Temperature Range	Application	Packing Design
Piston-Ring pressure balanced	Bellows Seal Bonnet 	dependent on body material 1.0619 / 1.0619 1.4408 / 1.4408	+ 250 to + 400 °C + 482 to + 752 °F <i>see also Working Temperature Range on Page 4</i>	Use for hazardous, costly media or vacuum	spring loaded Graphite TA-Luft <i>see page 6</i>
	Extended Bonnet 	A216 WCC / A216 WCC A351 CF8M / A351 CF8M		Universal use dependent on temperature	

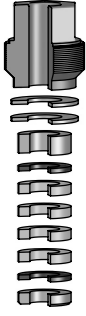
Packing Design - "Detail"

Packing Design	Type (Packing)	Material	Temperature Range	Application	Approvals
spring loaded		Packing Rings Braided PTFE-Yarn impregnated with PTFE-Dispersion Chamber Washers PTFE-Carbon	- 60 to + 300 °C - 76 to + 572 °F <i>see also Working Temperature Range on Page 4</i>	Universal chemical resistance.	TA-Luft ISO 15848-1 (10 ⁻⁴ mg * s ⁻¹ * m ⁻¹) Tightness class -> B Endurance class -> CC1
		Packing Rings Braided Graphite made out of expanded pure Graphite-Yarn lubricated with a slip additive	301 to + 400 °C 573 to + 752 °F <i>see also Working Temperature Range on Page 7</i>	Universal chemical resistance. Not suitable for oxidizing medium !	TA-Luft ISO 15848-1 (10 ⁻² mg * s ⁻¹ * m ⁻¹) Tightness class -> C Endurance class -> CC1

Trim Design - "Standard"

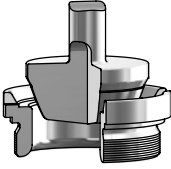
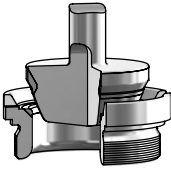
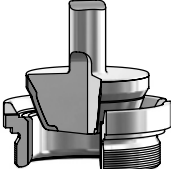
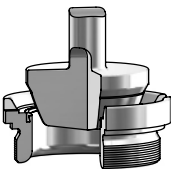
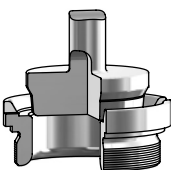
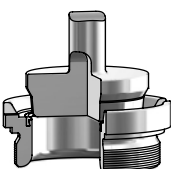
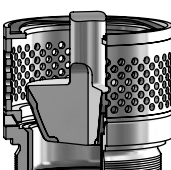
Type (Trim) / Material		Medium		Flow	max. allowable Differential Pressure in bar ¹⁾	Noise Reduction
Contoured Plug Characteristic: mod. equal per. or linear	standard 316 SS 	<ul style="list-style-type: none"> clean marginally contaminated with particles low clogging potential for dirty service 	gases, vapors and liquids	Flow direction under the plug	$\Delta p_1 < x_{FZ} \cdot (p_1 - p_v)$ $\Delta p_c < x_T \cdot p_1$	none - Noise Insulating provided by customer
	partial hard facing (seat surface) 316 SS from seat Ø 12 mm 				$\Delta p_1 < (x_{FZ} + 0,10) \cdot (p_1 - p_v)$ $\Delta p_c < x_T \cdot p_1$	
	full hard facing (contour) 316 SS up to seat Ø 10 mm 				$\Delta p_1 < (x_{FZ} + 0,15) \cdot (p_1 - p_v)$ $\Delta p_c < x_T \cdot p_1$	
	soft seated 316 SS + PTFE 				$\Delta p_1 < x_{FZ} \cdot (p_1 - p_v)$ $\Delta p_c < x_T \cdot p_1$	
Quick Open with Throttle Lip Characteristic: On / Off	standard 316 SS 				$\Delta p < MAWP$	
	soft seated 316 SS + PTFE 					
Contoured Plug with MultiStream	all Standard Trim 		Gases and Vapors		Type: standard $\Delta p_c < x_T \cdot p_1$	max. - 13 dB(A)
			Liquids		Type: standard soft seated $\Delta p_1 < x_{FZ} \cdot (p_1 - p_v)$ Type: partial hard facing $\Delta p_1 < (x_{FZ} + 0,10) \cdot (p_1 - p_v)$ Type: full hard facing $\Delta p_1 < (x_{FZ} + 0,15) \cdot (p_1 - p_v)$	max. - 4 dB(A)
Characteristic values of incompressible fluids $\Delta p_1 \rightarrow x_{FZ} \rightarrow 0,79 - 0,24$ respectively compressible fluids $\Delta p_c \rightarrow x_T \rightarrow 0,82 - 0,61$						

¹⁾ Formulas works only with SI - values (bar = psi / 14.5038) !

Valve Characteristic

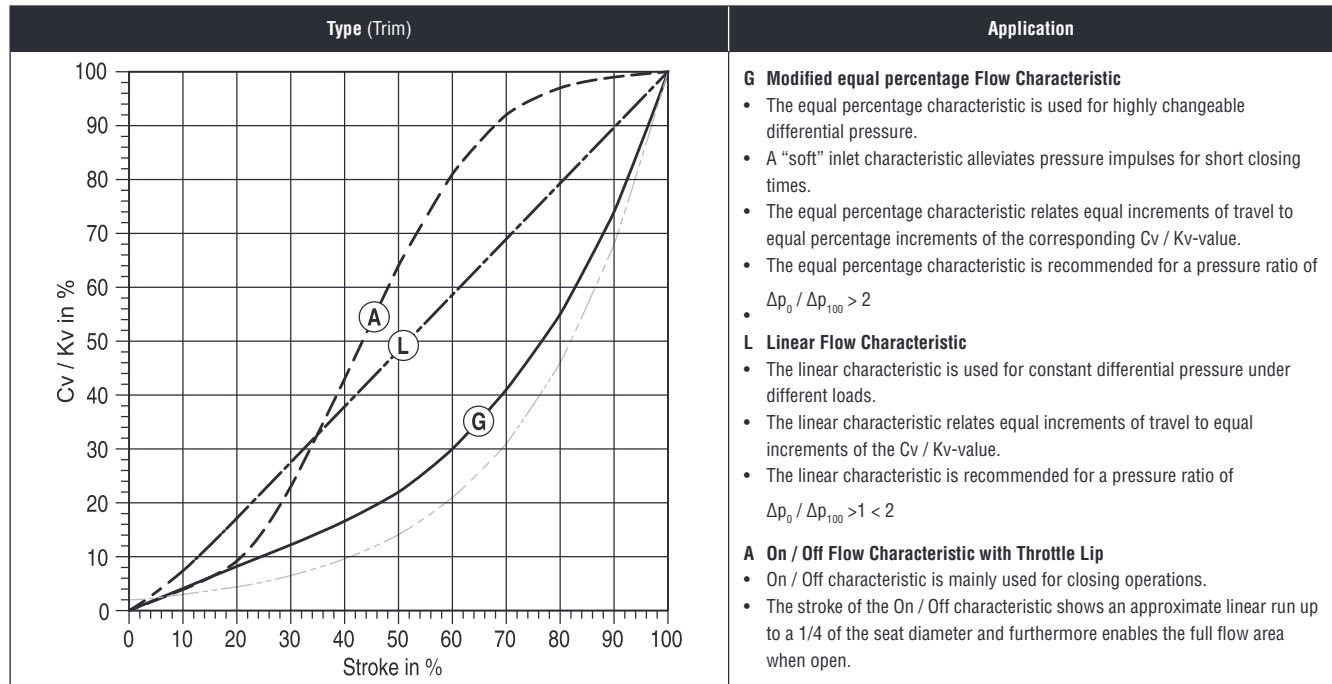

Contoured Plug

Characteristic: modified - equal percentage resp. linear

Cv (gpm)	kvs (m ³ /h)	Seat Ø	Balancing	Material / Design				Possible seat diameter depends on nominal size												
				316 SS				15	20	25	32	40	50	65	80	100	125	150		
				standard	partial hard facing	full hard facing	soft seated ¹⁾	1/2"	3/4"	1"	3/4"	1 1/2"	2"	65	80	100	125	150		
				Stroke = 20 mm / 0.787 in.						40 mm / 1.574 in.				60 mm / 2.362 in.						
0.46	0,40	4		•		•	•	•	•	•										
0.73	0,63	6		•		•	•	•	•	•										
1.16	1,0	8		•		•	•	•	•	•										
1.8	1,6	8		•		•	•	•	•	•										
2.9	2,5	10		•		•	•	•	•	•										
4.6	4,0	12		•	•		•	•	•	•										
6.5	5,6	16		•	•		•	•	•	•										
7.3	6,3	16		•	•		•	•	•	•										
9.2	8,0	20		•	•		•	•	•	•										
11.6	10	20		•	•		•	•	•	•										
16.2	14	25		•	•		•	•	•	•										
18.5	16	25		•	•		•	•	•	•										
-	22,4	34		•	•		•	•	•	•										
29	25	34		•	•		•	•	•	•										
36	31,5	40		•	•		•	•	•	•										
46	40	42		•	•		•	•	•	•										
55	47,5	50		•	•		•	•	•	•										
73	63	53		•	•		•	•	•	•										
-	80	67		•	•		•	•	•	•										
116	100	67	•	•	•		•	•	•	•										
145	125	80	•	•	•		•	•	•	•										
185	160	84	•	•	•		•	•	•	•										
208	180	100	•	•	•		•	•	•	•										
289	250	105	•	•	•		•	•	•	•										
410	355	130	•	•	•		•	•	•	•										

¹⁾ Maximal Allowable Working Temperature with PTFE soft seat = - 60 to + 250 °C / - 76 to + 482 °F only !

Contoured Plug linked to MultiStream

Characteristic: modified - equal percentage resp. linear

CV (gpm)	kvs (m ³ /h)	Seat Ø	Balanc- ing	Material / Design			Possible seat diameter depends on nominal size											
				316 SS			15	20	25	32	40	50	65	80	100	125	150	
				standard	partial hard facing	soft seated ¹⁾	1/2"	3/4"	1"	1 1/2"	2"	2"	3"	4"	4"	6"	6"	
							Stroke = 20 mm / 0.787 in.				40 mm / 1.574 in.			60 mm / 2.362 in.				
4.6	4,0	16		•	•	•	•											
5.8	5,0	16		•	•	•		•										
6.5	5,6	16		•	•	•			•									
7.3	6,3	20		•	•	•		•										
9.2	8,0	20		•	•	•			•									
10.4	9,0	20		•	•	•			•	•								
11.6	10	25		•	•	•			•									
-	12,5	25		•	•	•			•									
16.2	14	25		•	•	•				•	•							
-	16	34		•	•	•			•									
23	20	34		•	•	•				•								
26	22,4	34		•	•	•					•							
29	25	40		•	•	•				•								
36	31,5	42		•	•	•					•							
41	35,5	42		•	•	•					•	•						
41	35,5	50		•	•	•					•							
-	50	53		•	•	•					•							
65	56	53		•	•	•						•	•					
-	63	67	•	•	•	•					•							
92	80	67	•	•	•	•						•	•					
104	90	67	•	•	•	•								•		•		
104	90	80	•	•	•	•						•						
145	125	84	•	•	•	•							•					
162	140	84	•	•	•	•									•		•	
162	140	100	•	•	•	•							•					
-	180	105	•	•	•	•										•		
231	200	105	•	•	•	•												•
324	280	130	•	•	•	•												•

¹⁾ Maximal Allowable Working Temperature with PTFE soft seat = - 60 to + 250 °C / - 76 to + 482 °F only !

Quick Open

Characteristic: on / off

CV (gpm)	kvs (m ³ /h)	Seat Ø	Material / Design		Possible seat diameter depends on nominal size													
			316 SS		15	20	25	32	40	50	65	80	100	125	150			
			standard	soft seated ¹⁾	1/2"	3/4"	1"	1 1/2"	2"	2"	3"	4"	4"	6"	6"			
					Stroke = 20 mm / 0.787 in.				40 mm / 1.574 in.			60 mm / 2.362 in.						
7.3	6,3	16	•	•	•													
10.4	9,0	20	•	•		•												
18.5	16	25	•	•			•											
-	25	34	•	•				•										
41	35,5	40	•	•					•									
61	53	50	•	•						•								
-	90	67	•	•							•							
162	140	80	•	•								•						
231	200	100	•	•									•					
-	285	105	•	•												•		
462	400	130	•	•														•

¹⁾ Maximal Allowable Working Temperature with PTFE soft seat = - 60 to + 250 °C / - 76 to + 482 °F only !

Seat Leakage

¹⁾ Ø d = Seat Ø
²⁾ LF = Leakage Factor → see IEC 60534-4 Remark 2

acc. Standard	Balancing	Plug design	Leakage Class	Test Medium	Test Pressure	max. Seat Leakage	Leakage Code
IEC 60534-4:2006-06 resp. ASME / FCI 70-2	Without	metal to metal seated	IV	Liquid	Working Pressure	0,000 1 · kvs 0,000 1 · cv	IV L 2
				Gas	Working Pressure, max. 3,5 bar	0,000 1 · kvs	
			Working Pressure, max. 50.7 psi		0,000 1 · cv		
		metal to metal seated, lapped seat, increased seal force	V	Liquid	Working Pressure	0,000 018 · Δp · Ø d ¹⁾	V L 2
				Gas	Working Pressure, max. 3,5 bar	0,000 010 8 · Ø d	V G 1
			Working Pressure, max. 50.7 psi				
	soft seated	VI	Gas	Working Pressure, max. 3,5 bar	0,3 · Δp · LF ²⁾	VI G 1	
				Working Pressure, max. 50.7 psi			
	V-Ring	metal to metal seated	IV	Liquid	Working Pressure	0,000 1 · kvs 0,000 1 · cv	IV L 2
				Gas	Working Pressure, max. 3,5 bar	0,000 1 · kvs	
					Working Pressure, max. 50.7 psi	0,000 1 · cv	
			metal to metal seated, lapped seat, increased seal force	V	Liquid	Working Pressure	0,000 018 · Δp · Ø d
		Gas			Working Pressure, max. 3,5 bar	0,000 010 8 · Ø d	V G 1
				Working Pressure, max. 50.7 psi			
		soft seated	VI	Gas	Working Pressure, max. 3,5 bar	0,3 · Δp · LF	VI G 1
					Working Pressure, max. 50.7 psi		
Piston-Ring		metal to metal seated	IV	Liquid	Working Pressure	0,000 1 · kvs	IV L 2
						0,000 1 · cv	
EN 12266-1:2003-06	Without	metal to metal seated	A	Liquid	Working Pressure · 1,1	no leakage viewable	-
		metal to metal seated, lapped seat			Working Pressure, max. 6 bar		
		soft seated		Gas	Working Pressure, max. 87.0 psi		
					Working Pressure, max. 6 bar		
		Working Pressure, max. 87.0 psi					

Max. allowable control - differential pressure

Seat Ø	Δ p (bar / psi)																						
	15 1/2"		20 3/4"		25 1"		32		40 1 1/2"		50 2"		65		80 3"		100 4"		125		150 6"		
	Stroke 20 mm / 0.787 in.						40 mm / 1.574 in.						60 mm / 2.362 in.										
	Stem Ø 12 mm / 0.472 in. max. Force 13 500 N / 3035 lbf				Stem Ø 16 mm / 0.630 in. max. Force 23 000 N / 5171 lbf				Stem Ø 20 mm / 0.787 in. max. Force 39 000 N / 8768 lbf				Stem Ø 24 mm / 0.945 in. m. F. 56 000 N / 12 590 lbf										
unbalanced	4	51	740	51	740	51	740																
	6	51	740	51	740	51	740																
	8	51	740	51	740	51	740																
	10	51	740	51	740	51	740																
	12	51	740	51	740	51	740																
	16	51	740	51	740	51	740																
	20			51	740	51	740	51	740	51	740												
	25					51	740	51	740	51	740	51	740										
	34							51	740	51	740	51	740										
	40									48	696												
	42											44	638	51	740	51	740						
	50											32	464										
	53													32	464	32	464	32	464				
	67													20	290	20	290	20	290	24	348	24	348
	80															15	218						
	84																	13	189	15	218	15	218
100																	10	145					
105																				10	145	10	145
130																						7	102
pressure balanced	67														51	740	51	740	51	740	51	740	
	80														51	740							
	84																51	740	51	740	51	740	
	100																51	740					
	130																			51	740	51	740

Parts List

Materials of Construction

Item		Part	Available Materials			
WW	EU					
1	1.1	Body	1.0619	A216 WCC	1.4408	A351 CF8M
58	1.2	Bonnet Gasket	Pure Graphite on Support Plate from 1.4401			
108	1.3	Stud Bolt	KG	A193	A2-70	A193
114	1.4	Hex Nut	KG	A194	A2-70	A194
20	2.1	Seat Ring	316 SS			
50	2.2	Contoured Plug Quick Open	316 SS			
8	2.3	Lock Bushing	316 SS			
6	2.4	Bellows seal Unit	316 SS			
55	2.5	Profile Ring	Pure Graphite			
113	2.6	Hex Nut ¹⁾	316 SS			
91	2.7	Seal Carrier ¹⁾	316 SS			
60	2.8	Profile Ring ¹⁾	Pure Graphite			
31	2.9	Cage ²⁾	A351 CF8M			
56	2.10	Cage Gasket ¹⁾	Pure Graphite			
65	2.12	Sealing Ring ¹⁾	PTFE-Rings			
59	2.15	Head Gasket	Pure Graphite			
66	2.21	Driving Band ¹⁾	PTFE			
30	2.26	Multi. Cylinder ¹⁾	1.4571			
133	2.28	Spring ¹⁾	1.4568			
40	3.1	Standard Bonnet Extension Bonnet Bellows Seal Bonnet	1.0460 or 1.0619	A105 or A216 WCC	1.4404 or 1.4408	316 L or A351 CF8M
83	3.1.1	Lower Stem Guide	316 SS (tenifer treated)			
93	3.2	Bottom Ring	316 SS			
88	3.3	Packing	PTFE-Rings Graphite-Rings			
80	3.4	Packing Follower	316 SS			
87	3.6	Upper Stem Guide	316 SS (tenifer treated)			
109	3.7	Belleville Spring	1.4310			
48	3.13	Gasket	Pure Graphite			
42	3.14	Plug Screw	A2			
7	3.15	Head	1.0460 or 1.0619	A105 or A216 WCC	1.4404 or 1.4408	316 L or A351 CF8M
110	3.16	Hex Nut	KG	A194	A2-70	A194
106	3.17	Stud Bolt	KG	A193	A2-70	A193

¹⁾ Parts not illustrated, see User Manual !

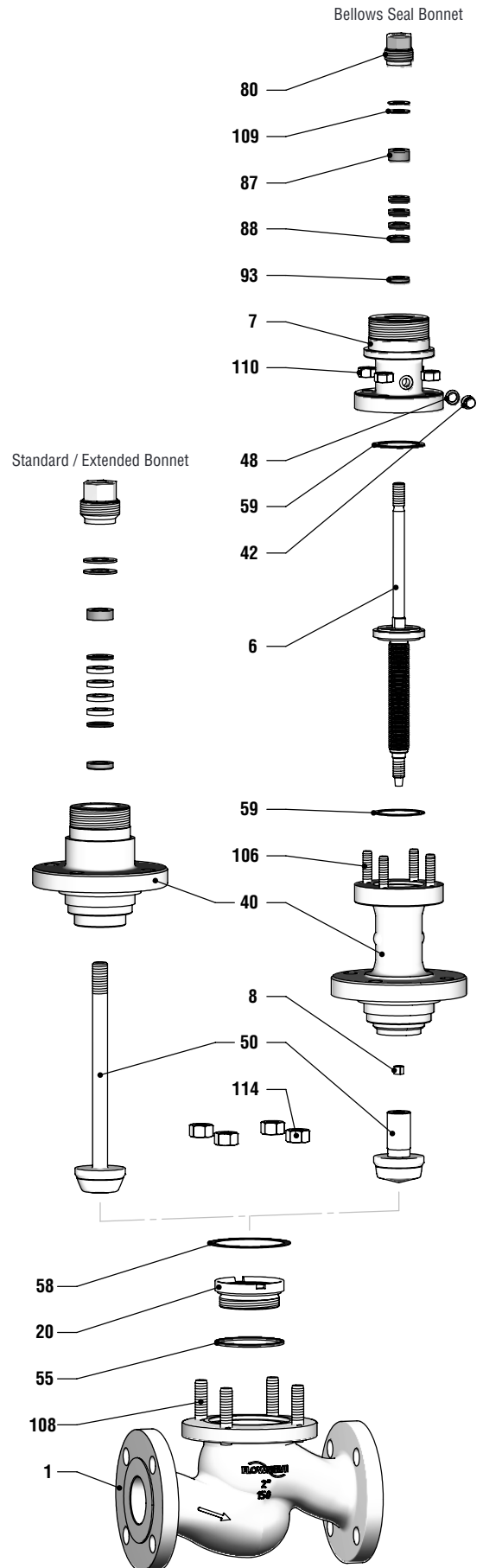

Dimensional Drawing

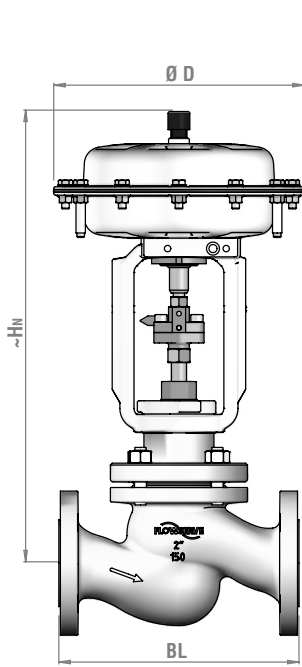

Valve with Standard Bonnet and Pneumatic Actuator

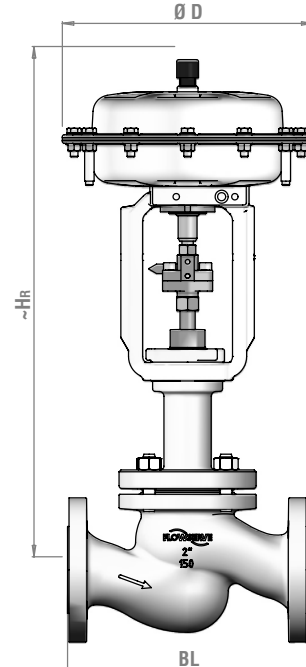

Valve with Extension Bonnet and Pneumatic Actuator

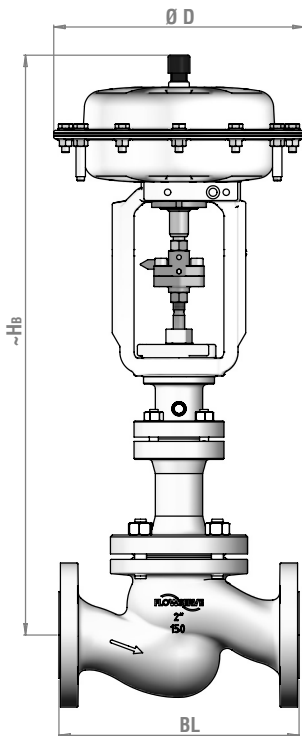

Valve with Bellows Seal Bonnet and Pneumatic Actuator

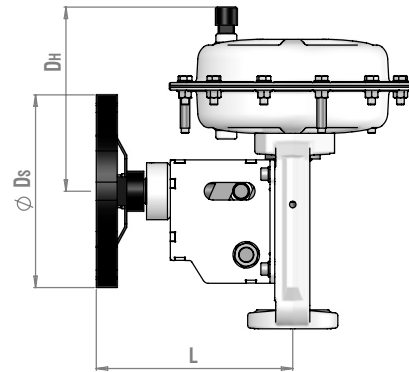

Actuator with side-mounted Handwheel

Size	Ø Ds		L		Dh		+ Weight	
	mm	inch	mm	inch	mm	inch	kg	lbs
IG 253	200	7.87	250	9.84	160	6.30	5,5	12.1
IG 503	350	13.78	550	21.65	200	7.87	18	39.7
IG 701					230	9.06		

Dimensions and Weights

Description			Nominal Size												
			Actuator		15	20	25	32	40	50	65	80	100	125	150
DIN - Valves (mm resp. kg)			Size	Ø D	Stroke 20 mm / 0.787 in.						40 mm / 1.574 in.		60 mm / 2.362 in.		
BL Face to Face Dimension according to EN 558					130	150	160	180	200	230	290	310	350	400	480
~ H _N for Standard Bonnet and Actuator (mm)	IG 253	265	445	445	445	475	475	480							
	IG 503	352	565	565	565	600	600	600	665	665	670				
	IG 701	390				640	640	640	710	710	710	805	805		
~ H _B for Bellows Seal Bonnet and Actuator (mm)	IG 253	265	610	610	610	615	615	615							
	IG 503	352	730	730	730	735	735	735	925	925	925				
	IG 701	390				775	775	775	965	965	965	1230	1235		
~ H _R for Extension Bonnet and Actuator (mm)	IG 253	265	520	520	520	540	540	540							
	IG 503	352	640	640	640	660	660	660	750	750	750				
	IG 701	390				700	700	700	790	790	790	935	940		
~ Weight in kg for Standard Bonnet and Actuator	IG 253		16,5	17,5	18,0	23	24	29							
	IG 503		27	28	28	33	34	39	55	59	75				
	IG 701					44	45	50	66	70	86	109	141		
~ Weight in kg for Bellows Seal Bonnet and Actuator	IG 253		20	21	21	25	26	30							
	IG 503		30	31	31	35	36	40	61	63	78				
	IG 701					46	47	51	72	74	89	125	156		
~ Weight in kg for Extension Bonnet and Actuator	IG 253		17,5	18,0	19,0	24	25	30							
	IG 503		28	28	29	34	35	40	57	61	75				
	IG 701					45	46	51	68	72	86	112	145		
Flanges drilled and dimensioned according to			EN 1092-1, Form B1												
ASME - Valves (mm resp. kg)			Actuator		1/2"	3/4"	1"	-	1 1/2"	2"	-	3"	4"	-	6"
			Size	Ø D	Stroke 20 mm / 0.787 in.						40 mm / 1.574 in.		60 mm / 2.362 in.		
BL Face to Face Dimension acc. to ASME/ISA 75.08.01			Class 150 RF		184	184	184	-	222	254	-	298	352	-	451
			Class 300 RF		190	194	197	-	235	267	-	318	368	-	473
~ H _N , H _B , H _R for Bonnets and Actuators			see DIN - Valves												
~ Weight in kg for Standard Bonnet and Actuator	IG 253		17,0	18,0	19,0	-	29	32							
	IG 503		27	28	29	-	39	42	-	69	94				
	IG 701					-	50	53	-	80	105	-	165		
~ Weight in kg for Bellows Seal Bonnet and Actuator	IG 253		20	22	22	-	30	33							
	IG 503		30	32	32	-	40	43	-	74	96				
	IG 701					-	51	54	-	85	107	-	180		
~ Weight in kg for Extension Bonnet and Actuator	IG 253		18,0	19,0	20	-	29	32							
	IG 503		28	29	30	-	40	43	-	71	95				
	IG 701					-	50	53	-	82	106	-	171		
Flanges drilled and dimensioned according to			ASME B16.5, Raised Face												
BL Face to Face Dimension acc. to ASME/ISA 75.08.01 (inch)			Class 150 RF		7.25	7.25	7.25	-	8.75	10.00	-	11.75	13.88	-	17.75
			Class 300 RF		7.50	7.62	7.75	-	9.25	10.50	-	12.50	14.50	-	18.62
~ H _N for Standard Bonnet and Actuator (inch)	IG 253	10.4	17.5	17.5	17.5	-	18.7	18.9							
	IG 503	13.9	22.2	22.2	22.2	-	23.6	23.6	-	26.2	26.4				
	IG 701	15.4				-	25.2	25.2	-	28.0	28.0	-	31.7		
~ H _B for Bellows Seal Bonnet and Actuator (inch)	IG 253	10.4	24.0	24.0	24.0	-	24.2	24.2							
	IG 503	13.9	28.7	28.7	28.7	-	28.9	28.9	-	36.4	36.4				
	IG 701	15.4				-	30.5	30.5	-	38.0	38.0	-	48.6		
~ H _R for Extension Bonnet and Actuator (inch)	IG 253	10.4	20.5	20.5	20.5	-	21.3	21.3							
	IG 503	13.9	25.2	25.2	25.2	-	26.0	26.0	-	29.5	29.5				
	IG 701	15.4				-	27.6	27.6	-	31.1	31.1	-	37.0		
~ Weight in lbs for Standard Bonnet and Actuator	IG 253		37.5	39.7	41.9	-	63.9	70.5							
	IG 503		59.5	61.7	63.9	-	86.0	92.6	-	152	207				
	IG 701					-	110	117	-	176	231	-	363		
~ Weight in lbs for Bellows Seal Bonnet and Actuator	IG 253		44.1	48.5	48.5	-	66.1	72.8							
	IG 503		66.1	70.5	70.5	-	88.2	94.8	-	163	212				
	IG 701					-	112	120	-	187	235	-	396		
~ Weight in lbs for Extension Bonnet and Actuator	IG 253		39.7	41.9	44.1	-	63.9	70.5							
	IG 503		61.7	63.9	66.1	-	88.2	94.8	-	157	209				
	IG 701					-	110	117	-	180	233	-	376		

General Service Control Valve - GS order code

Valtek GS		Type						Size	PN	Body material / Certificate				Plug				Seat	kvs	Trim						
		V701	D	K	V	N	U	50	40	1.0619	O	O	A	O	P	O	N	P	1	G	G	42	40	316 SS		
Body design	globe, flanged end		D																							
Flange connection according to	EN 1092-1	Form B1	K																							
		Form F	Y																							
	ASME B16.5	RF	F																							
Balancing	without			V																						
	V-ring			O																						
	Piston-ring			K																						
Bonnet	Standard bonnet				N																					
	Bellows seal bonnet				B																					
	Extended bonnet				R																					
Stuffing box packing	PTFE standard, TA-Luft					U																				
	Graphite standard, TA-Luft					V																				
Nominal Size	15 - 20 - 25 - 32 - 40 - 50 - 65 - 80 - 100 - 125 - 150							15 - 150																		
	1/2" - 3/4" - 1" - 1 1/2" - 2" - 3" - 4" - 6"							1/2" - 6"																		
Nominal pressure								PN	16																	
									40																	
									150																	
								Class	300																	
Body material								DIN	1.0619																	
									1.4408																	
									A216WCC																	
								ASME	A351CF8M																	
Regulation for material	without								N																	
	PED								O																	
	PED & AD 2000								A																	
Material certificate	without								O																	
		2.2							Z																	
	EN 10204	3.1 with list of certificates (without CMTR)							B																	
		3.1 with copy of certificates (CMTR of body & bonnet & bolting							E																	
Regulation for final test	EN 1349							IEC 534 / FCI 70-2					A													
Final test certificate	without								O																	
		2.2							Z																	
	EN 10204	3.1							B																	
		3.1							A																	
Plug type	Contoured plug	control service													P											
	Quick Open	on - off seervice													T											
Trim equipment	without	additional trim equipment																		O						
	One-stage	for liquid and gas service								MultiStream											D					
Plug and seat design	standard																				N					
	Seat surface - Alloy 6																					D				
	Full contour - Alloy 6																						K			
	Soft seat																							W		
Seat leakage	Class IV	IEC / FCI		Test medium	Water																			P		
					Gas																					D
	Class V	IEC / FCI		Test medium	Water																				S	
					Gas																					F
	Class VI	IEC / FCI		Test medium	Water																					T
					Gas																					
LR A	EN 12 266		Test medium	Water																					A	
				Gas																						
Plug guiding	Double stem guided / Cage guided with pressure balanced design																							1		
Characteristic	Modified equal percentage																								G	
	Linear																								L	
	Quick Open (on - off)																								A	
Flow direction	Flow under the plug																							G		
Seat diameter																								4 - 130		
kvs - value	(m ³ /h)																							0,4 - 355		
cv - value	(gpm)																							0.46 - 410		
Trim material	316 SS																							316 SS		

Pneumatic multi spring actuator - FlowAct order code

FlowAct				Order code								
				I	G	503	B	FY	O	Z	B	
Actuator design	internal air supply			I								
Yoke design	Multi-function yoke for GS only			G								
Actuator size (cm ² / inch ²)	250	38.75	Stroke (mm / inch)	20	0.79	253						
	500	77.50		20, 40	0.79, 1.57	503						
	700	108.50		20, 40, 60	0.79, 1.57, 2.36	701						
Color	white, powder coated							B				
Spring range (bar / psi)	Actuator size		253		503		701					
	Actuator force (N / lbs)		500	112	1 000	225	1 400	315	AD			
			1 250	281	2 500	562	3 500	787	BL			
			2 500	562	5 000	1 124	7 000	1 574	DY			
			3 750	843	7 500	1 686	10 500	2 360	VC			
			3 750	843	7 500	1 686	10 500	2 360	VI			
			5 000	1 124	10 000	2 248	14 000	3 147	FY			
			-	-	-	-	16 100	3 619	TD			
Handwheel	without							O				
	side-mounted							S				
Safety position at air failure	spring to open									A		
	spring to close									Z		
Stroke (mm / inch)	20	0.79									A	
	40	1.57									B	
	60	2.36									C	

¹⁾ Stroke 20, 40 mm / 0.79, 1.57 inch only !
²⁾ Stroke 20 mm / 0.79 inch only !

Electrical linear actuator - PSL order code

PSL Automation				Order code							
				A	G	202	Z	P	O	15	A
Actuator design	Pillar yoke for GS only			A							
Yoke design	Pillar yoke for GS only			G							
Actuator size	PSL 201	Stroke (mm / inch)	20, 40	0.79, 1.57	Actuator force (N / lbs)	1 000	225	201			
	PSL 202 / 202.1		20, 40	0.79, 1.57		2 000	450	202			
	PSL 204		20, 40	0.79, 1.57	4 500	1 012	204				
	PSL 208		20, 40	0.79, 1.57	8 000	1 798	208				
	PSL 210		20, 40	0.79, 1.57	10 000	2 248	210				
	PSL 214		20, 40, 60	0.79, 1.57, 2.36	14 000	3 147	214				
Voltage	AC 220 - 240 V	50 Hz					Z				
	AC 110 - 115 V	50 Hz (not with PSL 202.1)					Y				
	AC 24 V	50 Hz					F				
Transmitter	without							O			
	two additional position switches			2WE				E			
	potentiometer 1000 Ω			PD 210				P			
	tandem - poti 1000 Ω			PD2 210				D			
	transmitter (mA), two-wire			PSPT02				M			
	potentiometer 1000 Ω with two position switches							Q			
	transmitter (mA) with two position switches							N			
Positioner	without							O			
	positioner 0 (4) - 20 mA, standard version			PSAP 2A				M			
Positioning speed (mm / min) (inch / min)	15	0.59	(PSL 201 / 202.1)								15
	27	1.06	(PSL 210 / 214)								27
	30	1.18	(PSL 202 / 204 / 208)								30
Stroke (mm / inch)	20	0.79									A
	40	1.57									B
	60	2.36									C



USA

Flowserve Flow Control Division
1350 N. Mt. Springs Parkway
Springville, UT 84663
USA
Phone: +1 801 489 8611
Fax: +1 801 489 3719

Austria

Flowserve Control Valves GmbH
Kasernengasse 6
9500 Villach
AUSTRIA
Phone: +43 (0) 4242 41181 - 0
Fax: +43 (0) 4242 41181 - 50

France

Flowserve France S.A.S
PB 60 63307 Thiers Cedex
FRANCE
Phone: +33 4738 04266
Fax: +33 4738 01424

India

Flowserve India Controls Pvt Ltd.
Plot # 4, 1A, Road #8 EPIP White-
field Bangalore, Karnataka, 560066
INDIA
Phone: 91 80 40146200
Fax: 91 80 28410286

China

Flowserve Fluid Motion and
Control (Suzhou) Co., Ltd.
No. 35, Baiyu Road,
Suzhou Industrial Park, Suzhou
Jiangsu Province, P.R. 215021
CHINA
Phone: 86 512 6288 8790
Fax: 86 512 6288 8736

Singapore

Flowserve Pte. Ltd.
12 Tuas Avenue 20
Republic of Singapore 638824
SINGAPORE
Phone: +65 6879 8900
Fax: +65 6862 4940

Saudi Arabia

Flowserve Abahsain Flow Control
Co.,
Ltd.
Makkah Road, Phase 4
Plot 10 & 12, 2nd Industrial City
Damman, Kingdom of Saudi Arabia
Phone: +966 3 857 3150 X 243
Fax: +966 3 857 4243

FCD VLENTB0300A4 03/14 Printed in Europe

To find your local Flowserve representative
or for more information about Flowserve Corporation,
visit www.flowserve.com or call USA 1 800 225 6989

Flowserve Corporation has established industry leadership in the design and manufacture of its products. When properly selected, this Flowserve Corporation product is designed to perform its intended function safely during its useful life. However, the purchaser or user of Flowserve Corporation products should be aware that Flowserve Corporation products might be used in numerous applications under a wide variety of industrial service conditions. Although Flowserve Corporation can (and often does) provide general guidelines, it cannot provide specific data and warnings for all possible applications. The purchaser/user must therefore assume the ultimate responsibility for the proper sizing and selection, installation, operation, and maintenance of Flowserve Corporation products. The purchaser/user should read and understand the Installation Operation Maintenance (IOM) instructions included with the product, and train its employees and contractors in the safe use of Flowserve Corporation products in connection with the specific application.

While the information and specifications contained in this literature are believed to be accurate, they are supplied for informative purposes only and should not be considered certified or as a guarantee of satisfactory results by reliance thereon. Nothing contained herein is to be construed as a warranty or guarantee, express or implied, regarding any matter with respect to this product. Because Flowserve Corporation is continually improving and upgrading its product design, the specifications, dimensions and information contained herein are subject to change without notice. Should any question arise concerning these provisions, the purchaser/user should contact Flowserve Corporation at any one of its worldwide operations or offices.

© 2013 Flowserve Control Valves GmbH, Villach, Austria, Europe. Flowserve is a registered trademark of Flowserve Corporation.

Experience In Motion