



Bag what? How do you pack it?



| | |
|--|---|
| Packing what? | Nail box: can be on the machine specifications Size: length 20mm-100mm nails |
| which way Packing | Box, box shape suggestions (L*W*H) 220mm*100mm*60mm |
| Magnetic sorting machine | Iron nails with a length greater than 60mm need to be sorted by magnetic sorting machine (double-sided magnet) |
| Automatic box opening and sealing | Automatic box opening machine and automatic box sealing machine are purchased equipment, it is recommended that customers fold boxes and cover boxes themselves |

Customer requirements introduction

| | |
|---------------------|--|
| Name | Nails Specification range: Length 20mm-100mm nails |
| form of measurement | Weighing + fiber count complement |
| Speed | Single weighing + single feeding 5-6 boxes/min or so |
| Packing way | Packing (single variety multi-quantity packing) |
| Box shape | Customer box shape can be changed to suggest using a tilting bottom carton |
| Packing weight | The machine can be used: 1KG~5KG/ box; |
| Box size | suggest box size (L*W*H) : 220mm* 100mm*60mm |
| Voltage/power | Machines can be manufactured according to the customer's local voltage and power |
| Optional equipment | Automatic box opening machine, automatic box sealing machine (this equipment is purchased equipment, it is recommended to manually fold the box and cover the box) |



Equipment diagram (excluding automatic box opening machine and automatic box sealing machine)

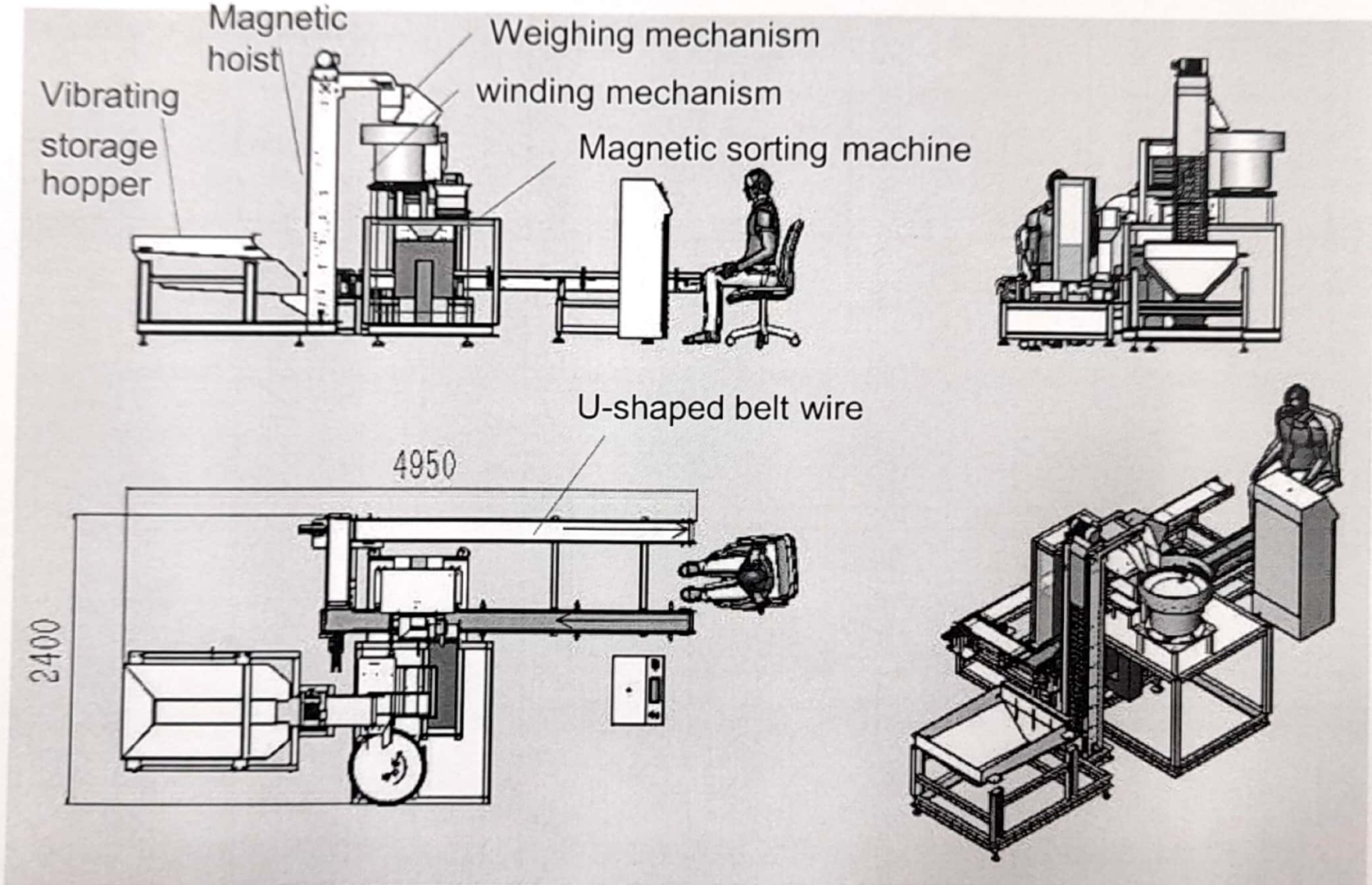

▼ Previous packing machine sample (for reference only)



Feeding vibration disk

Magnetic hoist

vibrating feeder

Electronic control main engine

Boat type bucket elevator

U-shaped conveyor line

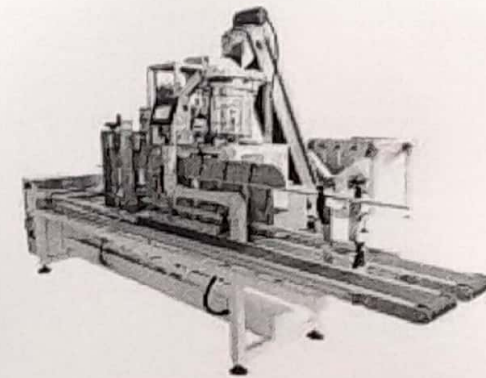
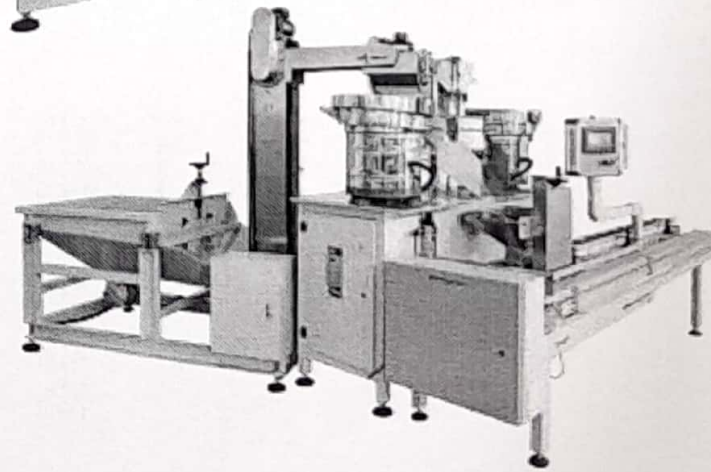
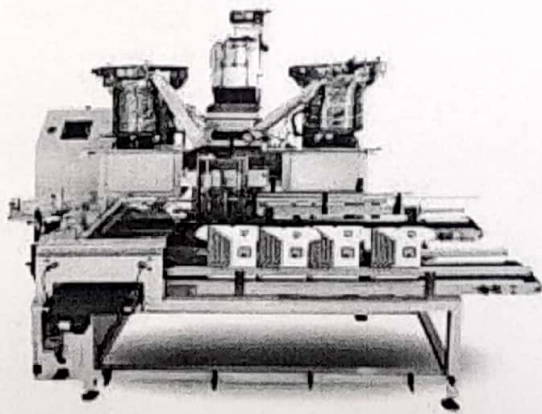
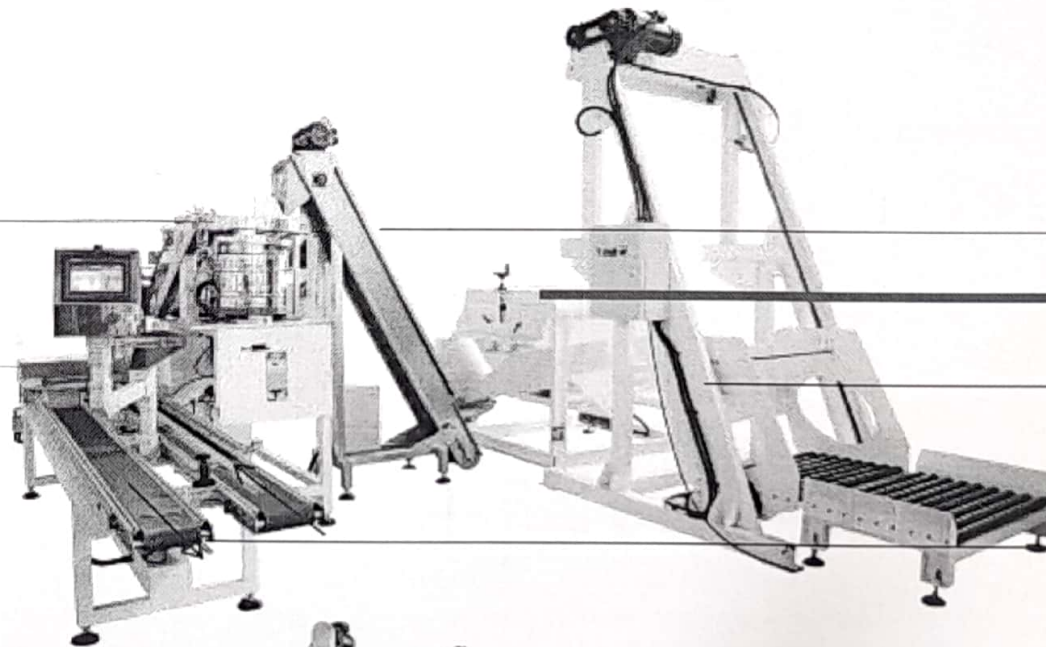



Equipment composition - main control electrical cabinet
and PLC controller



Includes PLC program, man-machine interface
Brand: Delta
Functions: switch, emergency stop, parameter
setting, quantity adjustment, etc.

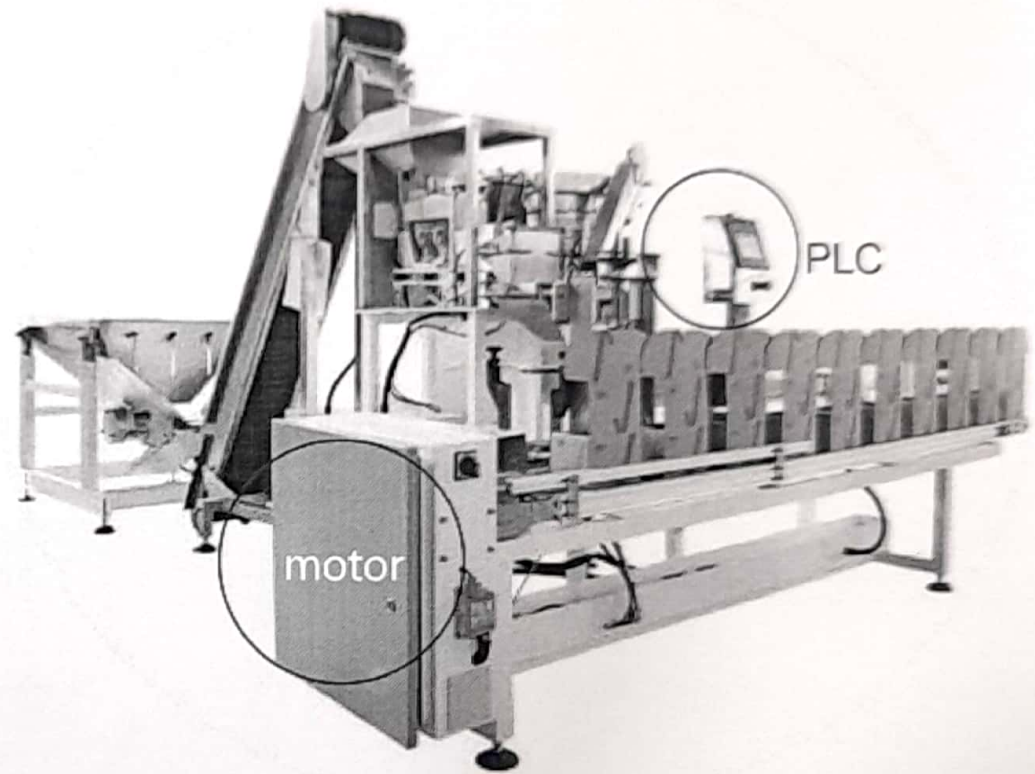

▼ Ship type bucket elevator (optional),
vibration hopper

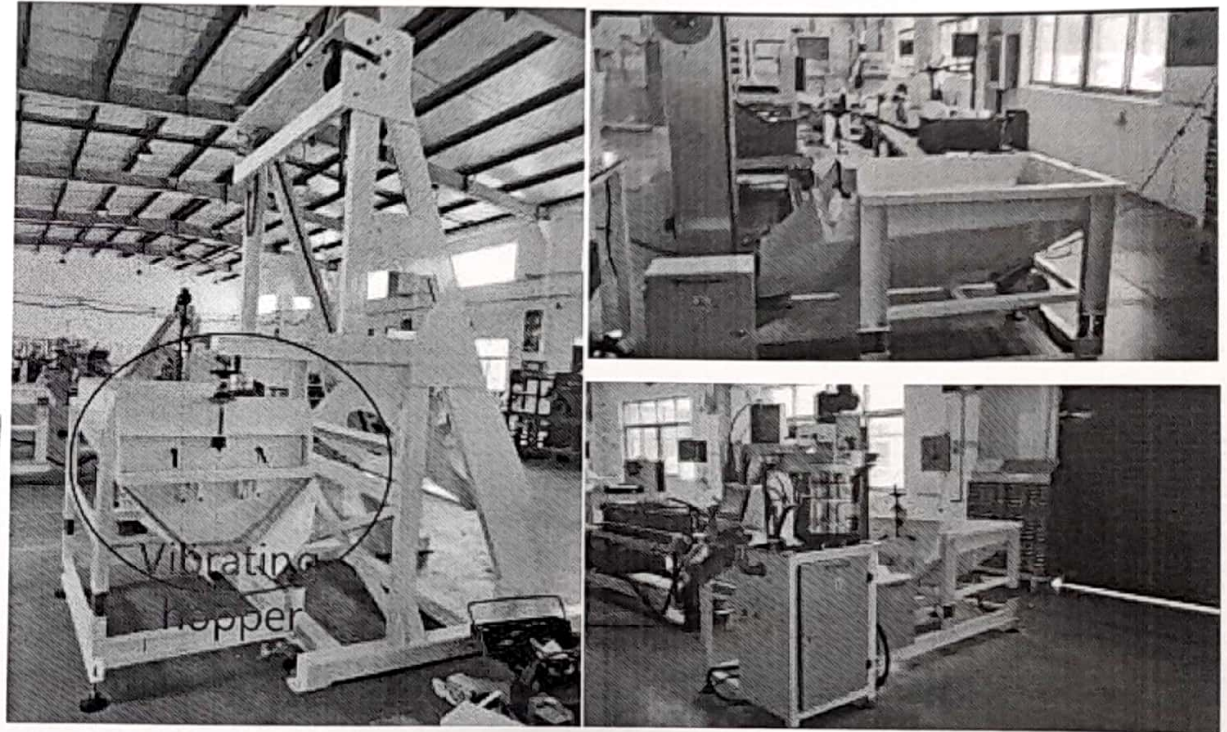
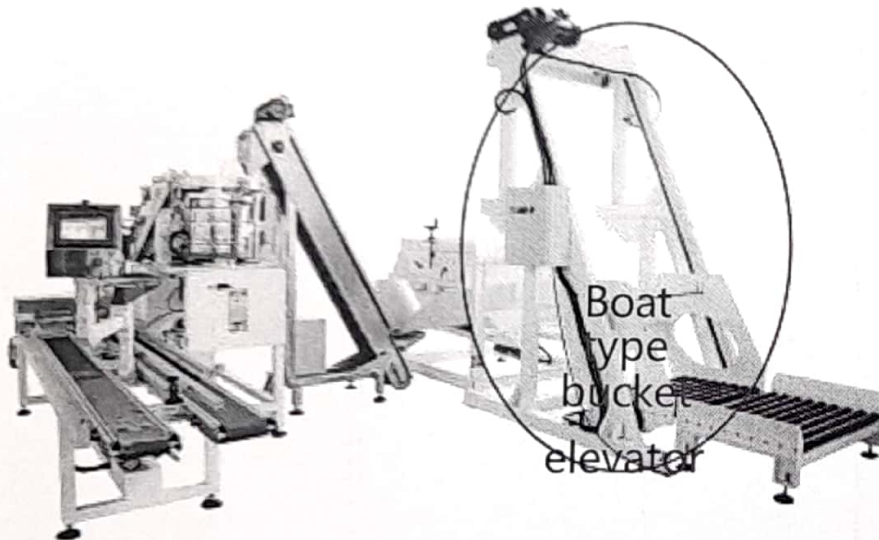

- 1, ship type bucket elevator: optional device to flip the material to lift into the vibration hopper, there is a truss crane can not be used, optional device
- 2, vibration hopper: can hold 300-500KG material

Magnetic hoist, weighing mechanism

Magnetic hoist

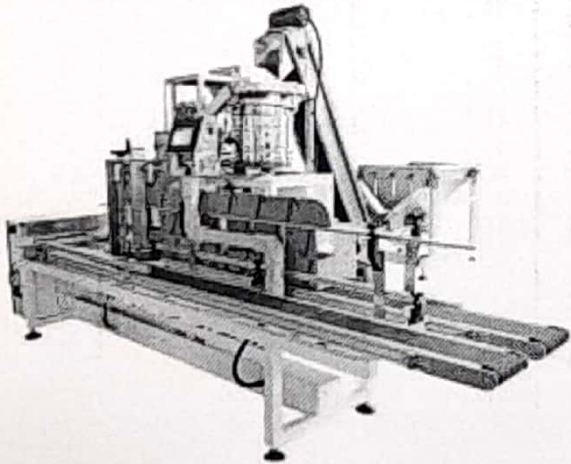
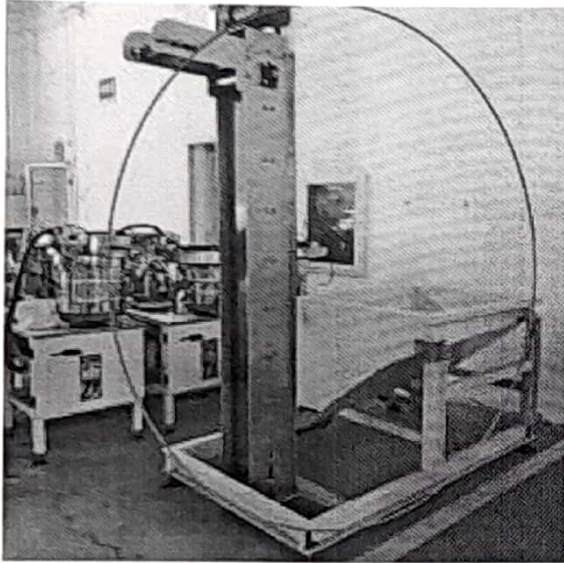

Weighing mechanism

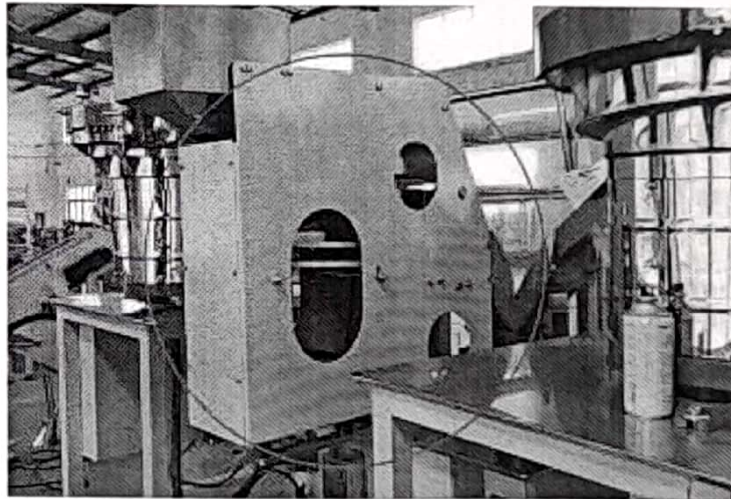

- The weighing system consists of three modules: one vibrating hopper, one magnetic hoist and one weighing box.

- **Operation process:** the direct vibration system (vibration storage hopper) feeds to the magnetic elevator, the magnetic elevator will send the product to the weighing box, when the weighing box is fed to the required amount of 90% to 95%, the elevator stops feeding, measured the exact amount, and the vibrating disk is filled by counting



Device composition - Fiber count complement

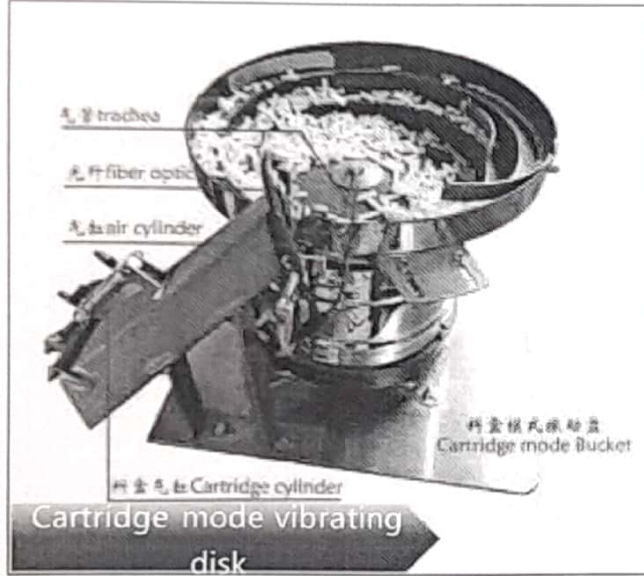

There are two main counting modes of vibration disc, track mode, box mode and belt line mode.
 Track mode: mainly used for screw products; This equipment is equipped with a 620mm screw plate;
 Box mode: mainly used for granular products, such as gaskets, nuts, etc.

counting methods are using optical fiber counting, the use of opTEx brand optical fiber in Japan, can deal with various shapes of materials, and can automatically correct the impact of dust on the brightness value.



Equipment composition - magnetic sorting machine

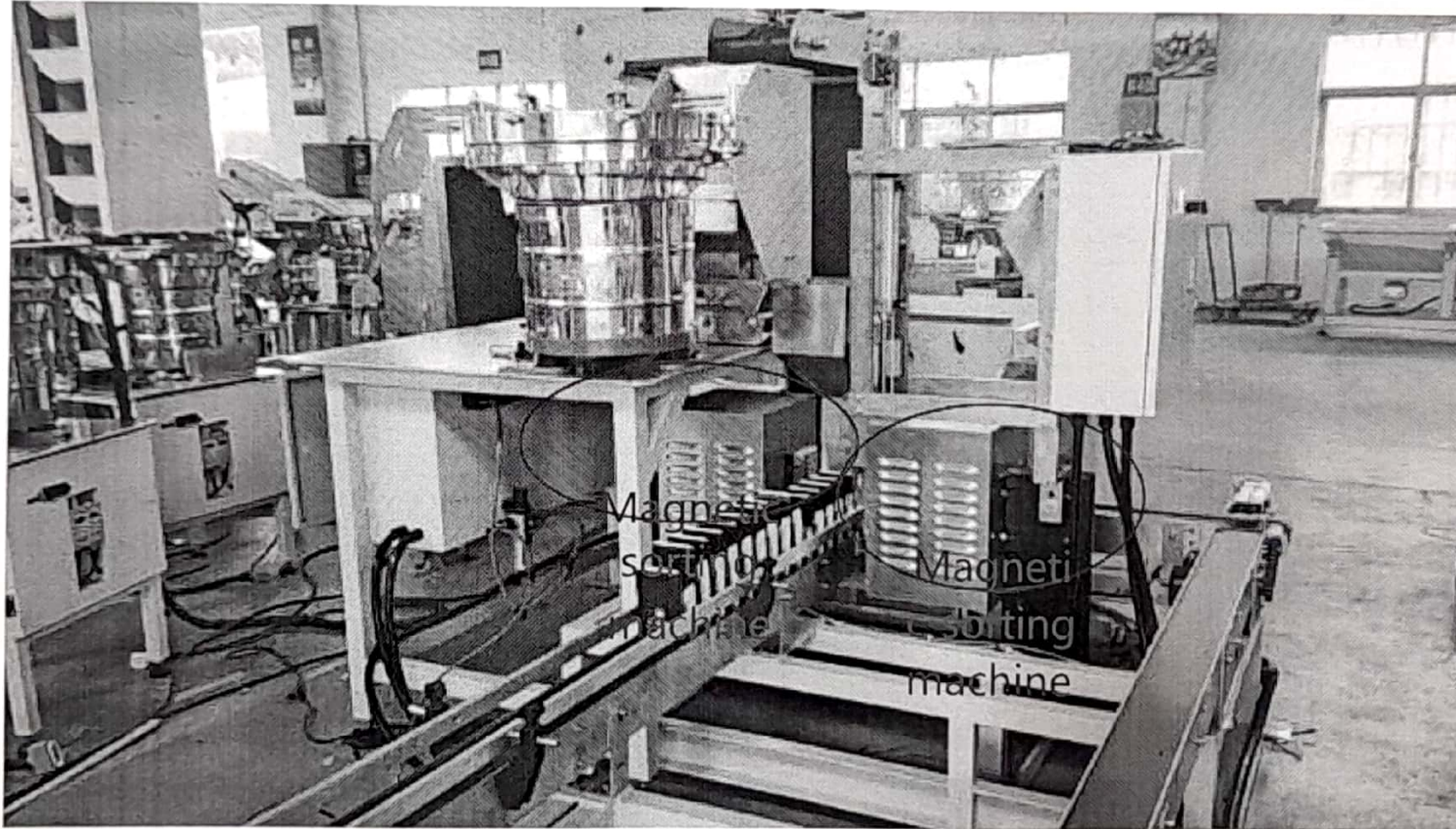

Nails more than 50mm in length need to be sorted, and the sorting effect is about 70%

| Accessories name | Brand |
|------------------------------|-------------------|
| Power switch | Schneider |
| button | Schneider |
| PLC | Delta |
| touch screen | Delta |
| relay | OMRON |
| solid state relay | Delixi |
| air cylinder | AIRTAC |
| Counter cylinder | SMC |
| temperature-controlled meter | SHANGHAI YATAI |
| motor | Taibang/Shengbang |
| bearing | NSK (important) |
| inverter | delta |
| counting sensor | OPTEX |
| pressure sensor | Mettler Toledo |
| connector plug | 豪光 |