

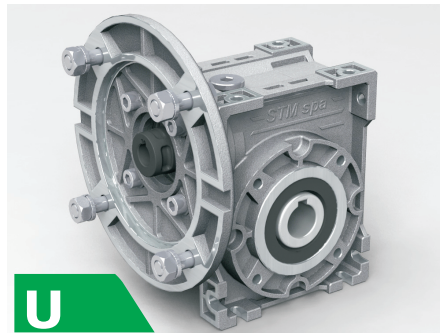

**1.0 RIDUTTORI A VITE SENZA FINE U**  
**1.0 WORM GEARBOXES U**  
**1.0 SCHNECKENGETRIEBE U**

**U**

1.1	Caratteristiche tecniche	<i>Technical characteristics</i>	Technische Eigenschaften	<b>C1</b>
1.2	Designazione	<i>Designation</i>	Bezeichnungen	<b>C3</b>
1.2	Versioni	<i>Versions</i>	Ausführungen	<b>C3</b>
1.4	Lubrificazione	<i>Lubrication</i>	Schmierung	<b>C7</b>
1.5	Carichi radiali e assiali	<i>Axial and overhung loads</i>	Radiale und Axiale Belastungen	<b>C8</b>
1.6	Prestazioni riduttori	<i>Gearboxes performances</i>	Leistungen der Getriebe	<b>C10</b>
1.7	Prestazioni motoriduttori	<i>Gearmotors performances</i>	Leistungen der Getriebemotoren	<b>C12</b>
1.8	Dimensioni	<i>Dimensions</i>	Abmessungen	<b>C18</b>
1.9	Accessori	<i>Accessories</i>	Zubehör	<b>C20</b>



**1.1 Caratteristiche tecniche**

STM presenta un nuovo riduttore di moderna concezione a forma cubica. Questa forma del riduttore permette universalità di fissaggio e modularità estrema per lo stoccaggio del prodotto finito: con l'adozione di un giunto d'accoppiamento al quale possono essere accoppiati tutti i motori Brushless e IEC si garantisce così un'ulteriore versatilità delle configurazioni possibili e l'eliminazione del fenomeno di fretting. La carcassa è disegnata in modo da ottimizzare lo smaltimento del calore e semplificare le operazioni di pulizia, anche negli ambienti più ostili.

**1.1 Technical characteristics**

STM introduces a new range of cube-shaped worm gearboxes. This execution is suitable for a wide variety of fixing possibilities and allows a better modularity of the components in stock. In fact, through an input coupling it is possible to connect all sizes IEC and brushless electric motors and enable a wide range of possible gearbox configurations as well as improving the overall quality by eliminating the fretting. The body has been designed in order to optimize the heat dissipation and to simplify the cleaning of it, even in the most difficult environmental conditions.

**1.1 Technische Eigenschaften**

STM stellt ein neues modern gestaltetes Getriebe in kubischer Form vor. Diese Getriebeform bietet universelle Befestigungsmöglichkeiten und ist äußerst anpassungsfähig bei der Lagerung des Endproduktes: durch die Verwendung einer Kupplung, an die alle bürstenlosen Motoren und IEC angeschlossen werden können, wird die Vielseitigkeit der möglichen Konfigurationen erhöht und die Beseitigung des Phänomens „Fressen“ sichergestellt. Das Gehäuse ist so konzipiert, dass die Wärmeableitung optimiert ist und die Reinigungsarbeiten vereinfacht werden, und dies auch unter schwierigsten Bedingungen.





### 1.1 Caratteristiche tecniche

#### Caratteristiche giunto STM

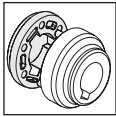

- Ingombri **Ridotti**;
- Semplicità di connessione;
- **NO** Fretting;
- **NO** Vibrazioni;
- Progettato per garantire efficienza e affidabilità con servizi gravosi in presenza di urti e con numerosi avviamenti.

### 1.1 Technical characteristics

#### STM Special features - Coupling

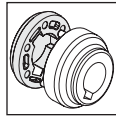

- **Reduced Sizes**
- **Simplified connections**
- **No fretting**
- **No vibrations**
- *Designed in order to warrant efficiency and reliability with heavy duty in case of bumps and frequent start-ups*

### 1.1 Technische Eigenschaften

#### Die STM Sondermerkmale - Kupplung:

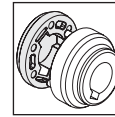

- Verringerter Platzbedarf;
- Einfacher Anschluss;
- Keine Abnutzung;
- Keine Vibrationen;
- Gewährleistet Effizienz und Zuverlässigkeit bei hoher Belastung, Stossbeeinträchtigung und zahlreichen Maschinen-Starts.

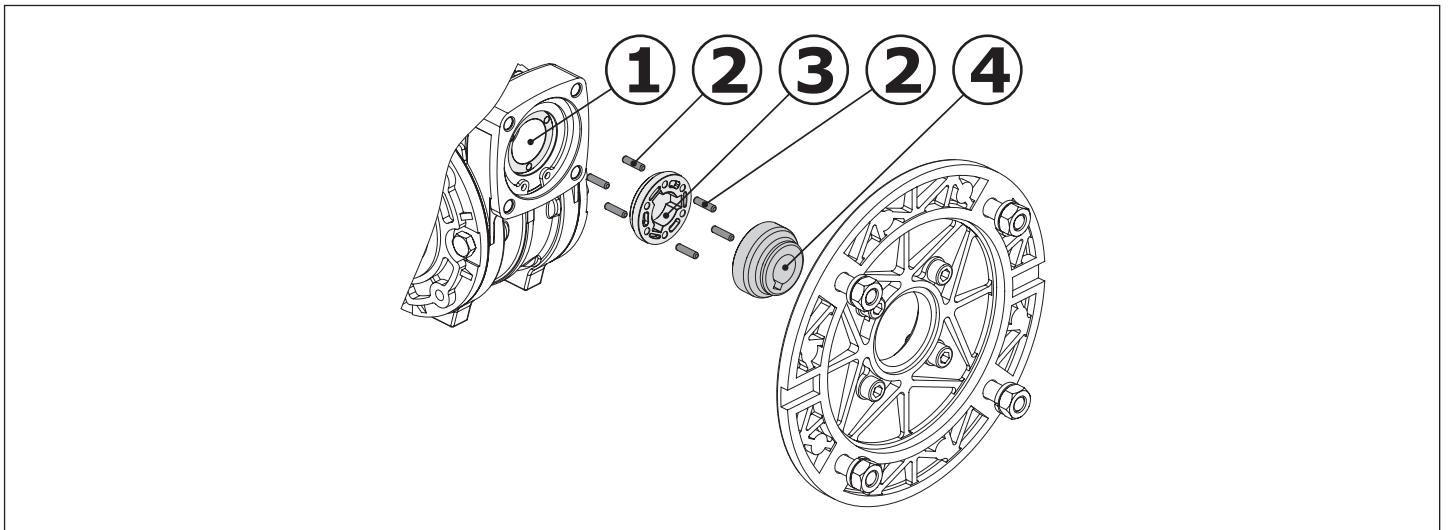

#### MATERIALE:

- 1 - Vite senza fine  
Acciaio Cementazione;
- 2 - Pioli - - Acciaio per cuscinetti
- 3 - Giunto - Tecnopolimero PA 46
- 4 - Semigiunto - Acciaio da bonifica.

#### MATERIAL:

- 1 - Worm gear – cementation steel
- 2 – Pin – bearing steel
- 3 - Coupling – techno polymer PA 46
- 4 – Coupling half - tempered steel

#### MATERIAL:

- 1 – Schneckenwelle - Einsatzstahl
- 2 – Stifte – Lagerstahl
- 3 – Kupplung – Technopolymer PA 46
- 4 – Kupplungshälfte – Stahl wärmebehandelt

#### MANUTENZIONE:

- Facilità di Montaggio motore;
- Facilità di Smontaggio

#### MAINTENANCE:

- Easy motor assembly;
- Easy disassembly.

#### WARTUNG:

- Einfacher Motoreinbau;
- Einfacher Ausbau.

#### MODULARITA':

- Possibilità di utilizzare il giunto sulle serie "RMI" - "CRMI".

#### MODULARITY:

- Possibility of coupling's using specially those of "RMI" - "CRMI" series.*

#### MODULARITÄT

- Die Kupplung kann in den Serien „RMI“ - „CRMI...G“ verwendet werden.

#### TEMPI DI CONSEGNA:

- Maggiore modularità del prodotto;
- Stock a magazzino del prodotto assemblato.

#### DELIVERY DATES

- Higher product's modularity
- Stock warehouse finished product.

#### LIEFERZEITEN:

- Größere Modularität des Produktes;
- Montiertes Produkt im Lagerbestand





## 1.2 Designazione

## 1.2 Designation

## 1.2 Bezeichnung

### 04 IR- Rapporto di riduzione

### IR - Reduction ratio

### IR - Übersetzungsverhältnis

(Vedi prestazioni). Tutti i valori dei rapporti sono approssimati. Per applicazioni dove necessita il valore esatto consultare il ns. servizio tecnico.

(See ratings). Ratios are approximate values. If you need exact values for a specific application, please contact our Engineering.

(Siehe "Leistungen"). Bei allen Werten der Übersetzungen handelt es sich um approximative Wertangaben. Bei Applikationen, bei denen die exakte Wertangabe erforderlich ist, muss unser Technischer Kundendienst konsultiert werden.

05 06 07	<b>UMI</b>	IECT - Tipo IEC e Albero Entrata	IECT - IEC type and Input Shaft	OV - IEC Typ und Antriebswelle
		IV - Versione Entrata	IV - Input Version	IV - Antriebsausführung
		IS - Albero Entrata	IS - Input shaft	IS - Antriebswelle

Possibili accoppiamenti con motori IEC - Possible couplings with IEC motors - Mögliche Verbindungen mit IEC-Motoren															
	IECT	IV	IS	ir - (Rapporto di riduzione / Reduction ratio / Übersetzungsverhältnis)											
				5	7	10	15	20	28	40	49	56	70	80	100
40	G	—	71	14/160 (B5) - 14/105 (B14) - 14/140 - 14/120 - 14/90•											
			63	11/140 (B5) - 11/90• (B14) - 11/160 - 11/120 - 11/105											
			56	9/120 (B5) - 9/160 - 9/140 - 9/105 - 9/90•											
50	G	—	80	19/120 (B14) - 19/200 (B5) - 19/160 - 19/140 - 19/105• - 19/90•											
			71	14/160 (B5) - 14/105• (B14) - 14/200 - 14/140 - 14/120 - 14/90•											
			63	11/140 (B5) - 11/90• (B14) - 11/200 - 11/160 - 11/120 - 11/105•											
63	G	—	90	24/200 (B5) - 24/140 (B14) - 24/160 - 24/120 - 24/105•											
			80	19/200 (B5) - 19/120 (B14) - 19/160 - 19/140 - 19/105•											
			71	14/160 (B5) - 14/105• (B14) - 14/200 - 14/140 - 14/120											
75	G	—	112 <sup>(1)</sup>	—	28/250 (B5) - 28/160 (B14) 28/140										
			100 <sup>(1)</sup>	—	28/250 (B5) - 28/160 (B14) 28/140										
			90	—	24/200 (B5) - 24/140 (B14) - 24/250 - 24/160 - 24/120•										
			80	—	19/200 (B5) - 19/120 (B14)• - 19/250 - 19/160 - 19/140										
90	G	—	112 <sup>(1)</sup>	—	28/250 (B5) - 28/160 (B14)										
			100 <sup>(1)</sup>	—	28/250 (B5) - 28/160 (B14)										
			90	—	24/200 (B5) - 24/140 (B14) - 24/250 - 24/160 - 24/120										
			80	—	19/200 (B5) - 19/120 (B14) - 19/250 - 19/160 - 19/140										
110	G	—	132 <sup>(1)</sup>	—	38/300 (B5) - 38/250 - 38/160										
			112	—	28/250 (B5) - 28/160 (B14) - 28/200 - 28/300										
			100	—	28/250 (B5) - 28/160 (B14) - 28/200 - 28/300										
			90	—	24/200 (B5) - 24/250 - 24/160 - 24/300										

<sup>(1)</sup>ATTENZIONE!  
(Vedere Paragrafo 1.12).

<sup>(1)</sup>WARNING!  
(Look at chapter 1.12).

<sup>(1)</sup>ACHTUNG!  
(s. S. 1.12).

Nella tab. sono riportate le grandezze motore accoppiabili (IEC) unitamente alle dimensioni albero/flangia motore standard

Legenda:

11/140 (B5): combinazioni albero/flangia standard

11/120 : combinazioni albero/flangia a richiesta

In table the possible shaft/flange dimensions IEC standard are listed.

Key:

11/140 : standard shaft/flange combination

11/120 : shaft/flange combinations upon request

In Tabelle sind die möglichen Welle/Flansch- Abmessungen IEC-Standard aufgelistet.

Legende:

11/140 : Standardkombinationen Welle/Flansch

11/120 : Sonderkombinationen Welle/Flansch



1.2 Designazione

1.2 Designation

1.2 Bezeichnung

<b>IECT</b>	<b>G</b>	Accoppiamento con Giunto / <i>Direct with coupling</i> / Direkte mit Kupplung
<b>IV</b>	—	Predisposto per accoppiamento con Unità Motrice IEC / <i>pre arrangement motor IEC</i> / geeignet für die Kombination mit Antriebseinheit IEC
	<b>N</b>	A richiesta / on Request / Auf Anfrage Predisposto per accoppiamento con Unità Motrice NEMA/ <i>pre arrangement motor NEMA</i> / geeignet für die Kombination mit Antriebseinheit NEMA - <b>CT 36 US GB</b>
<b>IS</b>	...	Grandezza IEC / <i>Size IEC</i> /



**Posizione morsetti - Vedere - 19 - PMT - Pagina C6**  
**Terminal board position - Look - 19 - PMT - Page C6**  
**Legende des Klemmenkastens - Siehe - 19 - PMT - Auf Seite C6**

Designazione motore elettrico Se è richiesto un motoriduttore completo di motore è necessario riportare la designazione di quest'ultimo. A tale proposito consultare il ns. catalogo dei motori elettrici Electronic Line.	<i>Electric motor designation</i> For applications requiring a gearmotor, motor designation must be specified. To this end, please refer to our Electronic Line electric motor catalogue.	Bezeichnung des Elektromotors Wird ein Getriebemotor komplett mit Elektromotor angefordert, müssen dessen Daten angegeben werden. Diesbezüglich verweisen wir auf unseren Katalog der Elektromotoren "Electronic Line".
---	--	---

05 06 07	<b>UI</b>	<b>IECT - Tipo IEC e Albero Entrata</b>	<b>IECT - IEC type and Input Shaft</b>	<b>OV - IEC Typ und Antriebswelle</b>
		<b>IV - Versione Entrata</b>	<b>IV - Input Version</b>	<b>IV - Antriebsausführung</b>
		<b>IS - Albero Entrata</b>	<b>IS - Input shaft</b>	<b>IS - Antriebswelle</b>

— Nessuna indicazione = diametro standard;      — No indications = standard diameter;      — Keine Angabe = Standard-durchmesser

<b>UI</b>		<b>40</b>	<b>50</b>	<b>63</b>	<b>75</b>	<b>90</b>	<b>110</b>
		(Ø 11)	(Ø 14)	(Ø 18)	(Ø 24)	(Ø 24)	(Ø 28)

**14 TYPSPD - Tipo Albero uscita**

**TYPSPD - Typ output shaft**

**TYPSPD - Typ Abtriebswelle**

— Nessuna indicazione = le dimensioni dell' albero sono secondo il sistema di misura SI (mm);

— *No indications = The shaft dimensions are subject to the system of units SI (mm).*

— Keine Angabe = Die Wellendimensionen unterliegen dem Einheitensystem SI (mm)

**US** = a richiesta  
è possibile richiedere alberi con le dimensioni secondo il sistema di misura US (inch).  
**CT 36 US GB**

**US** = On request  
It's possible to request shafts dimensions according US measurement system (inch).  
**CT 36 US GB**

**US** = Auf Anfrage  
es ist möglich Wellen anzufordern, die den amerikanischen Abmessungen (inch) entsprechen.  
**CT 36 US GB**

**15 SD - Diametro Albero**

**SD - Shaft diameter**

**SD - Durchmesser Abtriebswelle**



**Diametro albero:**  
— Nessuna indicazione = diametro foro standard.

**Shaft Diameter:**  
— No indications = standard hole diameter.

**Wellendurchmesser:**  
— Keine Angabe = Standard-Bohrungsdurchmesser.

<b>UI - UMI</b>	<b>40</b>	<b>50</b>	<b>63</b>	<b>75</b>	<b>90</b>	<b>110</b>
<b>Standard (mm)</b>	18	25	25	28 (30)	35	42



## 1.2 Designazione

### 16 MPOF - Lato Flangia Uscita

— Nessuna indicazione = flangia uscita con montaggio destro (flange dal lato come indicato nelle figure);

**SIN** = flange uscita con montaggio sinistro (flange dal lato opposto alle figure indicate).

## 1.2 Designation

### MPOF - Mounting Position Output

— No indication (standard) = output flange on right side (like indicated in the figures);

**SIN** = output flange on left side (flanges on the opposite side like indicated in figures).

## 1.2 Bezeichnung

### MPOF - Montageseite Abtriebsflansch

— Keine Angabe (Standard) = Abtriebsflansch rechts (wie in den Abbildungen dargestellt)

**SIN** = Abtriebsflansch links (gegenüber der Position in den Katalogabbildungen).

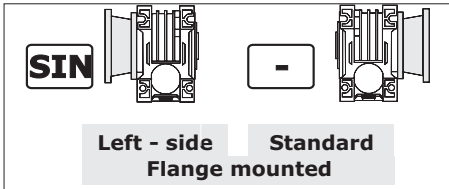

### 17 MP - Posizioni di montaggio

[M2, M3, M4, M5, M6] Posizioni di montaggio con indicazione dei tappi di livello, carico e scarico; se non specificato si considera standard la posizione **M1** (vedi par. 1.4)

### MP - Mounting positions

[M2, M3, M4, M5, M6] Mounting position with indication of breather level and drain plugs; if not specified, standard position is **M1** (see par. 1.4).

### MP - Einbaulagen

Montageposition [M2, M3, M4, M5, M6] mit Angabe von . Entlüftung, Schaugläsern und Ablassschraube. Wenn nicht näher spezifiziert, wird die Standard - position **M1** zugrunde gelegt (s. Abschnitt 1.4).

### 18 OPT-ACC. - Opzioni

### OPT-ACC - Options

### OPT-ACC. - Optionen

vedi par. 1.9 see pa. 1.9 s. Abschnitt 1.9	ACC1	AL	Alberi lenti - AL	Output shafts - AL	Abtriebswellen - AL
		AL_BU	Alberi lenti Bisporgenti - AL_BU	Double Output shafts - AL_BU	Beidseitige Abtriebswellen - AL_BU
		PROT.	Coperchio di protezione	Protection cover	Schutzvorrichtungdeckel
	ACC3	BRS_VKL	Braccio Reazione Semplice_con boccola_VKL	Torque arm - Single_with VKL_bushing	Drehmomentstütze - Normal_mit VKL - Buchse
	ACC9	ELSX	Vite senza fine - Elica Sinistra	Worm Geraboxe - Left helix	Linksgängige Schraubenlinie der Schneke
vedi Sezione A-1.12 see Section A-1.12 s. Abschnitt A-1.12	OPT.	OPT	Materiale degli anelli di tenuta	Materials of Seals	Dichtungsstoffe
		OPT1	Stato fornitura olio	Scope of the supply - Options - OIL	Optionen - Lieferzustand - Optionen - Öl
		OPT2	Verniciatura	Painting and surface protection	Lackierung und Oberflächenschutzl

### 19 PMT - Posizioni della Morsettieria

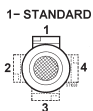

[2, 3, 4] Posizione della morsettieria del motore se diversa da quella standard (1).

**N.B.**

La configurazione standard della flangia at- tacco motore prevede 4 fori a 45°.

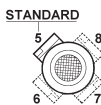

Per le flange contrassegnate con il simbolo (\*) (vedi pagina B10) i fori per il fissaggio al motore sono disposti in croce (esempio +). Pertanto è opportuno valutare l'ingombro della morsettieria del motore che verrà installato in quanto essa verrà a trovarsi orientata a 45° rispetto agli assi. Per la scelta della posizione della morsettieria rispetto agli assi fare riferimento allo schema seguente (in cui la posizione 5 è quella standard):

### PMT - Position Terminal Box

[2, 3, 4] Position of the motor terminal box if different from the standard one (1).

**Note.**

The standard configuration for the 4 holes is 45° to the axes (like an x: see par 2.3).

For the flanges marked with (\*) (see page B10) the holes to fit the motor are on the axes (like a +). Therefore we suggest to check the dimensions of the terminal board of the motor as it will be at 45° to the axes. Please choose the terminal board position referring to the following sketch (in which n° 5 is the standard position):

### PMT - Montagposition Klemmenkasten

Montageposition Klemmenkasten [2, 3, 4], wenn abweichend von Standardposition [1] (für Motortriebe).

**HINWEIS.**

In der Standardkonfiguration sind die 4 Flansch- bohrungen im 45°-Winkel zu den Achsen angeordnet

Bei Flanschen, die mit (\*) (Siehe auf Seite B10) gekennzeichnet sind, sind die Bohrungen auf den Achsen angeordnet (wie ein +). Es sollte deshalb der Platzbedarf des Motorklemmenkastens beachtet werden, da er sich in 45°-Position zu den Achsen befinden wird. Die Lage des Klemmenkastens des Motors wählen Sie bitte anhand der folgenden Skizze (Pos. 5 ist Standardposition):





1.4 Lubrificazione

1.4 Lubrication

1.4 Schmierung



Posizioni di montaggio  
Mounting positions  
Montagepositionen

UI - UMI

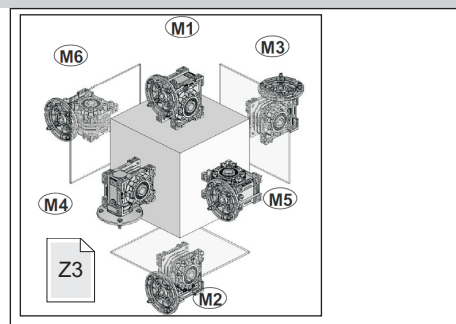
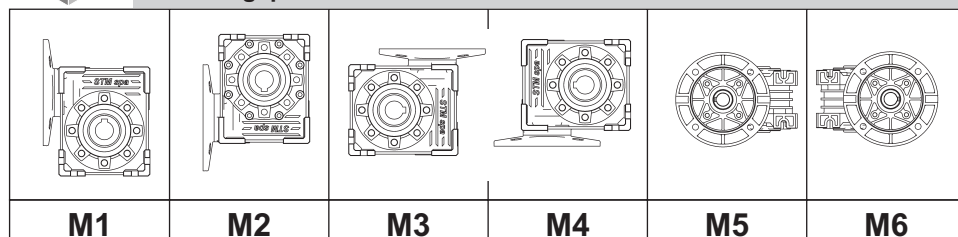

		Posizioni di montaggio - Mounting positions - Montagepositionen	
		Posizioni Positions Positionen	Prescrizioni da indicare in fase d'ordine Ordering requirements Anforderungen bei der Bestellung
UI UMI	40	M1-M2 M3-M4 M5-M6	Non necessaria Not necessary Nicht erforderlich
	50		
	63		
	75		
	90	M1-M2 M3-M4 M5-M6	Necessaria Necessary Erforderlich
	110		

**M3-M4**  
Particolare attenzione va posta per i riduttori montati nelle posizioni M3 e M4 che sono forniti con il cuscinetto schermato.

**M3-M4**  
Particular attention should be paid to worm gearboxes with a shielded bearing mounted in positions M3 and M4.

**M3-M4**  
Besondere Aufmerksamkeit sollte den Getrieben zukommen, die in den Einbaulagen M3 und M4 montiert werden und mit abgeschirmtm Lager geliefert werden.

TARGHETTA - RIDUTTORE

**NON NECESSARIA**  
Indicata sempre nella targhetta del riduttore la posizione di montaggio "M1".

Identification Plate - Gearbox

**NOT NECESSARY**  
The mounting position is always indicated on the nameplate "M1".

Typeschild - Getriebe

**NICHT ERFORDERLICH**  
Die Einbaulage ist immer auf dem Typenschild angegeben "M1".

**NECESSARIA**  
La posizione richiesta è indicata nella targhetta del riduttore

**NECESSARY**  
The indication it on the label of the gearbox

**ERFORDERLICH**  
Findet man die angefragte Position auf dem Typenschild des Getriebe

Lub	Quantità di lubrificante - Lubricant Quantity - Schmiermittelmenge - [Kg]								OPT1	N°	Diameter	Type
		M1	M2	M3	M4	M5	M6					
UI UMI	UI-RMI	40	0.070						INOIL_STD	1	1/4"	
	UI	50	0.170									
	UMI		0.130									
	UI	63	0.350									
	UMI		0.240									
	UI-UMI	75	0.450									
	UI-UMI	90	1.000	0.600								
	UI-UMI	110	1.600	1.300								
								1	3/8"			

**Attentione !:**  
Il tappo di sfiato è allegato solo nei riduttori che hanno più di un tappo olio

**Warning!:**  
A breather plug is supplied only with worm gearboxes that have more than one oil plug

**Achtung!:**  
Der Entlüftungsstopfen ist lediglich bei den Getrieben vorhanden, die über mehr als einen Öfüllstopfen verfügen

**Nota:** Se in fase d'ordine la posizione di montaggio è omessa, il riduttore verrà fornito con i tappi predisposti per la posizione M1.

**Note:** If the mounting position is not specified in the order, the worm gearbox supplied will have plugs pre-arranged for position M1.

**Anmerkung:** Sollte in der Auftragsphase die Einbaulage nicht angegeben werden, wird das Getriebe mit Stopfen für die Einbaulage M1.

Eventuali forniture con predisposizioni tappi diverse da quella indicata in tabella, dovranno essere concordate.

The supply of gearboxes with different plug pre-arrangements has to be agreed with the manufacturer.

Lieferungen, die eine Auslegung hinsichtlich der Stopfen aufweisen, die von den Angaben in der Tabelle abweichen, müssen vorab vereinbart werden..



### 1.5 Carichi radiali e assiali

Quando la trasmissione del moto avviene tramite meccanismi che generano carichi radiali sull'estremità dell'albero, è necessario verificare che i valori risultanti non eccedono quelli indicati nelle tabelle.

Nella Tab. 2.5 sono riportati i valori dei carichi radiali ammissibili per l'albero veloce ( $Fr_1$ ). Come carico assiale ammissibile contemporaneo si ha:

$$Fa_1 = 0.2 \times Fr_1$$

Tab. 2.5



**UI**

$n_1$ min <sup>-1</sup>	$Fr_1$ (N)					
	UI					
	40	50	63	75	90	110
<b>2800</b>	187	272	357	510	700	850
<b>1400</b>	220	320	420	600	800	1000
<b>900</b>	250	350	460	660	900	1200
<b>700</b>	280	400	500	730	1000	1300
<b>500</b>	310	450	530	800	1100	1450

In Tab. 2.7 sono riportati i valori dei carichi radiali ammissibili per l'albero lento ( $Fr_2$ ). Come carico assiale ammissibile contemporaneo si ha:

$$Fa_2 = 0.2 \times Fr_2$$

Tab. 2.7



**UI  
UMI**

$n_2$ min <sup>-1</sup>	$Fr_2$ (N)					
	UI - UMI					
	40	50	63	75	90	110
<b>400</b>	686	925	946	1400	1897	2168
<b>280</b>	808	1088	1114	1700	2232	2550
<b>200</b>	950	1280	1310	2000	2625	3000
<b>140</b>	1050	1450	1680	2300	2775	3150
<b>93</b>	1200	1620	1740	2600	3050	3600
<b>70</b>	1350	1850	1930	2800	3400	4150
<b>50</b>	1500	2100	2150	3400	4205	4850
<b>35</b>	1600	2230	2300	3700	4775	5700
<b>29</b>	1700	2400	2500	4100	5300	6200
<b>25</b>	1800	2580	2700	4300	5610	6600
<b>20</b>	1950	2700	2900	4700	6175	7200
<b>18</b>	2100	2850	3100	4900	6650	7800
<b>14</b>	2300	3200	3300	5200	7025	8250

A richiesta possono essere fornite versioni rinforzate con cuscinetti a rulli conici sulla corona in grado di sopportare carichi superiori a quelli ammessi dalle versioni normali.

Si veda a tal proposito la tabella 2.9, in cui sono riportati i valori dei carichi radiali e assiali ammissibili sull'albero uscita nel caso di cuscinetti conici sulla corona. Si consiglia, in questi casi, di adottare versioni flangiate, verificando che il carico assiale venga interamente assorbito dal cuscinetto alloggiato nella flangia di fissaggio.

### 1.5 Axial and overhung loads

*Should transmission movement determine radial loads on the angular shaft end, it is necessary to make sure that resulting values do not exceed the ones indicated in the tables.*

*In Table 2.5 permissible radial load for input shaft are listed ( $Fr_1$ ). Contemporary permissible axial load is given by the following formula:*

$$Fa_1 = 0.2 \times Fr_1$$

### 1.5 Radiale und Axiale Belastungen

Wird das Wellenende auch durch Radialkräfte belastet, so muß sichergestellt werden, daß die resultierenden Werte die in der Tabelle angegebenen nicht überschreiten.

In Tabelle 2.5 sind die Werte der zulässigen Radialbelastungen für die Antriebswelle ( $Fr_1$ ) angegeben. Die Axialbelastung beträgt dann:

$$Fa_1 = 0.2 \times Fr_1$$

*In Table 2.7 permissible radial loads for output shaft are listed ( $Fr_2$ ). Permissible axial load is given by the following formula:*

$$Fa_2 = 0.2 \times Fr_2$$

In Tabelle 2.7 sind die Werte der zulässigen Radialbelastungen für die Abtriebswelle angegeben.

Als zulässige Axialbelastung gilt:

$$Fa_2 = 0.2 \times Fr_2$$

*In order to increase the load capacity of the gearboxes it is possible to fit taper roller bearings on to the output shaft. Such reinforced versions are available upon request.*

*With regard to this reinforced version, let see output radial and axial load values shown on tab. 2.9. It's advisable to use flange mounted versions and to make sure that the axial load is absorbed by the bearing, housed in the fixing flange.*

Für größere Belastungen stehen auf Wunsch auch verstärkte Ausführungen mit Kegelrollenlagern für die Schneckenwelle zur Verfügung.

Tabelle 2.9 listet die zulässigen Radial- und Axiallasten bei Verwendung von Kegelrollenlagern auf. Es wird in diesen Fällen empfohlen, Flanschausführungen zu verwenden und sicherzustellen, daß die axiale Last vollständig vom Lager, das sich im Befestigungsflansch befindet, aufgenommen wird.





UI  
UMI

Tab. 2.9

CARICHI RADIALI - ASSIALI CON CUSCINETTI CONICI SULLA CORONA AXIAL AND OVERHUNG LOADS WITH TAPER ROLLER BEARINGS ON WORMWHEEL RADIALE UND AXIALE BELASTUNGEN MIT KEGELROLLENLAGERN AUF DEM SCHNECKENRAD												
n <sub>2</sub> (rpm)	UI - UMI											
	40		50		63		75		90		110	
	Fr <sub>2</sub>	Fa <sub>2</sub>	Fr <sub>2</sub>	Fa <sub>2</sub>	Fr <sub>2</sub>	Fa <sub>2</sub>	Fr <sub>2</sub>	Fa <sub>2</sub>	Fr <sub>2</sub>	Fa <sub>2</sub>	Fr <sub>2</sub>	Fa <sub>2</sub>
400	2076	2708	4603	5325	4693	5415	5415	6588	6543	8529	7671	9837
280	2185	2850	4845	5605	4940	5700	5700	6935	6888	8978	8075	10355
200	2300	3000	5100	5900	5200	6000	6000	7300	7250	9450	8500	10900
140	2300	3000	5600	6500	5750	6650	6700	8200	7900	10300	9200	11800
93	2300	3000	6300	7300	6500	7550	7500	9150	8400	10950	9200	11800
70	2300	3000	6550	7600	6200	7200	7600	9300	7850	10225	9200	11800
50	2300	3000	6900	8000	6900	8000	8700	10600	9250	12050	10600	13600
35	2300	3000	6900	8000	6900	8000	9000	11000	11450	14900	13900	13600
29	2300	3000	6900	8000	6900	8000	9000	11000	11900	15500	14800	17800
25	2300	3000	6900	8000	6900	8000	9000	11000	11900	15500	14800	19000
20	2300	3000	6900	8000	6900	8000	9000	11000	11900	15500	14800	19000
18	2300	3000	6900	8000	6900	8000	9000	11000	11900	15500	14800	19000

I carichi radiali indicati nelle tabelle si intendono applicati a metà della sporgenza dell'albero e sono riferiti ai riduttori operanti con fattore di servizio 1.

Valori intermedi relativi a velocità non riportate possono essere ottenuti per interpolazione considerando però che Fr<sub>1</sub> a 500 min<sup>-1</sup> e Fr<sub>2</sub> a 14 min<sup>-1</sup> rappresentano i carichi massimi consentiti.

Per i carichi non agenti sulla mezzeria dell'albero lento o veloce si ha:

*The radial loads shown in the tables are applied on the centre line of the shaft extension and are related to gearboxes working with service factor 1.*

*Intermediate values of speeds that are not listed can be obtained through interpolation but it must be considered that Fr<sub>1</sub> at 500 min<sup>-1</sup> and Fr<sub>2</sub> at 14 min<sup>-1</sup> represent the maximum allowable loads.*

*For loads which are not applied on the centre line of the output or input shaft, following values will be obtained:*

Bei den in der Tabelle angegebenen Radialbelastungen wird eine Kräfteinwirkung auf die Mitte des Wellenendes zugrunde gelegt; außerdem arbeiten die Getriebe mit Betriebsfaktor 1. Zwischenwerte für nicht aufgeführte Drehzahlen können durch Interpolation ermittelt werden. Hierbei ist jedoch zu berücksichtigen, daß die Werte von Fr<sub>1</sub> bei 500 min<sup>-1</sup> und von Fr<sub>2</sub> bei 14 min<sup>-1</sup> die Maximalbelastungen repräsentieren.

Bei Lasten, die nicht auf die Mitte der Ab- bzw. Antriebswellen wirken, legt man folgende Werte zugrunde:

a 0.3 della sporgenza:  
 $Fr_x = 1.25 \times Fr_{1-2}$

a 0.8 dalla sporgenza:  
 $Fr_x = 0.8 \times Fr_{1-2}$

at 0.3 from extension:  
 $Fr_x = 1.25 \times Fr_{1-2}$

at 0.8 from extension:  
 $Fr_x = 0.8 \times Fr_{1-2}$

0.3 vom Wellenabsatz:  
 $Fr_x = 1.25 \times Fr_{1-2}$

0.8 vom Wellenabsatz:  
 $Fr_x = 0.8 \times Fr_{1-2}$

Tab. 2.11

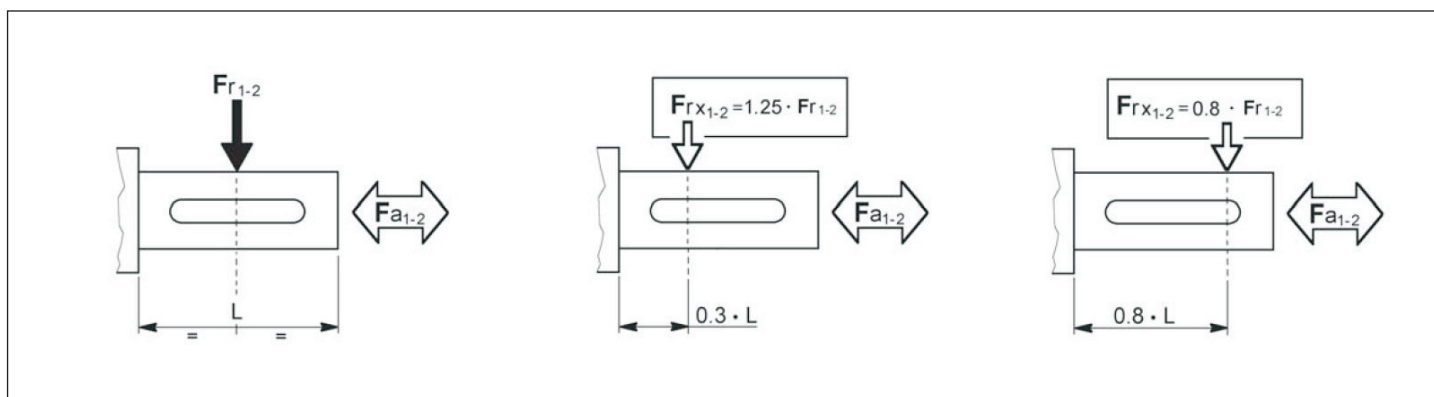



1.6 Prestazioni riduttori UI

1.6 UI Gearboxes performances

1.6 Leistungen der UI-Getriebe

UI 40



2.1

ir	n <sub>1</sub> = 2800 min <sup>-1</sup> ⚠				n <sub>1</sub> = 1400 min <sup>-1</sup>				n <sub>1</sub> = 900 min <sup>-1</sup>				n <sub>1</sub> = 500 min <sup>-1</sup>				IEC
	n <sub>2</sub> min <sup>-1</sup>	T <sub>2M</sub> Nm	P kW	RD %	n <sub>2</sub> min <sup>-1</sup>	T <sub>2M</sub> Nm	P kW	RD %	n <sub>2</sub> min <sup>-1</sup>	T <sub>2M</sub> Nm	P kW	RD %	n <sub>2</sub> min <sup>-1</sup>	T <sub>2M</sub> Nm	P kW	RD %	
5	560	27	1.8	86	280	37	1.28	85	180	44	1.00	83	100	54	0.69	82	71-63-56
7	400	27	1.3	84	200	37	0.93	83	129	44	0.73	81	71	54	0.50	80	
10	280	31	1.1	83	140	42	0.76	81	90	49	0.58	79	50	59	0.40	78	
15	187	32	0.78	80	93	42	0.53	77	60	49	0.41	75	33	59	0.28	73	
20	140	29	0.56	76	70	37	0.37	73	45	43	0.29	70	25	51	0.20	67	
28	100	34	0.50	71	50	43	0.34	67	32	50	0.26	64	17.9	59	0.18	61	
40	70	32	0.36	65	35	40	0.24	60	23	45	0.19	56	12.5	53	0.13	53	
49	57	30	0.29	62	29	38	0.20	57	18.4	43	0.16	53	10.2	50	0.11	49	
56	50	28	0.24	60	25	36	0.17	54	16.1	40	0.13	51	8.9	47	0.09	47	
70	40	23	0.18	53	20	28	0.12	47	12.9	32	0.10	44	7.1	37	0.07	39	
80	35	21	0.15	50	17.5	26	0.11	44	11.3	29	0.09	40	6.3	34	0.06	36	
100	28	23	0.13	51	14.0	28	0.09	45	9.0	30	0.07	41	5.0	31	0.04	38	

UI 50



3.5

ir	n <sub>1</sub> = 2800 min <sup>-1</sup> ⚠				n <sub>1</sub> = 1400 min <sup>-1</sup>				n <sub>1</sub> = 900 min <sup>-1</sup>				n <sub>1</sub> = 500 min <sup>-1</sup>				IEC
	n <sub>2</sub> min <sup>-1</sup>	T <sub>2M</sub> Nm	P kW	RD %	n <sub>2</sub> min <sup>-1</sup>	T <sub>2M</sub> Nm	P kW	RD %	n <sub>2</sub> min <sup>-1</sup>	T <sub>2M</sub> Nm	P kW	RD %	n <sub>2</sub> min <sup>-1</sup>	T <sub>2M</sub> Nm	P kW	RD %	
5	560	45	3.0	87	280	65	2.2	86	180	75	1.7	85	100	95	1.18	84	80-71-63
7	400	50	2.5	85	200	68	1.7	84	129	81	1.3	83	71	100	0.91	82	
10	280	55	1.9	84	140	73	1.3	82	90	86	1.0	81	50	105	0.70	79	
15	187	58	1.4	82	93	76	0.93	80	60	89	0.71	79	33	106	0.48	77	
20	140	57	1.1	79	70	74	0.71	76	45	86	0.55	74	25	102	0.38	71	
28	100	62	0.88	74	50	80	0.60	70	32	92	0.46	67	17.9	109	0.32	64	
40	70	64	0.67	70	35	81	0.45	66	23	92	0.34	63	12.5	108	0.24	59	
49	57	57	0.51	67	29	72	0.34	63	18.4	82	0.27	59	10.2	96	0.19	55	
56	50	55	0.44	65	25	69	0.30	60	16.1	78	0.23	56	8.9	91	0.16	53	
70	40	52	0.36	61	20	64	0.24	56	12.9	72	0.19	52	7.1	84	0.13	48	
80	35	47	0.30	57	17.5	58	0.21	51	11.3	66	0.17	47	6.3	75	0.11	43	
100	28	42	0.23	54	14.0	52	0.16	48	9.0	59	0.13	44	5.0	60	0.08	40	

UI 63



6.0

ir	n <sub>1</sub> = 2800 min <sup>-1</sup> ⚠				n <sub>1</sub> = 1400 min <sup>-1</sup>				n <sub>1</sub> = 900 min <sup>-1</sup>				n <sub>1</sub> = 500 min <sup>-1</sup>				IEC
	n <sub>2</sub> min <sup>-1</sup>	T <sub>2M</sub> Nm	P kW	RD %	n <sub>2</sub> min <sup>-1</sup>	T <sub>2M</sub> Nm	P kW	RD %	n <sub>2</sub> min <sup>-1</sup>	T <sub>2M</sub> Nm	P kW	RD %	n <sub>2</sub> min <sup>-1</sup>	T <sub>2M</sub> Nm	P kW	RD %	
5	560	79	5.3	88	280	110	3.8	86	180	132	2.9	86	100	164	2.0	85	90-80-71
7	400	84	4.1	86	200	115	2.9	84	129	137	2.2	84	71	169	1.5	83	
10	280	93	3.2	84	140	126	2.2	83	90	149	1.7	81	50	182	1.2	80	
15	187	98	2.3	82	93	131	1.6	80	60	153	1.2	78	33	184	0.85	76	
20	140	104	1.9	80	70	136	1.3	77	45	158	0.99	75	25	189	0.69	72	
28	100	105	1.5	75	50	135	1.0	71	32	156	0.77	68	17.9	186	0.54	65	
40	70	113	1.2	71	35	145	0.79	67	23	166	0.61	64	12.5	195	0.43	60	
49	57	98	0.85	69	29	125	0.58	64	18.4	142	0.45	61	10.2	166	0.31	57	
56	50	101	0.79	67	25	127	0.54	62	16.1	145	0.42	58	8.9	169	0.29	54	
70	40	94	0.62	63	20	117	0.42	58	12.9	133	0.33	54	7.1	154	0.23	50	
80	35	88	0.53	61	17.5	110	0.37	55	11.3	124	0.29	51	6.3	144	0.20	47	
100	28	80	0.41	57	14.0	99	0.28	51	9.0	112	0.22	47	5.0	125	0.15	43	

⚠ ATTENZIONE!

Per situazioni con velocità di ingresso particolari attenersi alla tabella pagina A2.

I pesi riportati sono indicativi e possono variare in funzione della versione del riduttore.

N.B. Per i riduttori evidenziati dal doppio bordo nella colonna delle potenze è necessario verificare lo scambio termico del riduttore (come nel par. 1.7-A). Per maggiori informazioni contattare l'ufficio tecnico STM.

⚠ WARNING!

If in presence of non standard input speed please attain to the page A2.

Listed weights are for reference only and can vary according to the gearbox version.

NOTE. Please pay attention to the frame around the input power value: for this gearboxes it's important to check the thermal capacity (comp. chapter 1.7-A). For details please contact our technical department.

⚠ ACHTUNG!

Mit unstandardisierte Antriebsgeschwindigkeit bitte auf Seite A2.

Die angegebenen Gewichte sind Richtwerte und können je nach Getriebeversion etwas variieren.

HINWEIS. Sind in den Tabellen Nennleistungen eingerahmt, so ist die thermische Leistungsgrenze der Getriebe zu beachten (s. S. 1.7-A). Für weitere Informationen wenden Sie sich bitte an unser technisches Büro.