

DRUM BRAKE

TE-I

M 1501 314 E-EN-2012-08

for Ed-thruster | per AISE 11 standard

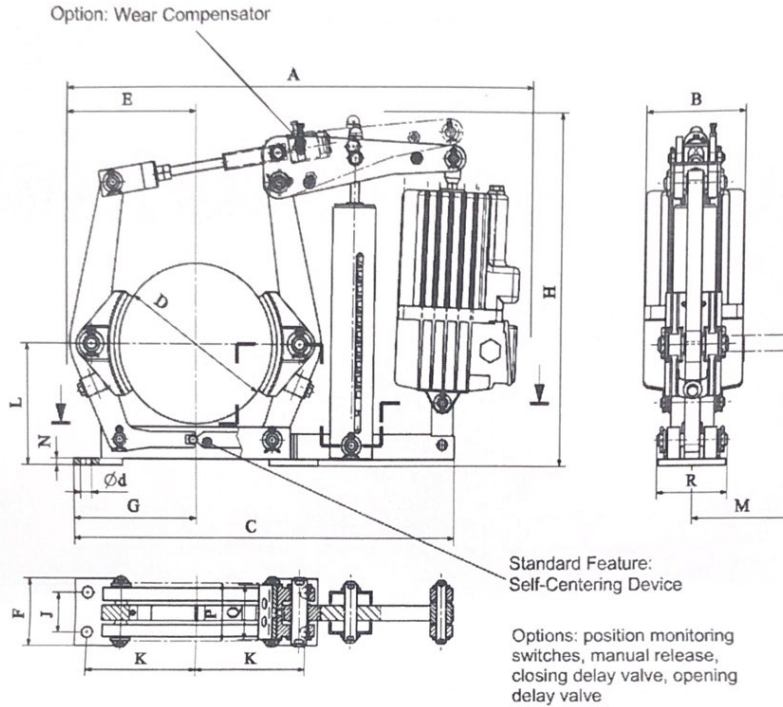

BRAKE TYPE with Eldro	Nm with $\mu = 0,4$			A	B	C	D	E	F	G	H	J	K	L	M	N	P	Q	R	d	kg*	
	min	Max. 1	Max. 2																			
TE-I 8/23/5	50	200	300	640	160	515	203	170	190	160	475	146	83	178	125	10	87,4	82,4	83	17,5	19	
TE-I 8/30/5	85	-	400																			
TE-I 10/23/5	40	300	325	760	160	595	254	210	202	170	570	158	102	213	153	33	107	101,6	113	17,5	30	
TE-I 10/30/5	40	-	450																			
TE-I 10/50/6	100	-	850	800	195						580											
TE-I 13/23/5"	70	-	420	885	160						660											
TE-I 13/30/5"	70	-	550			700	330	270	286	206		228	146	251	176	37	146	140	126	21,5	50	
TE-I 13/50/6"	75	800	1050	925	195						670											
TE-I 13/80/6"	90	-	1700																			
TE-I 16/30/5	80	-	575	1030	160						765											
TE-I 16/50/6	100	-	1100			195	860	406	315	328	260	795	274	190	308	251	32	172	165	167	26	85
TE-I 16/80/6	100	1400	1800	1075	240																	
TE-I 16/121/6	125	-	2750																			
TE-I 19/50/6	200	-	1400	1190	195																	
TE-I 19/80/6	200	-	2300			962	483	385	400	292	870	330	235	337	303	13	222	216	202	26	130	
TE-I 19/121/6	200	2800	3400	1225	240																	
TE-I 19/201/6	200	-	5400																			
TE-I 23/121/6	500	-	3300																			
TE-I 23/201/6	500	5450	5500	1365	240	1138	584	460	485	388	1030	406	298	403	348	15	286	280	232	33	206	
TE-I 23/301/6	500	-	8200																			

Max. 1 = max torque for AISE-Applications | Max. 2 = max. torque for General Applications

* kg without thruster