

Turkish Copper Industries

TÜRKBAKIR
Copper Mould
for Continuous Casting Machine

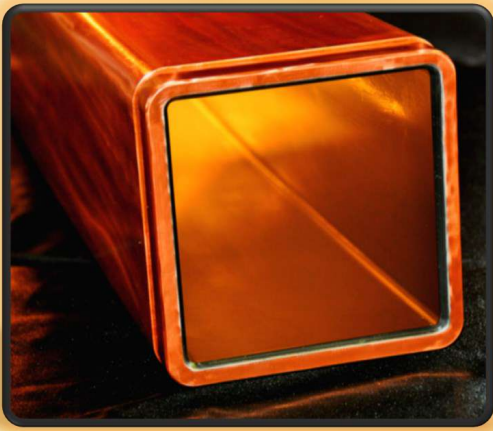

ABAX

ABAX

ABAX International was established in 2003 specialising in continuous casting machines, engineering and consumables. ABAX International is headquartered in France, and has been serving the iron-steel producers all around the world.

ABAX opened ABAX Asia for the Asian market, than ABAX Turkey and Turkish Copper Industries (TCI) in Turkey.



Turkish Copper Industries

With state-of-the-art facilities and advanced mould production and refurbishment technology, Turkish Copper Industries (TCI) produces and refurbishes copper moulds for over 120 continuous casting machines in 25 countries worldwide.

TCI is located in the heart of Turkish Steel Industry and in strategic location for faster deliveries, TCI concentrates on providing European quality tubes to especially Europe, Middle East and CIS countries.



Contact Information

Turkish Copper Industries	ABAX France	ABAX Turkey
Yeni Sanayi Sitesi 1249 Sokak No. 5 F/G İzmir –Turkey Phone: +90 232 618 02 28 Fax: +90 232 618 02 28 info@trcopper.com http://www.trcopper.com	9 Place Kléber 67000 Strasbourg - France Phone: +33 680080139 Fax: +33 680080139 sergio.abax@gmail.com	Yeni Sanayi Sitesi 1249 Sokak No. 5 F/G İzmir –Turkey Phone: +90 232 616 48 49 Fax: +90 232 618 48 50 info@abax.com.tr http://www.abax.com.tr

Copper Mould
for Continuous Casting Machine



New Moulds

for all billet and bloom casters

ABAX-TCI produces all kinds of tapers and sizes of copper moulds with higher quality.

Innovative Design

Productivity, operation and quality of the casting machine depend to a large extent on the efficiency of the mould. High speed of over 4.5 m per minute requires intensive and uniform heat-flux which can be achieved with innovative ABAX mould design.

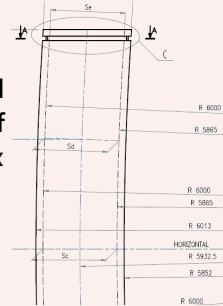

Problem Solving Enhancements

We guide and advise our customers to the optimum geometry for a given situation with the aim to solve existing problems (breakouts, billet-quality, and low productivity). ABAX-TCI has an extensive know-how on mould geometry (taper, corner-radius) for peritectic steel grades which are typically cast by all rebar producers, gained by years of research and development.

New tubes are designed for maximum heat transfer rate from the meniscus down to the bottom of the tube. The taper-geometry depends on the steel-grades and casting conditions and it is designed with the aim of minimizing the gap between the solidifying shell and the copper tube.

Longer Service Life

Extra-long service-life is achieved with the multilayer *CerMold* plating. This multilayer structure features high micro hardness and optimum binding strength with the copper base.

Heat Transfer

New tubes are designed for maximum heat transfer rate from the meniscus down to the bottom of the tube. The taper-geometry depends on the steel-grades and casting conditions and it is designed with the aim of minimizing the gap between the solidifying shell and the copper tube.

Advantages of ABAX-TCI Moulds



- High casting speed
- Uniform shell growth
- No sticking
- Optimum billet quality
- Long service life
- Low cost

Copper Mould
for Continuous Casting Machine

Material Compositions

Different copper mould materials and characteristics are used for different applications for best performance and quality. ABAX uses and suggests the following material compositions used by each application below:

By refurbishing, the used tube goes through a number of processes, it is reshaped, copper coated, machined and brand new chromium coating is implemented to reach high performances.

Material	CuDHP	CuAg	CuCrZr
Chemical Composition	P 0.015 - 0.040	Ag 0.08 - 0.12	Cr 0.30 - 1.20
		P 0.004 - 0.012	Zr 0.03 - 0.30
Application	Tubular Moulds	Tubular & Plate Moulds	Tubular & Plate Moulds
Mechanical Properties		Tubular / Plate	Tubular / Plate
Ultimate Tensile strength at 20°C (MPa)	295	300 / 275	415 / 400
Ultimate Tensile strength at 200°C (MPa)	-	245 / 230	385 / 370
0.2 % Proof Stress at 20°C (MPa)	270	275 / 260	340 / 310
0.2 % Proof Stress at 200°C (MPa)	-	230 / 210	320 / 280
Elongation at 20°C (%)	20	18 / 18	20 / 20
Hardness at 20°C (HB)	93	95 / 90	125 / 120
Physical Properties			
Coefficient of thermal expansion at 20 °C (K ⁻¹)	1,68 10 ⁻⁵	1,68 10 ⁻⁵	1,70 10 ⁻⁵
Thermal conductivity at 20°C (W/(m.K))	340	377	325
Electric conductivity (%IACS) - minimum values	83	93	80
Recrystallisation Temperature (°C)	330	370	700
Softening Temperature (°C)	-	-	500
Young Modulus (MPa)	1,2 10 ⁵	1,2 10 ⁵	1,3 10 ⁵



Mould Refurbishment

TCI brings the refurbishment technology to Turkey. Refurbishment process helps to reduce tube costs for all steel plants, significantly.



Refurbished tubes perform as good as the original tubes. Statistically life time of a refurbished tube is same as the new TCI tube's life time.

By refurbishing, the used tube goes through a number of processes, it is reshaped,



TCI refurbishes tubes sections between 130mm to 350mm and any kind of mould geometry including Single, Parabolic, Multi, Convex tapers by running 20-step-process for each tube.

Copper Mould
for Continuous Casting Machine



Quality Reports

Both refurbished and new tubes are delivered with inspection/quality reports guaranteeing the quality of the tubes.

Manuf.No	Mould. No	Material	Quantity	Billet (mm x mm)	Length (mm)	Machine Radius (m)	Weight (kg)
	14	CuAg0.1		140x140	1000		74.4

1. INSIDE DIMENSIONS

Nom. Diameters & Tolerances	A-C	144.5±0.2	Distance from Top	A-C		B-D	
	B-D	142.5±0.2		Drawing	Measurement	Drawing	Measurement
			1-	145,90	145,93	143,90	143,91
			2-	145,81	145,84	143,81	143,88
			3-	145,33	145,36	143,33	143,39
			4-	145,05	145,08	143,05	143,11
			5-	144,92	144,99	142,92	143,00
			6-	144,79	144,84	142,79	142,87
			7-	144,72	144,79	142,72	142,80
			8-	144,85	144,85	142,85	142,70
			9-	144,80	144,81	142,80	142,83
			10-	144,55	144,52	142,55	142,57
			11-	144,50		142,50	

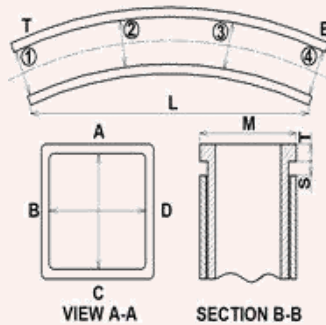

2. THICKNESS & ECCENTRICITY

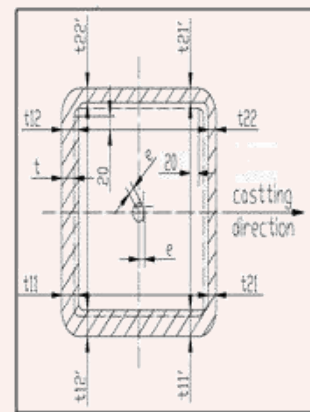

TOP	T12	14,40	T22	14,37	$\frac{T12+T22}{2}$	28,77	$e = T12-T22 /2$	0,02
	T11	14,42	T21	14,41	$\frac{T11+T21}{2}$	28,83	$e = T11-T21 /2$	0,00
	T12'	14,41	T22'	14,44	$\frac{T12'+T22'}{2}$	28,85	$e = T12'-T22' /2$	0,01
	T11'	14,37	T21'	14,39	$\frac{T11'+T21'}{2}$	28,76	$e = T11'-T21' /2$	0,01
Bottom	T12	13,41	T22	13,38	$\frac{T12+T22}{2}$	26,79	$e = T12-T22 /2$	0,01
	T11	13,36	T21	13,39	$\frac{T11+T21}{2}$	26,75	$e = T11-T21 /2$	0,02
	T12'	13,36	T22'	13,39	$\frac{T12'+T22'}{2}$	26,75	$e = T12'-T22' /2$	0,02
	T11'	13,42	T21'	13,41	$\frac{T11'+T21'}{2}$	26,83	$e = T11'-T21' /2$	0,00

$e = \leq 0.03 T$ or see drawing description

Drawing: TCI 160-1

spec. 10

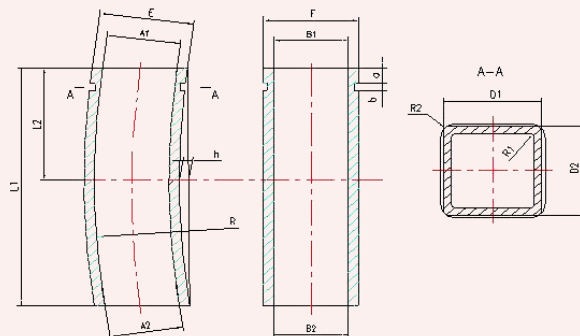

E1	E2	F1	F2	L1	L2	a	b	D1
197±0,25		195±0,25		1000±0,5	390±0,25	12±0,05	8±0,2±0,1	182,8±0,1
196,83	196,85	194,85	194,85	1000	OK	12,00	8,00	182,82
196,84	196,85	194,86	194,85	1000,00	OK	12,00	8,00	182,80
196,82	196,83	194,86	194,86	1000	OK	12,00	8,00	182,80
196,86	196,85	194,85	194,85	1000	OK	12,00	8,00	182,82
196,84	196,84	194,84	194,86	1000	OK	12,00	8,00	182,81
196,85	196,85	194,85	194,83	1000	OK	12,00	8,00	182,80
196,85	196,84	194,86	194,86	1000	OK	12,00	8,00	182,80
196,86	196,85	194,85	194,85	1000,00	OK	12,00	8,00	182,81
196,85	196,86	194,84	194,85	1000	OK	12,00	8,00	182,81

Copper Mould
for Continuous Casting Machine

Other CCM Products

ABAX-TCI also produce supporting equipments for Continuous Casting Machines:

MouldStar[®] Electromagnetic Mould Level Detection System

MouldStar Electromagnetic mould level detection system manages the level of liquid steel in the copper mould without radioactivity. This system effectively controls the liquid steel level and contributes to the stability, reliability of the casting process. MouldStar not only makes the operation more efficient, it also improves the mould life time, eliminates human error and saves costs of accidents.

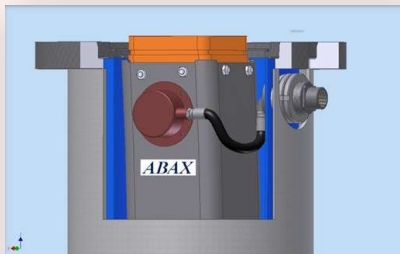

ABAX Mould Housing[®]

ABAX also produces mould housing for ABAX-TCI copper moulds according to customer requirements.

ABAX-TCI is a one-stop-supplier for moulds, mould jackets and mould housings. Purchasing ABAX mould products together prevents any compatibility problems and leads to more effective and efficient systems.

ABAX CCM Projects and Equipments

ABAX engineers and delivers turn-key CCM projects for new plants and also makes re-vamping projects to increase the casting capacity, to improve the efficiency of existing CCMs.

With the vast knowledge in these projects, the project team of engineers from Europe, Turkey and China, ABAX offers high quality CCM projects and equipments.

To have more information on CCM projects please do not hesitate to contact ABAX International or ABAX Turkey from the contact details provided in the Company Profile page.



Supporting Products

Copper Mould
for Continuous Casting Machine

References Around the World



ArcelorMittal



Ferrier Valsabbia



KOÇÇELİK



KROMAN
ÇELİK SANAYİİ A.Ş.

PLATINUM
DEMİR ÇELİK SANAYİ VE TİCARET ANONİM ŞİRKETİ



حديد الإمارات
emirates steel



TOSYALI
HOLDİNG

ÇEBİTAŞ



مجتمع فولاد صنعت بناب
Bonab Steel Industry Complex



BASTUÇ
METALURJİ SANAYİ A.Ş.

ezzsteel
The Middle East Steel Professionals

Feralpi Group



KURUM
DEMİR



EKİNCİLER



GeoSteel
LLC

Çolakoğlu Metalurji



TŘINECKÉ ŽELEZÁŘNY



SİDDİK KARDEŞLER
Demir Çelik Sanayi



ŽELEZIARNE®
PODBREZOVA



COST

HELLENIC
HALYVOURGIA

PROMETAL
ALGERIE

ÖZKAN®
DEMİR ÇELİK SANAYİ A.Ş.



EGE ÇELİK



PITTINI
FERRIERE NORD

MOUNTAIN
STEEL

ESCO
Esfahan Steel Company

Univers Acier
العالمية للصلب

Yesilyurt