

BASEKT MILL TECHNICAL SPECIFICATION

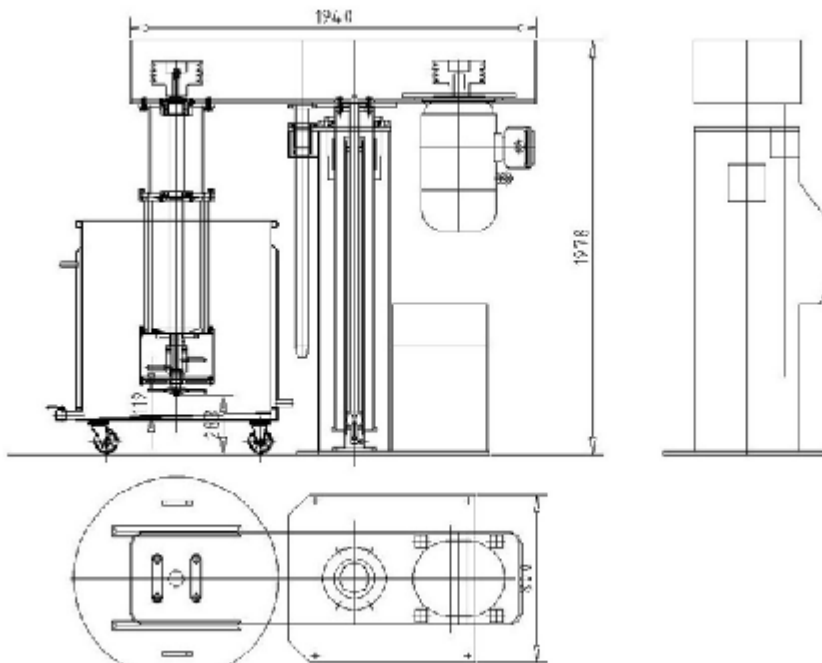
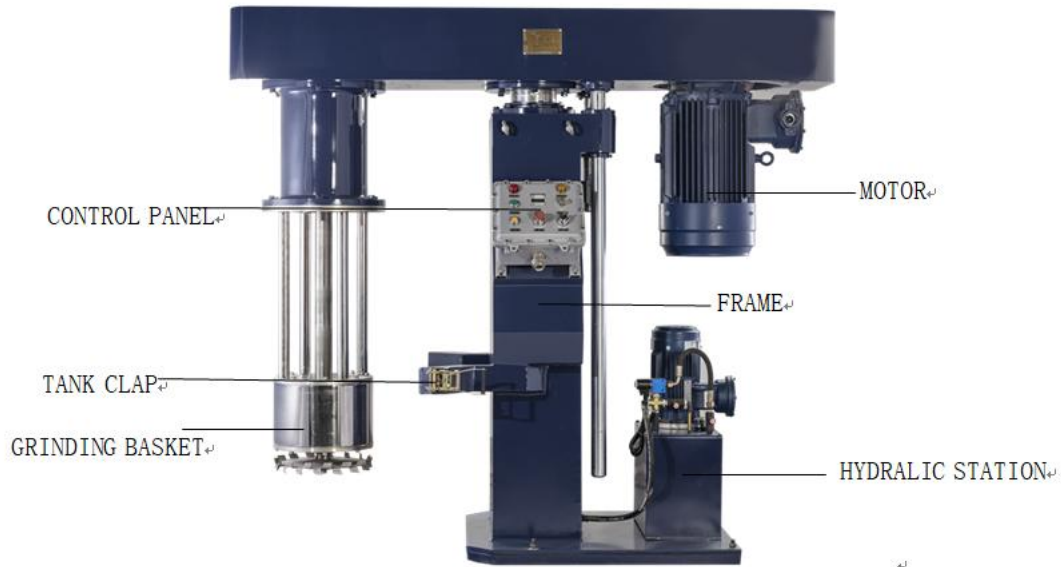

BASKET MILL WORKING PRINCIPLE

The milling basket, containing the grinding sand is lowered into the millbase, the fast circulation of the millbase within the mill basket is generated by the dissolver disk and integrated pump wheel, a very narrow particle size distribution can be achieved very quickly.

- | Mostly suit for small batch, colorful product, dispersing and grinding are finished in one container.
- | Easy cleaning, no residues, convenient product replacement.
- | Little grinding media requested, Excellent grinding efficiency and effect.
- | Double-walled container for cooling or heating

BASKET MILL TECHNICAL DATA:

1). SHAFT PART DETAILS:

- u **75kw x380V x 50HZ x 4P, Ex-Proof type,**
Famous Chinese brand, Wannan Brand; Protection degree:IP55, Ex e IIB T3
- u mixing shaft support column with bearing set, SKF Japan Imported bearings
- u SUS304 mixing shaft with computer balancing, Mirror polishing
- u SUS 304 grinding basket body :70L working volume. **With cooling function for the basket**
- u Contacting material:**grinding rods, Ceramic material, more higher anti-wearing and resistant.**
Easy replacement and cleaning
- u pump wheel:alloy steel ,dispersing disk:SS304;fast material suction bead separator: alloy steel
- u **shaft speed: 0---1000rpm,with 45kw inverter adjusting the speed,**
Famous Chinese brand Holip.

2). MACHINE STRUCTRE DETAILS:

- u Carbon steel after polishing ,then with epoxy coating, solvent resistance painting.
- u Color :Standard color is blue or white and blue. Also can be customized
- u Keeping left and right side of supporting column balancing
- u With dust cover on basket mill and can be raised /fall down with mill,SS304
- u **With tank arms to position and fix tank:** carbon steel painting and chrome plating
- u Belt wheel with computer balance

- u With 2 direction -guide bars

3). HYDRAULIC SYSTEM DETAILS:

- u 2.2 kw x 380V x50HZ x3Ph,price without motor
- u Hydraulic oil pump.
- u Double action hydraulic cylinder.
- u Hydraulic pressure control valve and safety valve.
- u Lifting height:1500mm

4). ELECTRIC CONTROL SYSTEM DETAILS:

- u Equipped with power cabinet in which prewired with Contactors, MCCB, Isolator, Relay, Timers ,cooling fans , Inverter for Speed control assembled in Control console. stand in non explosion-proof zone
- u Main buttons on operation panel: basket mill switch ,Speed increase ,Speed decrease ,HYD raise ,HYD drop; machine stop and start, Emergency stop.
- u Main meter, digital display:speed meter ,ampere meter ,temp meter
- u Main light:Power sign IDCT,Mill running IDCT
- u Electric part Schneider

5). SAFETY SYSTEM DETAILS:

- u Stroke limitation for sole operation in the safe working area of the tank
- u Monitoring of the tank clamping device to ensure tank is clamped before use
- u Automatic speed feedback at overload operation
- u Line break safety in the hydraulic line to prevent uncontrolled lowering of the machine
- u Machine start-up at the lowest speed
- u Access protection for rotating agitator shaft to prevent operator injury
- u Emergency stop

6). BASKET MILL VESSEL DETAILS:

- u Total volume:2154L working volume:2000L,1400*1400*5mm , with SS304 cooling jacket ,SUS304(thickness:3mm)
- u With diagonal bottom,it is easy to discharge

- u With four wheels,two are single direction,the other two are round direction
- u Inside and outside mirror polishing,easy to clean,without residue.
- u One DN25 discharge port with discharging ball valve,SUS304.

7). COMPANY DETAILS:

FARFLY was founded in 2003 with a registered capital of 10 million RMB. The headquarter is located in International Plaza of Hongqiao Business District in Shanghai. Production factory is located in Jiangsu Wuxi Gushan Industrial Park, which covering an area of over 18,000 square meters. We are the professional chemical manufacturer and exporting to over 80 countries,providing more than 10,000 equipment to all over the world.

8). FACTORY OVERIEW:



many high-technology manufacturing equipment



high strictly quality control system (QC)



Four working plants of factory



Each equipment meet European standard, with CE certification. ISO qualified.



We are member of coating association in China。 At 2010 year, we passed the ISO9001-2008 **quality management system certification** , all the product from design, production, procurement, installation, commission , testing, and final get in stock should in full accordance with the requirements of the quality management system. At all series product meet the European standard CE certification. Parts high-quality products got the patents