

Innovative Power Transmission

Slide Bearings Type **E**

Series **EF** Journal Range 80-355 mm

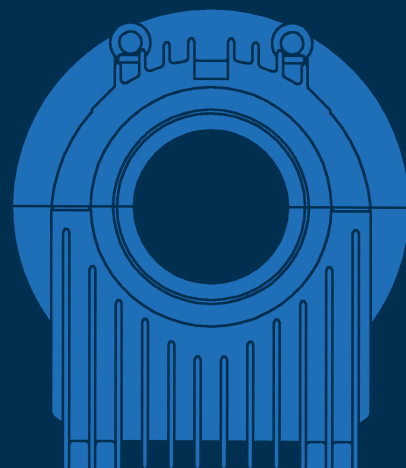

This leaflet contains information which should be considered for the majority of applications where EF-type bearings are used with electric machines. All the other facilities of the E-type bearing modular system will, of course, also apply to EF-type bearings: e.g. bearing shells with two- or four-lobe bore, with journal tilting pads or RD thrust pads. Relevant details will be found in the main catalogue on "RENK Slide Bearings Type E".

All parts of the variants mentioned in this leaflet are available from stock.

Bearing Housing

The finned EF-type housings are made from a high-quality cast iron (EN-GJL-300) and are designed for heavy duty performance. Other materials such as, for instance, nodular cast iron EN-GJS-400-15 or cast steel GS 45 can be supplied by special arrangement.

Bearing Shell

The shells are spherically seated in the housing. They consist of a supporting steel body lined with lead based RENKmetal therm 89/V6. Both design and manufacture are in accordance with the highest standards required in heavy engineering: trouble-free assembly and long life even under severe operating conditions.

EF-type bearings are mostly equipped with shells with plain cylindrical bore and lubricating oil ring. Shells are available either for self-contained operation (E.NL.) or prepared for external oil circulation (E.ZL.).

Apart from bearings without thrust parts (type...Q) there are shells with plain white-metal lined shoulders (type...B) to absorb limited noncontinuous axial loads, as well as shells with built-in taper land faces (type...K) which will absorb medium axial loads. Alternatively the taper land faces can be supplied suitable for only one sense of rotation (type...E) to absorb high axial loads.

Seals

EF-type bearings with floating labyrinth seals (type 10) are used for standard applications. They consist of a fibre-reinforced, highly heat resistant material RENKplastic therm P 50, and are not subject to wear. This seal conforms to protection grade IP 44. Higher protection grades (up to IP 56) can be fitted under the modular system.

To protect machines fitted with EF-type bearings against any interference from inside (e.g. vacuum or strong air circulation), EF-type bearings should be used generally only with additional "machine seals". Such seals are fitted to the inside of the machine end shield forming a sealing gap with the shaft.

RENK Hannover can supply a machine seal (made of a non-corrosive alloy). Optionally the air-tightness of this machine seal can be improved by inserting a hemp tallow packing in the standard circumferential groove of the seal.

The space between housing and machine seal is connected to atmosphere so that no vacuum or strong air turbulence can occur at the internal bearing seal.

Oil Supply

Self-lubrication by means of a loose oil ring for peripheral shaft speeds up to 20 m/s. The lubricating oil delivered to the internal perimeter is transferred by the loose oil ring directly to the shaft. Where bearings are lubricated by oil circulation systems, loose oil rings can be used with peripheral shaft speeds of up to 26 m/s to permit emergency shut-down without damage. Loose oil rings can also be used for marine applications. In this case additional guide bushes are built into the shells.

Electrical Insulation

As protection against stray currents conducted by the shaft, EF-type bearings can also be supplied in insulated version. To do so, the spherical bearing shell seating within the housing is electrically insulated by using a plastic shell firmly stuck to the housing or an insulating foil. All EF-type bearing housings "with spherical insulation" are available from stock.

Heat dissipation

Frictional heat is often dissipated merely by radiation and convection only: "natural cooling". Depending on the shaft diameter, speeds of up to 3600 min⁻¹ are admissible.

Because of their advanced design, EF-type bearings with natural cooling can now be used for a wide range of applications.

Oil coolers (with seawater-resistant finned cooler tubes) incorporated in the oil sump can be used in addition. Dimensions on request. EF-type bearing housings are generally suitable for connection to an oil circulating system.

In such case the oil level in the housing is defined by the weir in the oil outlet pipe of our supply.

Temperature Control

Two independent thermosensors which are commercially available can be used for temperature control. We recommend the use of RENK resistance thermometers or RENK angle thermometers for direct visual control.

Oil Selection

Generally any branded mineral oil of low foaming tendency and good resistance to ageing can be used as a lubricant. The correct viscosity for each operating condition should be checked by EDP calculation. Such calculations are carried out at the design stage. A printout of the results computed can be provided on request.

Dimensions of Bearings (DIN 31 694)

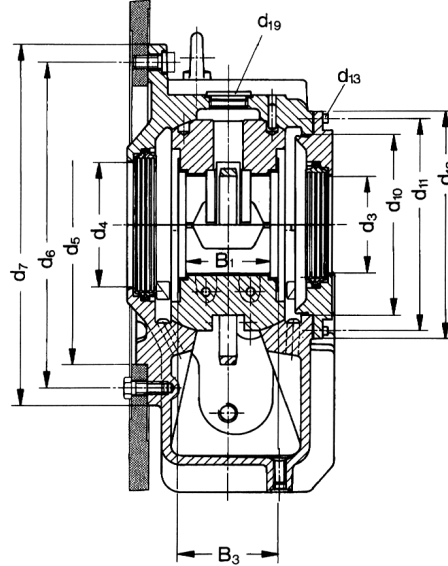
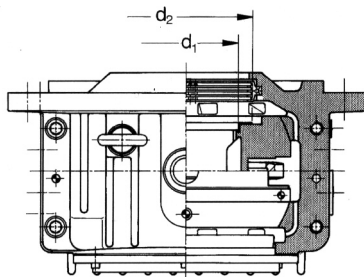
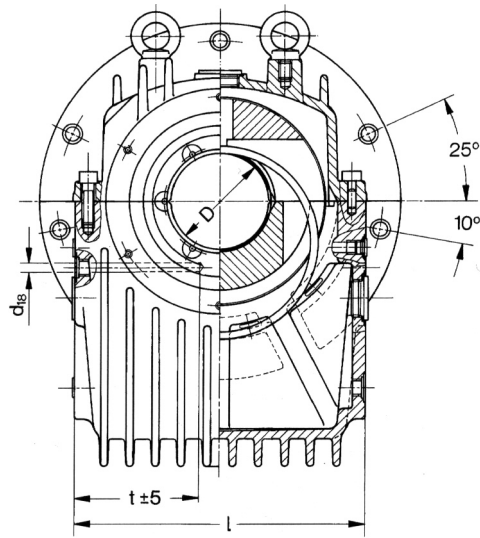

EF. LB
EF. LK
EF. LE

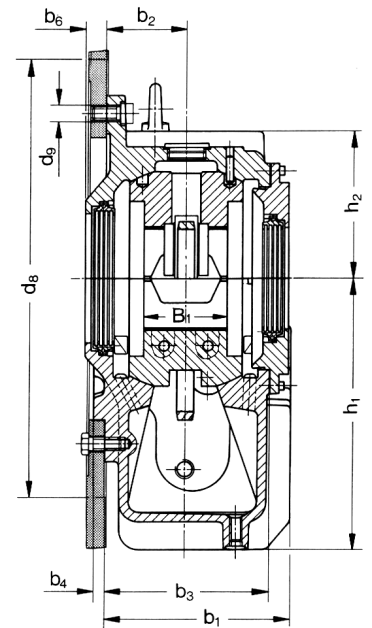

EF. LQ

- d_{1,4} = oil inlet if connected to oil circulating system or circulating pump
- d₁₅ = thermometer connection
- d₁₆ = oil level or oil outlet if connected to oil circulating system
- d₁₇ = screw plug for oil sump thermometer, suction line of circulating pump connection of heater (or modified for finned tube oil cooler optionally)

From bearing size 14 larger bore diameters are possible (information upon request).

Dimensions in mm

Size	D	B ₁	B ₃	b ₁	b ₂	b ₃	b ₄	b ₅	b ₆	b ₁₉	d ₁	d ₂	d ₃	d ₄	d ₅	d ₆	d ₇	d ₈ ²⁾	d ₉	d ₁₀	d ₁₁	
9	80	61,4									86	110										
	90	61,4	80	162	70	140	14	12	23	215	96	120	80/90/100/110	100	280	310	340	420	14	150	170	
	100	65	-0,22								106	130										
11	100	81,4									108	135										
	110	81,4	100	192	80	165	15	17	29	235	118	150	100/110/125/140	125	315	350	380	460	14	180	195	
	125	85	-0,22								133	160										
14	125	105,4									135	170										
	140	105,4	125	232	100	205	16	23	26	285	150	190	125/140/160/180	160	355	415	460	550	18	230	270	
	160	106,4	-0,22								170	200										
	180 ¹⁾	106,4									190	220										
18	160	135,7									172	215										
	180	135,7	160	273	116	241	18	25	31	315	192	240	160/180/200/225	200	400	490	540	640	22	275	320	
	200	140,4	-0,22								212	250										
	225 ¹⁾	140,4									237	275										
	200	168,5									214	265										
22	225	168,5									239	290										
	250	175,7	200	354	150	314	20	37	32	395	264	315	200/225/250/280/300	250	500	620	680	785	26	340	380	
	280 ¹⁾	175,7	-0,22								294	345										
	300 ¹⁾	175,7									310	345										
	250	213,2									266	325										
28	280	213,2									296	355										
	300	218,5	250	414	170	365	30	42	43	475	316	375	250/280/300/315/355	315	600	770	850	970	33	440	500	
	315	218,5	-0,24								331	390										
	335	218,5									351	410										
	355	218,5									371	430										

¹⁾ Available only with shells B and Q.

²⁾ Diameter of finished surface of machine end shield.

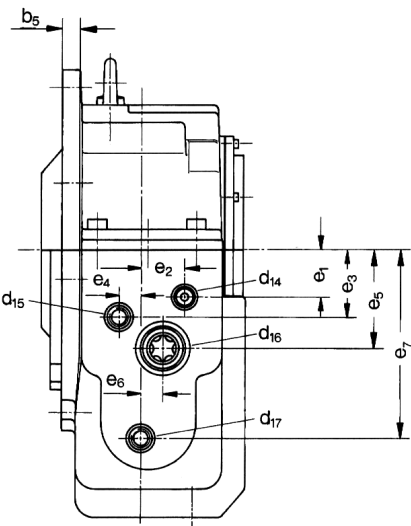

- ① Type E
- ② Housing M = centrally flange-mounted
- ③ Heat dissipation
 - N = natural cooling
 - Z = lubrication by oil circulation with external oil cooling
 - X = lubrication by oil circulation with external oil cooling for high oil throughput
 - W = water cooling (finned tube cooler in oil sump)
 - U = circulating pump and natural cooling
 - T = circulating pump and water cooling
- ④ Shape of bore and type of lubrication*)
 - L = plain cylindrical bore, with loose oil ring lubrication
- ⑤ Thrust surface*)
 - Q = without thrust parts (non-locating bearing)
 - B = plain sliding surfaces (locating bearing)
 - K = taper land faces for both senses of rotation (locating bearing)
 - E = taper land faces for one sense of rotation (locating bearing)

*) = if not mentioned see main catalogue, details on request

Example

for quoting a slide bearing type EF, lubrication by oil circulation with external oil cooling, cylindrical bore with loose oil ring lubrication (for emergency operation), thrust part with taper land faces, size 14, shaft diameter 125 mm:

① ② ③ ④ ⑤

Slide bearing E F Z L K 14-125

The indicated weights are average values (not binding). The drawings are not strictly binding.

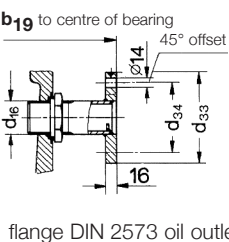

As for bearing types E.Z.L., the oil outlet with weir is to be mounted horizontally at the bottom. The mark at the flange will then be visible centrally at the top.

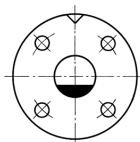

d ₁₂	d ₁₃	d ₁₄	d ₁₆	d ₁₈	d ₁₉	d ₃₃	d ₃₄	e ₁	e ₂	e ₃	e ₄	e ₅	e ₆	e ₇	h ₁	h ₂	l	t ¹⁾	weight [kg]	oil quantity [litres]
190	6 x M6	G 3/8	G 1 1/4	11	G1	120	90	35	35,5	60	20	85	22,5	175	250	130	270	115 115 115	46	2,8
215	6 x M6	G 3/8	G 1 1/4	11	G1	120	90	40	42	70	22,5	100	22,5	195	280	145	310	135 135 127	74	4,7
290	6 x M6	G 3/8	G 1 1/2	11	G1 1/2	130	100	60	55	85	27,5	125	27,5	240	340	185	370	165 145 125	125	8
340	8 x M8	G 1/2	G 1 1/2	13	G2	130	100	70	68	105	30	155	30	270	400	225	440	197 197 175 150	200	13
400	8 x M8	G 3/4	G 2	13	G2	140	110	80	83	135	40	175	40	350	450	275	550	252 252 238 192 177	430	21
525	8 x M8	G 3/4	G 2 1/2	13	G2	160	130	95	106	155	50	220	50	400	500	325	690	322 322 272 267 242 229	770	34

Shaft Dimensions

Locating bearing

Type of bearing shell E...B
E...K
E...E

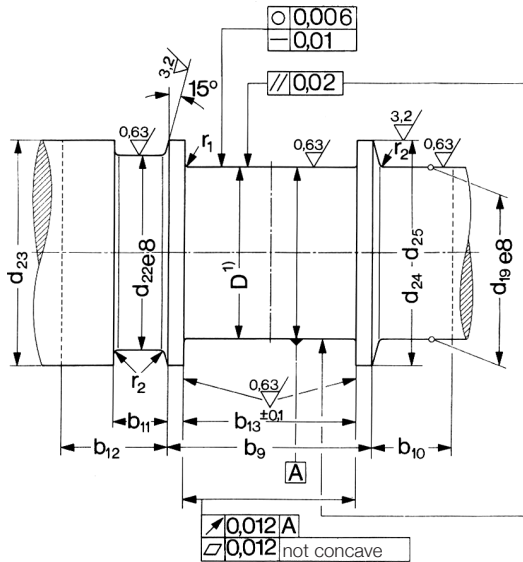

Non-locating bearing

Type of bearing shell E...Q

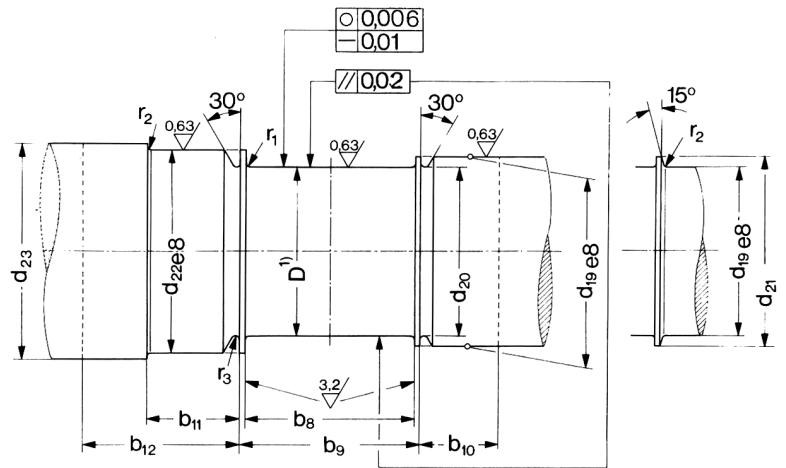

chamfered edges 0,5 x 45°
surface condition DIN ISO 1302

Dimensions in mm

Size	D ¹⁾	b ₈ ²⁾	b ₉	b ₁₀	b ₁₁	b ₁₂	b ₁₃ ³⁾	$\frac{d_{19}}{d_{20}}$		d ₂₁	d ₂₂	d ₂₃ ⁴⁾	d ₂₄	d ₂₅	r ₁	r ₂	r ₃		
9	80							80	90	100	110	90	110	110	132				
	90	90	100	55	60	95	80,4	-	80	90	100	100	100	120	142	2,5	4	1,6	
	100											110	130	130	143				
11	100											110	135	135	157				
	110	110	120	50	55	105	100,4	100	110	125	140	125	125	150	162	2,5	4	1,6	
	125											140	160	160	168				
14	125							125	140	160	180	140	160	170	192				
	140											160	160	190	207				
	160	140	150	60	60	115	125,4	-	125	140	160	180	160	200	217	4	6	2,5	
	180											200	180	220	220	-			
18	160											180	200	215	244				
	180							160	180	200	225	200	200	240	264				
	200	180	188	60	65	120	160,4	-	160	180	200	225	200	250	273	4	6	2,5	
	225											250	225	275	275	-			
22	200											225	250	265	308				
	225											250	250	290	328				
	250	220	240	70	70	135	200,4	200	225	250	280	280	250	315	339	6	10	4	
	280											315	280	345	345	-			
	300											330	300	345	345	-			
28	250											280	315	325	378				
	280											310	315	355	408				
	300	280	296	70	75	140	250,4	250	280	300	315	(335) ⁵⁾ 355	330	315	375	408	6	10	6
	315											315	280	390	390	423			
	335											345	315	390	390	-			
	335											365	355	430	410	-			
	355											385	355	430	430	-			

1) For shaft tolerances see "Manual for the application of RENK slide bearings".

2) Where a non-locating bearing is to permit greater axial movement (e.g. to allow for thermal expansion), the distance b₈ between the collars may be increased.

3) The normal axial clearance is 0,5 mm. When directional changes of thrust loads or where axial shocks are to be anticipated, the dimensions b₁₃ may be reduced by a further 0.3 mm.

Where a locating bearing is only required for a test run, the dimension b₁₃ can be

increased by 3...6 mm.

4) All diameters d₂₃ are for standard machine seals and are valid for each shaft diameter D. In case of rigid seals dimensions on request.

Tolerances of form and position to DIN 31 699.

Degree of accuracy B 10 (radial). Degree of accuracy B 20 (axial); others upon request. General tolerance DIN 7168 mS.

5) Rigid seal

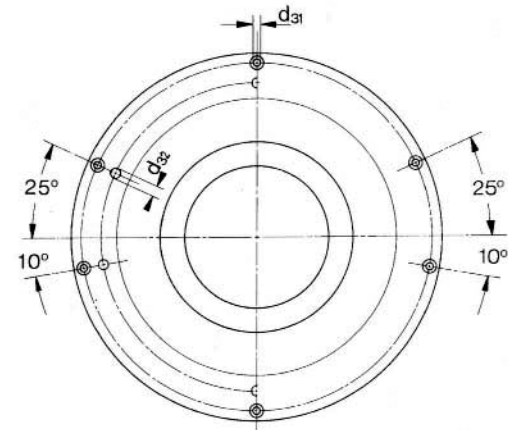
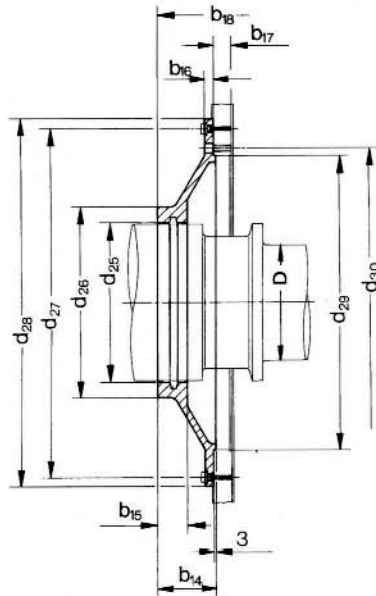

Also available in split design.

Dimensions in mm

Size	D	b ₁₄	b ₁₅	b ₁₆	b ₁₇ ¹⁾	d ₂₅ ²⁾	d ₂₆	d ₂₇	d ₂₈	d ₂₉	d ₃₀	d ₃₁	d ₃₂	weight [kg]
9	80					111,5								
	90	60	35	10	21	121,5	160	360	380	280	310	7	14	4,5
	100					131,5								
11	100					136,5								
	110	65	35	10	21	151,5	180	400	420	315	350	7	14	5
	125					161,5								
14	125					171,5								
	140	70	35	10	21	191,5	230	375	395	355	-	7	-	4,8
	160					201,5								
18	160					216,5								
	180	75	40	10	26	241,5	290	430	460	400	-	10	-	6,5
	200					251,5								
22	200					266,5								
	225	80	45	10	28	291,5	390	535	570	500	-	10	-	10
	250					316,5								
28	250					326,5								
	280	85	50	10	36	356,5	450	640	680	600	-	10	-	15
	300					376,5								

1) Min. recommend value

2) Min. inner diameter of the machine seal depends on the diameter of collars for locating bearings due to non split design.