

Dual Plate Check Valves

DUAL PLATE

A compact design which permits an immediate response regardless of flow characteristics, by means of retainerless two semi discs.



Code 43

Type: Dual Plate Wafer Check

Sizes: 2" - 48"

ANSI Class: 150-600

Tilting Disc Check Valves

Design for high flow speed getting a quick and control closing. Our especially designed shape of the disc and seat guarantee that the disc will be in contact with the seat before the reverse flow velocity has reached its maximum value. The conical design of both sealing parts helps absorbing the disc impacts better than with straight type discs, as frequently occurs with other designs of check valves.



Code 02

Type: Tilting Disc

Bonnet: Bolted

Sizes: 2" - 48"

ANSI Class: 150-900



Code 05

Type: Tilting Disc

Bonnet: Pressure Seal

Sizes: 2" - 48"

ANSI Class: 600-4500



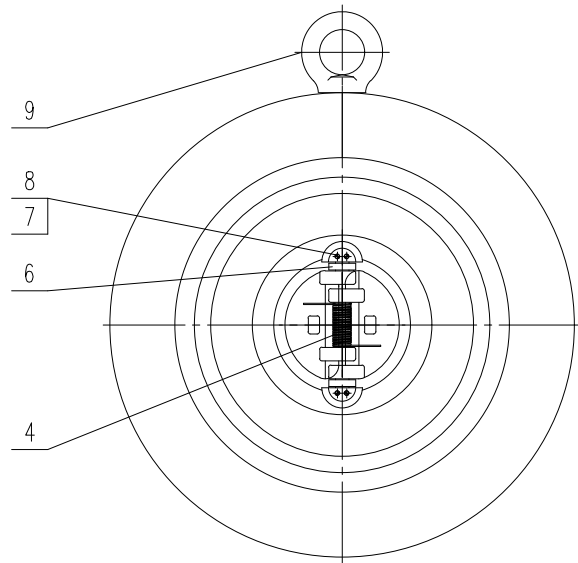
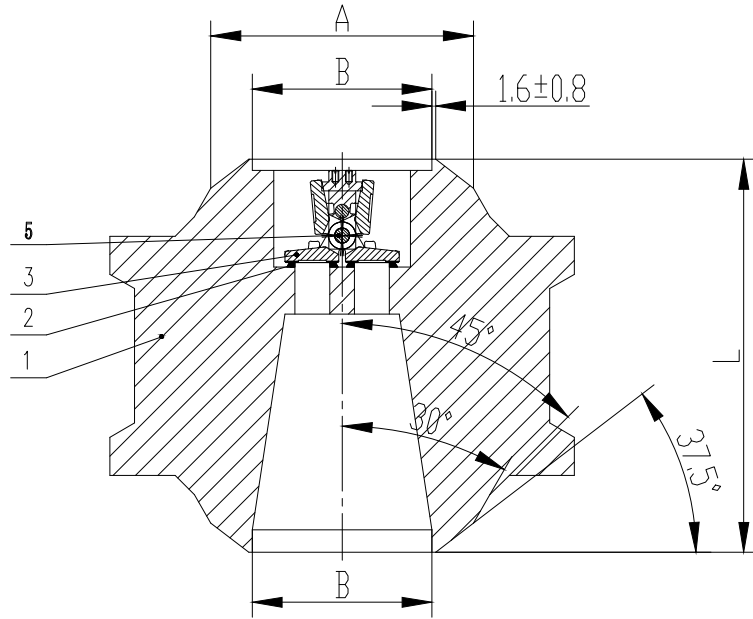
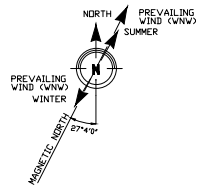

NPS	DN	Size (mm)			SCH	TAG	WEIGHT(Kg)
		L	B	A			
6"	150	240	124.4	172	XXS	95977	13.49

Specification		
Nominal pressure	1500LB	
pressure test	Shell test	38.3
	seal test	28.1
	seal test(Air)	—
Suitable temperature(°C)	-29-400°C	
Suitable medium	water,steam,oil	

- GENERAL NOTES
- Design & manufacture to API 594
 - Pressure-temperature to ASME B16.34
 - BW ends to ASME B16.25 Δ
 - Face to face dimension to FACTORY
 - Inspection & test to API 598



REFERENCE DRAWINGS	DWG NO.
1-xxxxxxxxxxxx	V20059-44

EMPLOYER:



Esfahan Oil Refining Company

PROJECT TITLE: RESIDUE HYDROTREATING PROJECT (RHU)

CONTRACT No: PMA/73-98-1638	P.O.:	XX	SCALE: N/A
MC:	CONTRACTOR:		
			

DWG TITLE: CHECK VALVE DUAL PLATE WAFER CLASS 1500

DWG No.: V20059-44 SIZE: A3 SHEET No: 1 OF 1 REV: 1

PURCHASER'S COMMENT/ APPROVAL STATUS		PURCHASER:	
1. AP: Approved (Released For Manufacturing)		NARGAN	
2. AM: Approved as Noted for Fabrication/Fabrication not Proceed		ACQUISITION NO:3667-32-74-EP-P1-5017-01	
3. NP: Approved as Noted for Re-Issue/Fabrication not Proceed		ITEM NO. (TAG NO.): 173	
4. RE: Rejected		VENDOR DOC. NO.: XX	
5. NR: Not Returned		Signature: _____	
Date: XX.XX.XX			

9	Ring Bolt	AISI 1035
8	Screw	SS304
7	Location block	ASTM A182 F6a
6	Spacer ring	ASTM A182 F6a
5	Stem	ASTM A182 F6a
4	Spring	Inconel-X750
3	Disc	ASTM A216 WCB+STL
2	Seat face	STL
1	Body	ASTM A105

NO.	PART NAME	MATERIAL
-----	-----------	----------

1	REV	DATE	DESCRIPTION	PREP'D	CHK'D	APP'D
1	01-20-2020		FOR APPROVAL	AM	AM	AM
1	01-20-2020		FIRST EDITION	AM	AM	AM

