



**XIAMEN TAKAM MACHINERY CO.,LTD.**  
 Add : 260 North Tongji Road,  
 Tong' an District ,Xiamen City, China  
 Tel : 0086 592 7362548  
 Fax : 0086 592 7362540  
 Web : www. takam. com



You can enter Takam website  
 if your phone has QR software



**KING MIDAS ENTERPRISE**  
 Add : 1310 Mountain View Circle,  
 Azusa, CA 91702 USA  
 Tel : 001-626-815-1431  
 Fax : 001-626-815-1434



You can enter Takam website  
 if your phone has QR software

# MACHINE One By Takam







- Machine is designed with wide-stance casting.
- The main 5 large components of the machine consists of the stand, base, headstock, work table, and saddle are all create from high quality HT300 cast iron.
- Custom anti-flex chamber design helps both with reducing flex and vibration.
- Unlike many companies in the machine tool industry, we do not machine our castings when we receive them. We let the cast iron sit outside in rain or sun to let the casting take its natural flex changes for 2-3 months.
- All work tables contact areas are heat treated to ensure perfect hardness to reduce any damage that might occur during usage.

### Motion Control



- M-One models uses high accuracy ballscrews constructed of high quality imported materials that have been heat treated to prevent wear from usage. Also, the ballscrews are created with an inner tubing design, this reduces noise associated with ballscrew travel by 20-40% compared to other standard ballscrews.

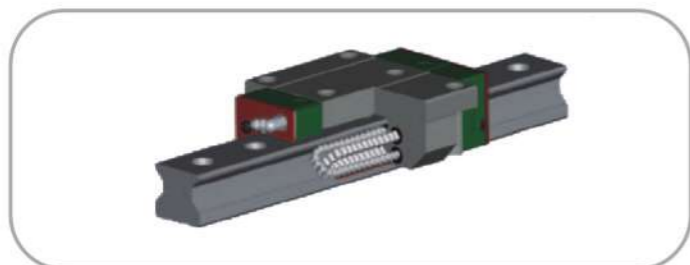

- All M-One series models uses roller type linear guide ways. High strength rollers have a great weight load capacity. Furthermore, the roller type guide ways are designed to have unbelievable tilt resistance. With P-grade roller type linear guide ways, perfect flatness is guarantee from every part machined.

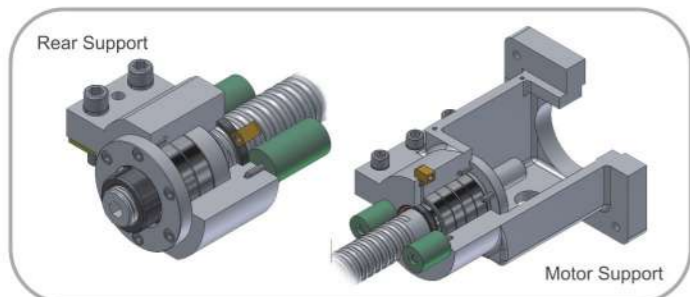

- Rigidity is the key to cutting faster, this is why we use four high accuracy heavy duty bearings in the motor mount and three high accuracy heavy duty bearings in the rear support. By doing so we increased the rigidity of the ballscrew support by 50% compare to standard machines in the industry.

### Z-Axis Head Stock Strength



- The headstock being the part that takes the most stress, the headstock is equipped with roller type linear guide ways giving the headstock incredible strength in resisting flex and harmful vibration.
- With 6 heavy duty roller blocks installed on the Z-axis headstock, consistent contact is made between headstock and stand giving the M-One incomparable rigidity.
- Unbelievable structure design gives the headstock a reduced weight and enhanced strength. This gives the M-One the ability to move faster and at the same time consuming least power, which makes the machine more eco-friendly than most machines in the industry.

### X-Axis Saddle Strength



- The X-axis saddle is designed with 4-point support. This means that there is support at every 1/4 of the distance.
- With roller type guides, the saddle and work table can withstand forces from heavy cutting. The X axis saddle is supported with 6 heavy duty roller blocks that can withstand over 2 tons and is resistant to tilt due to an unbalanced work piece.
- Heavy tension roller type guide ways were selected to reduce vibration to work piece giving higher precision cuts and finer finishes.

### Y-Axis Saddle Strength

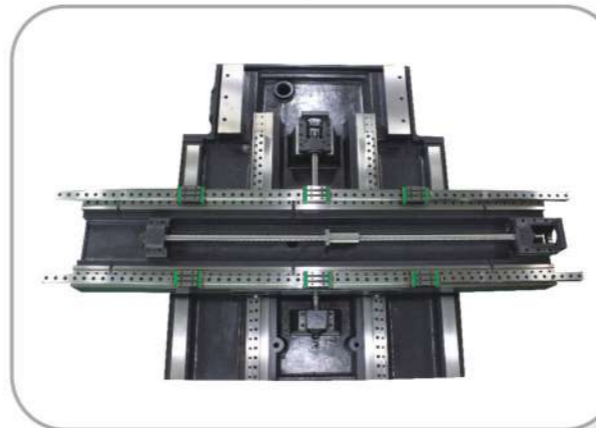

- With a base support wide as the saddle. The base gives complete and total balance to the whole machine without any problem.
- Incredible 4 roller blocks and 4 roller supports. Regardless of where the work piece lays. The work piece will still be balance to perfection.



Analysis Features

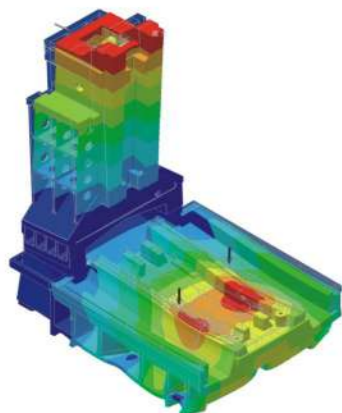

■ **Knowing Your Creation**

All M-One series machines are designed and analyzed by high tech computer software. By doing so we are able to test the rigidity under heavy machining stress and machine flex. We are one of the few manufacture by going the extra mile were able to create a machine that is balanced in weight and strength in every aspect of the machine.

Machine Shipping Features

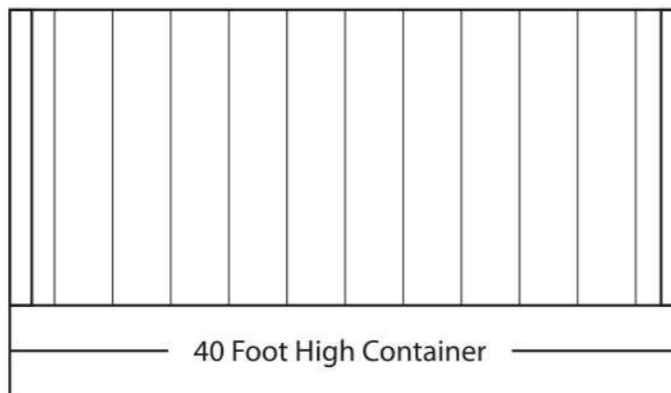

■ **40 Foot Container Fitment**

M-One6	4 Units	M-One20	2 Units
M-One8	3 Units	M-One40	2 Units
M-One10	3 Units	M-One60	2 Units
M-One11	3 Units	M-One80	2 Units

■ **Non-Dismantlement**

The M-One model machining center features one and only non dismantlement shipping. This meanings that the machine can fit in to containers without being taken apart and have to be put together again, which wastes time and money.

2-Step Gear Box Features

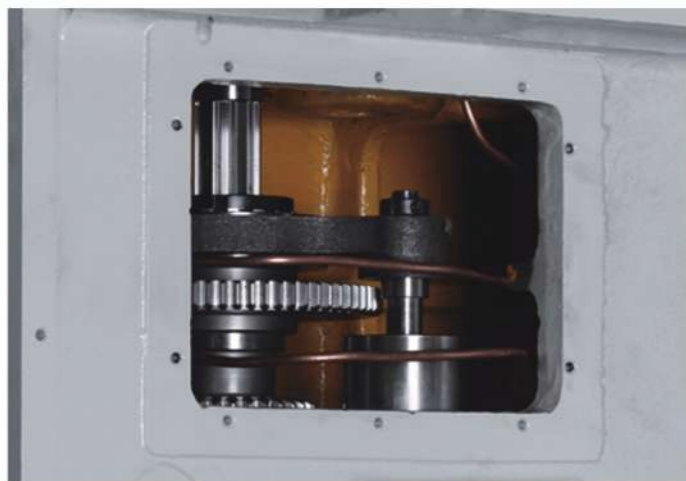

■ **2-Step Gear Box Features**

A spur gear is adopted in the transmission of the spindle in order to increase the efficiency of transmission and to strengthen the rigidity of cutting.

With two step gears installed in head stock. We are able to switch between high and low gear giving the spindle two different

characters. With high speed we get the speed like most standard spindle.

With low speed we get 3 times the milling power compares to standard spindles. Our 2-step gear box spindle has less backlash compared to the ZF type gear boxes. Without a belt to transmit the movement from spindle motor to gear, we are able to solve the problem of backlash from the belt with direct gear to gear transmission.

Furthermore, reliability of the gear transmission designed used within the M-One 2 step gear box increase the life of both the spindle and the gears. By having sensors installed in 3 staged areas, the gears and spindle are both protected from unexpected crashes.

The cooling-compelled recurring devices are equipped in to the main bearing box, transmitted gear, and gear transmission bearing. Hence, the thermal heat is reduced and the accuracy of the spindle is prolonged.



Spindle Features

■ **Built in (High Speed Equipment)**

The M-One built in spindle is the most advanced spindle feature in the M-One series spindle line up. With speeds ranging from 15,000-30,000 rpm providing mirror finishing results to many applications.

■ **Belt Driven (Standard Equipment)**

Standard configuration for the M-one series is a belt driven spindle. The belt driven spindle is the most economic and most frequently used spindle in the world. M-One series can be equipped with belt type spindle from 40 to 50 taper, with speeds at 6000-12000 rpm.

■ **In-Line (Mid Range Equipment)**

The in-line M-One spindle design is an innovative 12,000 to 15,000 rpm, inline, direct-drive spindle that is coupled directly to the motor. This provides super-smooth operation for excellent surface finishes, and reduces operating heat for greater thermal stability.

■ **Bt40 & 50 2-Step Gear Box (Heavy Duty Equipment)**

The M-One geared-head spindle provides increased low-end torque for heavy cutting, while retaining the ability to run up to 6,000, 10,000, 12,000 rpm for high-speed machining. It can be equipped with BT40 or BT50 taper spindles, providing 3x the standard N.m. of torque compared to standard spindles.

Control board Tech Features



■ **4 way swivel control panel**

The M-One model machining center futures the one and only 4 way swivel control panel. By being able to swivel multiple axis, the user can adjust the monitor to the perfect viewing position that the operator desires. The 4-way swivel controller panel is not limited in anyway. This means the swivel controller can be equipped with controllers ranging for Fanuc, Mitsubishi, Siemens, and Heidenhain.



	M-One 6	M-One 8	M-One 10	M-One 11	M-One 20	M-One 40	M-One 60	M-One 80
<b>Worktable</b>								
Worktable Size(mm)	800×460	960×600	1100×600	1200×600	1300×700	1500×700	1700×700	1900×700
Working Range(mm)	650×500	860×600	1020×600	1100×600	1200×600	1400×700	1600×700	1800×700
T-slot(mm)	80×5×18	100×5×18	100×5×18	100×5×18	120×5×18	120×5×18	120×5×18	120×5×20
Max weight on table(kgs)	500	800	1000	1000	1200	1500	1700	2000
<b>Travel</b>								
X/Y/Z-Axis(mm)	650/500/500	860/600/600	1020/600/600	1100/600/600	1200/600/620	1400/700/620	1600/700/620	1800/700/620
Spindle nose to worktable surface(mm)	110-610	150-750	150-750	150-750	110-730	110-730	110-730	110-730
<b>Spindle</b>								
Spindle Tapper	BT/ISO/CAT40	BT/ISO/CAT40	BT/ISO/CAT40	BT/ISO/CAT40	BT/ISO/CAT40	BT/ISO/CAT50	BT/ISO/CAT50	BT/ISO/CAT50
Spindle Speed(rpm)	10000	10000	10000	10000	10000	6000	6000	6000
Drive Type	Belt							
Spindle Motor(kw)	5.5	11	11	11	11	15	15	18.5
<b>Auto exchange system</b>								
Tool quantity(T)	24	24	24	24	24	24	24	24
Changing Type	Bi-Directional, Random							
Tool diameter and length(mm)	φ 80/300mm				φ 112/350mm			
Tool weight(kgs)	8				15			
Tool Type	BT40				BT50			
Tool exchange Time(sec)	T-T: 1.8Sec; C-C: 4Sec				T-T: 3.5Sec; C-C: 7Sec			
<b>X/Y/Z-axis Motor</b>								
X/Y/Z-axis Servo motor(fanuc)	1.8/1.8/3	3/3/3	3/3/3	3/3/3	3/3/3	3/3/3	3/3/3	3/3/3
X/Y/Z-axis Servo motor(Mitsubishi)	1.5/1.5/3	2/2/3	2/2/3	2/2/3	2/2/3	3/3/3	3/3/3	4.5/4.5/4.5
X/Y/Z-axis Cutting feed rate(mm/min)	12000	12000	12000	12000	12000	12000	10000	10000
X/Y/Z-axis rapid feed rate(m/min)	36/36/36	36/36/24	36/36/24	36/36/24	36/36/24	24/24/24 (36)	24/24/24 (36)	24/24/24 (36)
<b>Accuracy</b>								
Positioning(mm)	±0.005	±0.005	±0.005	±0.005	±0.005	±0.005	±0.005	±0.005
Repeatability(mm)	±0.003	±0.003	±0.003	±0.003	±0.003	±0.003	±0.003	±0.003
<b>Others</b>								
Machine weight(kg)	4800	6500	7500	7900	8500	10800	12500	13500

## M-One Series Machine Measurements

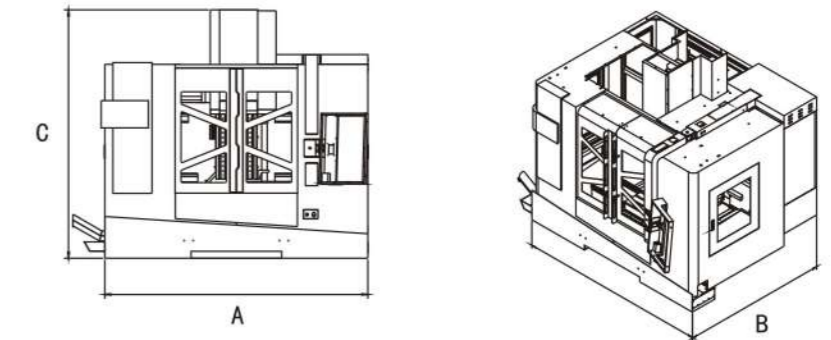

M-One Series	M-One 6	M-One 8	M-One 10	M-One 11	M-One 20	M-One 40	M-One 60	M-One 80
W(A)mm	2250mm	2200mm	2900mm	2900mm	2900mm	3970mm	3970mm	4200mm
L(B)mm	2400mm	2900mm	2500mm	2500mm	2500mm	2600mm	2600mm	2600mm
H(C)mm	2300mm	2400mm	2400mm	2400mm	2600mm	3300mm	3300mm	3300mm

### Standard Equipment

- Air Gun
- Transformer
- Rigid Tapping
- Spindle cooler
- External Hand wheel
- Telescopic covers
- Rs232 Transmission line
- Auto Lubrication System
- LED 3 Color Alarm Light
- Explosion-proof fluorescent Light
- Coolant Back Flush System
- Screw Type Chip Conveyor
- Air Blast
- Coolant System
- Leveling Bolts and Leveling Blocks
- Auto power shutoff System
- Heat Exchanger for Cabinet
- Tool box

### Optional Equipment

- Water Gun
- Tool changer
- 4th Axis
- Scale
- Oil tool
- Direct Spindle
- Auto parts mensuration
- CTS
- Auto Tool mensuration



### Standard color

