



High Performance

Flanged Safety Relief Valves

Series 441

Series 441 Full nozzle

Series XXL

Series 444

Series 458

CATALOG

LESER

The-Safety-Valve.com

Type 441, 442 DIN
Conventional design

Type 441, 442
 DIN

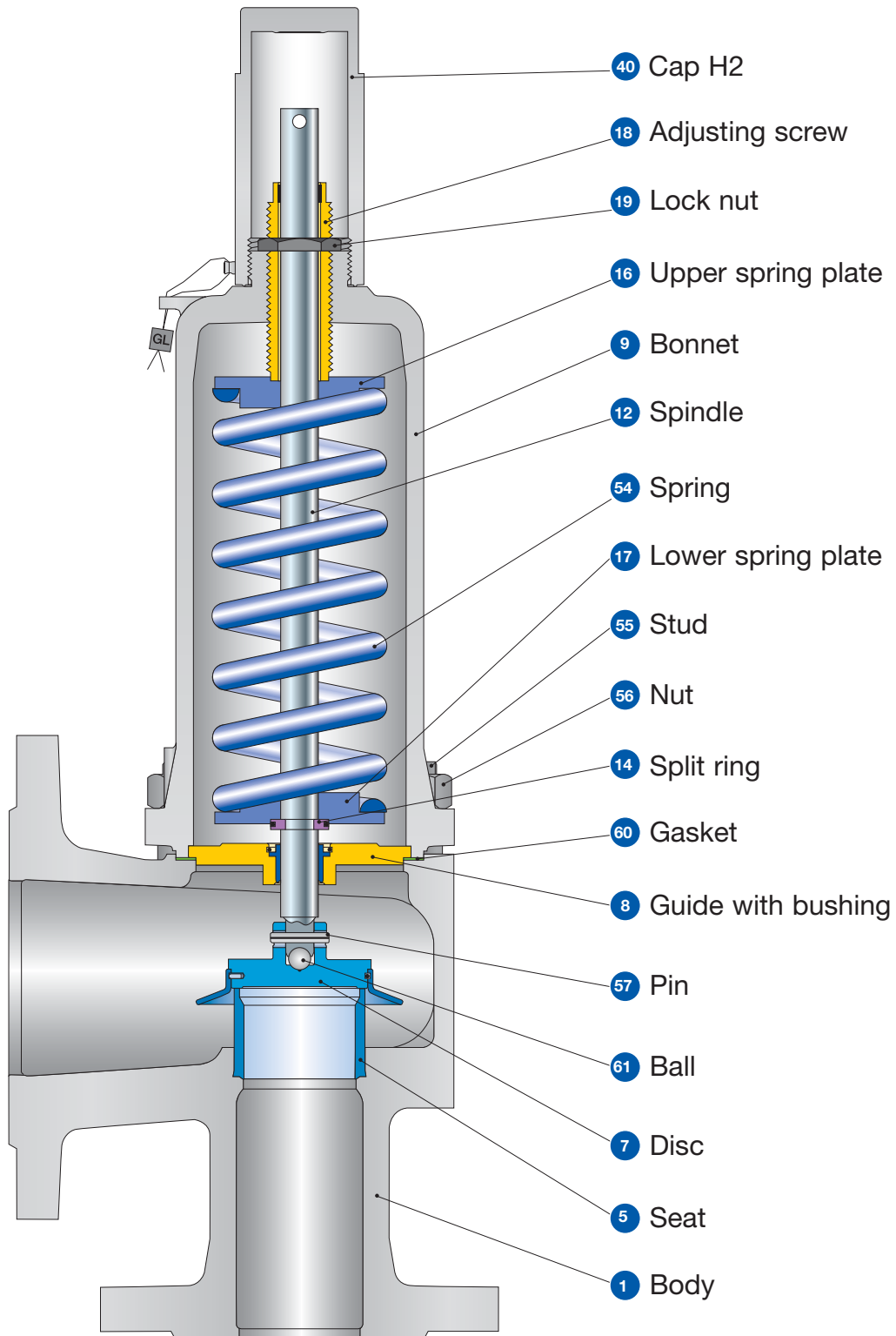

Type 441, 442 DIN

Conventional design

Materials

Item	Component	Type 4411 / 4421 DIN	Type 4415 / 4425 DIN	Type 4412 / 4422 DIN	Type 4414 DIN
1	Body	0.6025	0.7043	1.0619	1.4408
		Cast iron	Ductile Gr. 60-40-18	SA 216 WCB	SA 351 CF8M
5	Seat	1.4404	1.4404	1.4404	1.4404
		316L	316L	316L	316L
7	Disc	1.4122	1.4122	1.4122	1.4404
		Hardened stainless steel	Hardened stainless steel	Hardened stainless steel	316L
8	Guide with bushing	1.4104, 1.0501, 0.7040	1.4104, 1.0501, 0.7040	1.4104, 1.0501, 0.7040	1.4404
		Chrome or carbon steel	Chrome or carbon steel	Chrome or carbon steel	316L
		1.4104 tenifer	1.4104 tenifer	1.4104 tenifer	-
		Chrome steel tenifer	Chrome steel tenifer	Chrome steel tenifer	-
9	Bonnet	0.7040, 0.7043, 1.0619	0.7040, 0.7043, 1.0619	0.7040, 0.7043, 1.0619	1.4408, 1.4404, 1.4571
		Ductile Gr. 60-40-18, SA 216 WCB	Ductile Gr. 60-40-18, SA 216 WCB	Ductile Gr. 60-40-18, SA 216 WCB	SA 351 CF8M, SA 479 316L, SA 479 316Ti
12	Spindle	1.4021	1.4021	1.4021	1.4404
		420	420	420	316L
14	Split ring	1.4104	1.4104	1.4104	1.4404
		Chrome steel	Chrome steel	Chrome steel	316L
16/17	Spring plate	1.0718	1.0718	1.0718	1.4404
		Steel	Steel	Steel	316L
18	Adjusting screw with bushing	1.4104 PTFE	1.4104 PTFE	1.4104 PTFE	1.4404 PTFE
		Chrome steel PTFE	Chrome steel PTFE	Chrome steel PTFE	316L PTFE
19	Lock nut	1.0718	1.0718	1.0718	1.4404
		Steel	Steel	Steel	316L
40	Cap H2	1.0460 or 0.7043	1.0460 or 0.7043	1.0460 or 0.7043	1.4404
		SA 105 or Gr. 60-40-18	SA 105 or Gr. 60-40-18	SA 105 or Gr. 60-40-18	316L
54	Spring standard	1.1200, 1.8159, 1.7102	1.1200, 1.8159, 1.7102	1.1200, 1.8159, 1.7102	1.4310
	Spring optional	Carbon steel	Carbon steel	Carbon steel	Stainless steel
55	Stud	1.4310	1.4310	1.4310	-
		Stainless steel	Stainless steel	Stainless steel	-
56	Nut	1.1181	1.1181	1.1181	1.4401
		Steel	Steel	Steel	B8M
57	Pin	1.0501	1.0501	1.0501	1.4401
		2H	2H	2H	8M
60	Gasket	1.4310	1.4310	1.4310	1.4310
		Stainless steel	Stainless steel	Stainless steel	Stainless steel
61	Ball	Graphite / 1.4401	Graphite / 1.4401	Graphite / 1.4401	Graphite / 1.4401
		Graphite / 316	Graphite / 316	Graphite / 316	Graphite / 316
61	Ball	1.3541	1.3541	1.3541	1.4401
		Hardened stainless steel	Hardened stainless steel	Hardened stainless steel	316

Please notice:

- Modifications reserved by LESER
- If several materials are specified LESER defines the material.
- LESER can upgrade materials without notice.
- Every part can be replaced by other material acc. to customer specification.

Type 441, 442 DIN
Balanced bellows design

Type 441, 442
 DIN

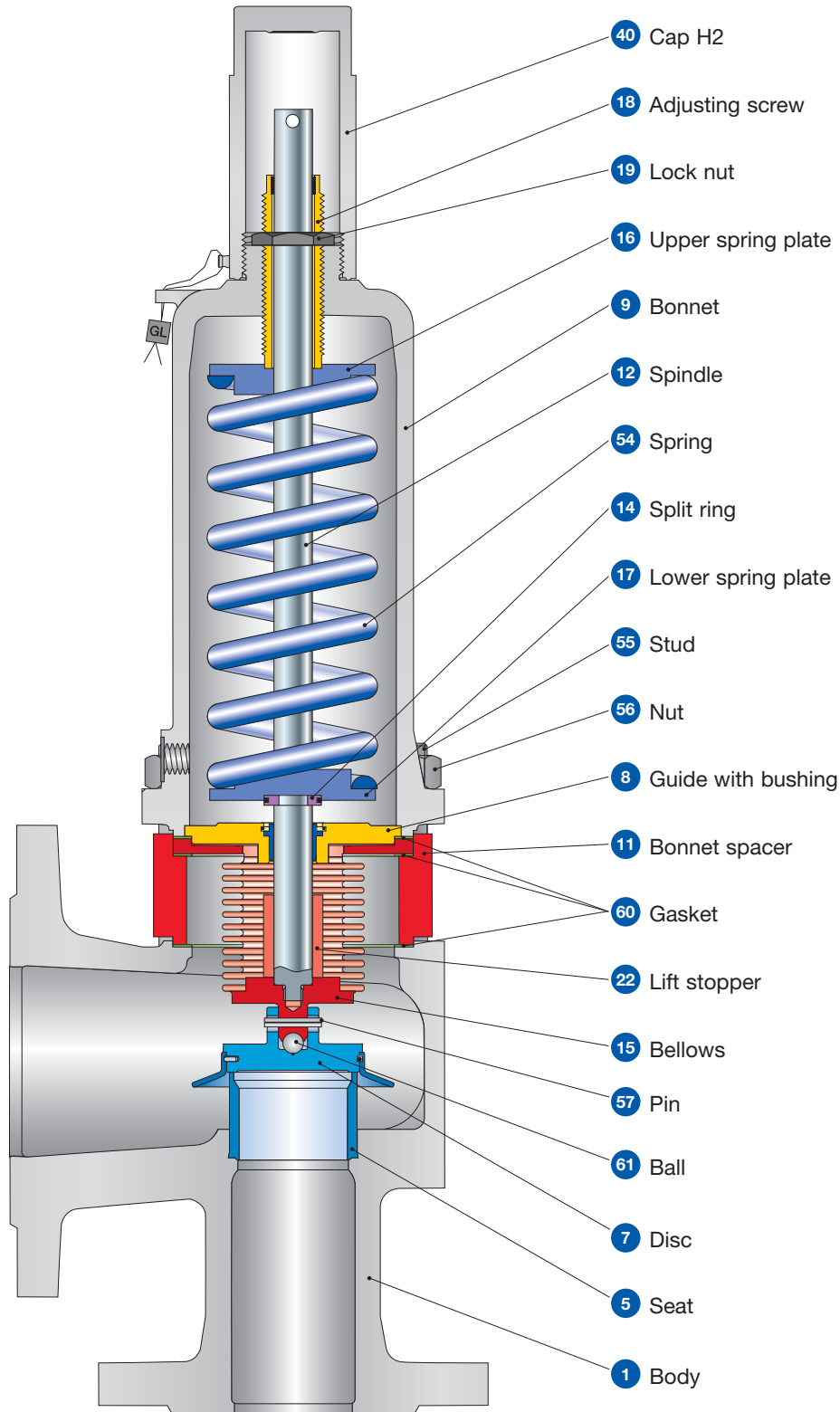

Type 441, 442 DIN

Balanced bellows design

Materials

Item	Component	Type 4411 / 4421 DIN	Type 4415 / 4425 DIN	Type 4412 / 4422 DIN	Type 4414 DIN
1	Body	0.6025	0.7043	1.0619	1.4408
		Cast iron	Ductile Gr. 60-40-18	SA 216 WCB	SA 351 CF8M
5	Seat	1.4404	1.4404	1.4404	1.4404
		316L	316L	316L	316L
7	Disc	1.4122	1.4122	1.4122	1.4404
		Hardened stainless steel	Hardened stainless steel	Hardened stainless steel	316L
8	Guide with bushing	1.4104, 1.0501, 0.7040	1.4104, 1.0501, 0.7040	1.4104, 1.0501, 0.7040	1.4404
		Chrome or carbon steel	Chrome or carbon steel	Chrome or carbon steel	316L
		1.4104 tenifer	1.4104 tenifer	1.4104 tenifer	-
		Chrome steel tenifer	Chrome steel tenifer	Chrome steel tenifer	-
9	Bonnet	0.7040, 0.7043, 1.0619	0.7040, 0.7043, 1.0619	0.7040, 0.7043, 1.0619	1.4408, 1.4404, 1.4571
		Ductile Gr. 60-40-18, SA 216 WCB	Ductile Gr. 60-40-18, SA 216 WCB	Ductile Gr. 60-40-18, SA 216 WCB	SA 351 CF8M, SA 479 316L, SA 479 316Ti
11	Bonnet spacer	1.0460	1.0460	1.0460	1.4404
		Carbon steel	Carbon steel	Carbon steel	316L
12	Spindle	1.4404	1.4404	1.4404	1.4404
		316L	316L	316L	316L
14	Split ring	1.4104	1.4104	1.4104	1.4404
		Chrome steel	Chrome steel	Chrome steel	316L
15	Bellows	1.4571	1.4571	1.4571	1.4571
		316Ti	316Ti	316Ti	316Ti
16/17	Spring plate	1.0718	1.0718	1.0718	1.4404
		Steel	Steel	Steel	316L
18	Adjusting screw with bushing	1.4104 PTFE	1.4104 PTFE	1.4104 PTFE	1.4404 PTFE
		Chrome steel PTFE	Chrome steel PTFE	Chrome steel PTFE	316L PTFE
19	Lock nut	1.0718	1.0718	1.0718	1.4404
		Steel	Steel	Steel	316L
22	Lift stopper	1.4404	1.4404	1.4404	1.4404
		316L	316L	316L	316L
40	Cap H2	1.0460 or 0.7043	1.0460 or 0.7043	1.0460 or 0.7043	1.4404
		SA 105 or Gr. 60-40-18	SA 105 or Gr. 60-40-18	SA 105 or Gr. 60-40-18	316L
54	Spring standard	1.1200, 1.8159, 1.7102	1.1200, 1.8159, 1.7102	1.1200, 1.8159, 1.7102	1.4310
		Carbon steel	Carbon steel	Carbon steel	Stainless steel
	Spring optional	1.4310	1.4310	1.4310	-
55	Stud	1.4401	1.4401	1.4401	1.4401
		B8M	B8M	B8M	B8M
56	Nut	1.4401	1.4401	1.4401	1.4401
		8M	8M	8M	8M
57	Pin	1.4310	1.4310	1.4310	1.4310
		Stainless steel	Stainless steel	Stainless steel	Stainless steel
60	Gasket	Graphite / 1.4401	Graphite / 1.4401	Graphite / 1.4401	Graphite / 1.4401
		Graphite / 316	Graphite / 316	Graphite / 316	Graphite / 316
61	Ball	1.3541	1.3541	1.3541	1.4401
		Hardened stainless steel	Hardened stainless steel	Hardened stainless steel	316

Please notice:

- Modifications reserved by LESER
- If several materials are specified LESER defines the material.
- LESER can upgrade materials without notice.
- Every part can be replaced by other material acc. to customer specification.

Type 441, 442 DIN

Article numbers

Type 441, 442
DIN

	DN _i	20	20	25	32	40	50	65	80	100	125	150	200	
	DN _o	32	40	40	50	65	80	100	125	150	200	250	300	
	Actual Orifice diameter d _o [mm]	18	18	23	29	37	46	60	74	92	98	125	165	
	Actual Orifice area A _o [mm ²]	254	254	416	661	1075	1662	2827	4301	6648	7543	12272	21382	
Body material: 0.6025 (cast iron)														
Bonnet closed	H2	Art. No. 4411.	4372	-	4382	4392	4402	4412	4422	4432	4442	4452	4462	-
	H3	Art. No. 4411.	4373	-	4383	4393	4403	4413	4423	4433	4443	4453	-	-
	H4	Art. No. 4411.	4374	-	4384	4394	4404	4414	4424	4434	4444	4454	4464	-
open	H3	Art. No. 4421.	4375	-	4385	4395	4405	4415	4425	4435	4445	4455	4465	-
Body material: 0.7043 (ductile Gr. 60-40-18)														
Bonnet closed	H2	Art. No. 4415.	-	-	7382	7392	7402	7412	7422	7432	7442	7452	7462	7472
	H3	Art. No. 4415.	-	-	7383	7393	7403	7413	7423	7433	7443	7453	-	-
	H4	Art. No. 4415.	-	-	7384	7394	7404	7414	7424	7434	7444	7454	7464	7474
open	H3	Art. No. 4425.	-	-	7385	7395	7405	7415	7425	7435	7445	7455	7465	7475
Body material: 1.0619 (WCB)														
Bonnet closed	H2	Art. No. 4412.	-	4502	4512	4522	4532	4542	4552	4562	4572	4582	4592	4612
	H3	Art. No. 4412.	-	4503	4513	4523	4533	4543	4553	4563	4573	4583	-	-
	H4	Art. No. 4412.	-	4504	4514	4524	4534	4544	4554	4564	4574	4584	4594	4614
open	H3	Art. No. 4422.	-	4505	4515	4525	4535	4545	4555	4565	4575	4585	4595	4615
Body material: 1.4408 (CF8M)														
Bonnet closed	H2	Art. No. 4414.	-	-	4642	4652	4662	4672	4682	4692	4702	4712	4722	-
	H4	Art. No. 4414.	-	-	4644	4654	4664	4674	4684	4694	4704	4714	4724	-

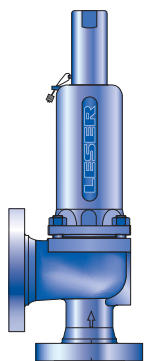

Type 441
Cap H2
Closed bonnet
Conventional design

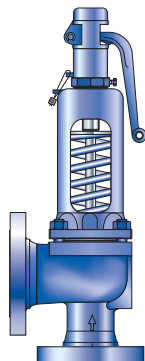

Type 442
Plain lever H3
Open bonnet
Conventional design

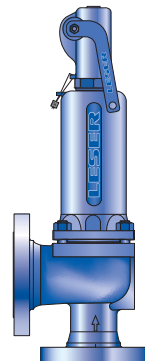

Type 441
Packed lever H4
Closed bonnet
Conventional design

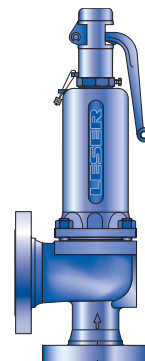

Type 441
Plain lever H3
Closed bonnet
Conventional design

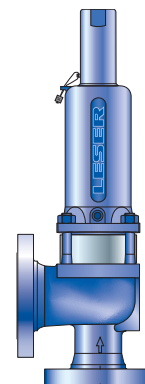

Type 441
Cap H2
Closed bonnet
Balanced bellows design

Type 441, 442 DIN

Dimensions and weights

Metric Units

	DN _i	20	20	25	32	40	50	65	80	100	125	150	200
	DN _o	32	40	40	50	65	80	100	125	150	200	250	300
	Actual Orifice diameter d _o [mm]	18	18	23	29	37	46	60	74	92	98	125	165
	Actual Orifice area A _o [mm ²]	254	254	416	661	1075	1662	2827	4301	6648	7543	12272	21382
Weight		9	9	9	12	16	22	32	56	75	85	131	285
[kg]	with bellows	9,4	9,4	10	13	17	24	36	60	83	93	142	289
Center to face	Inlet a	85	85	105	115	140	150	170	195	220	250	285	290
[mm]	Outlet b	95	95	100	110	115	120	140	160	180	200	225	300
Height (H4)	Standard H max.	304	304	339	446	512	569	699	801	883	913	1083	1380
[mm]	Bellows H max.	337	337	378	488	550	615	769	860	939	969	1141	1380
Support brackets	A									277	277	320	490
[mm]	B									160	160	185	¹⁾
(drilled only on request, Option code H42)	C									Ø 18	Ø 18	Ø 18	Ø 18
	D									293	318	392	¹⁾
	E									21	21	28	¹⁾

Body material: 0.6025 (cast iron)

DIN Flange²⁾	Inlet	PN 16	-										PN 16
	Outlet	PN 16	-										PN 16

Body material: 0.7043 (ductile Gr. 60-40-18)

DIN Flange²⁾	Inlet	-	-					PN 40				PN 16	PN 25
	Outlet	-	-							PN 16			PN 10

Body material: 1.0619 (WCB)

DIN Flange²⁾	Inlet	-	-							PN 40			PN 25
	Outlet	-	-							PN 16			

Body material: 1.4408 (CF8M)

DIN Flange²⁾	Inlet	-	-										PN 40
	Outlet	-	-										PN 16

1)

Body material	B	D	E
	[mm]	[mm]	[mm]
0.6025	150	290	16
0.7043	150	489	25
1.0619	160	489	25
1.4408	150	489	25

2) Standard flange rating. For other flange drillings and facings please refer to page 19.

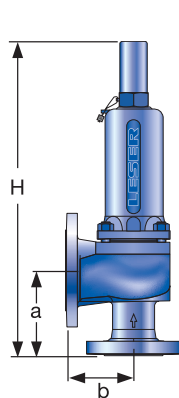

Conventional design

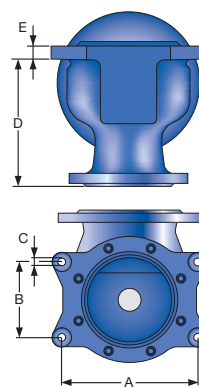

Support brackets

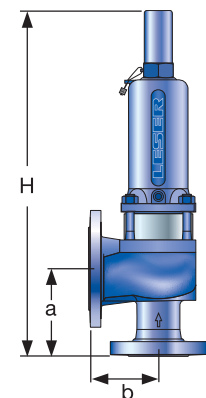

Balanced bellows design

Type 441, 442 DIN

Pressure temperature ratings

Metric Units

	DN _i	20	20	25	32	40	50	65	80	100	125	150	200
	DN _o	32	40	40	50	65	80	100	125	150	200	250	300
	Actual Orifice diameter d _o [mm]	18	18	23	29	37	46	60	74	92	98	125	165
	Actual Orifice area A _o [mm ²]	254	254	416	661	1075	1662	2827	4301	6648	7543	12272	21382

Body material: 0.6025 (cast iron)

DIN Flange	Inlet	PN 16	-	PN 16										-
	Outlet	PN 16	-	PN 16										-
Minimum set pressure	p [bar _g] S/G/L	0.1	-	0.1	0.1	0.1	0.1	0.1	0.1	0.1	0.1	0.1	-	
Min. set pressure¹⁾ standard bellows	p [bar _g] S/G/L	3	-	3	3	3	3	3	3	2.74	2.01	0.2	-	
Min. set pressure low press. bellows	p [bar _g] S/G/L	2.00	-	0.98	1.41	1.11	1.81	1.50	1.05	1.18	1.41	-	-	
Maximum set pressure	p [bar _g] S/G/L	16	-	16	16	16	16	16	16	16	16	16	-	
Max. set pressure with special spring	p [bar _g] S/G/L	16	-	16	16	16	16	16	16	16	16	16	-	
Temperature acc. to DIN EN	min. [°C]	-10	-	-10										-
	max. [°C]	+300	-	+300										-
Temperature acc. to ASME	min. [°C]	-	-	-										-
	max. [°C]	-	-	-										-

Body material: 0.7043 (ductile Gr. 60-40-18)

DIN Flange	Inlet	-	-	PN 40								PN 16	PN 25	
	Outlet	-	-	PN 16								PN 10	PN 10	
Minimum set pressure	p [bar _g] S/G/L	-	-	0.1	0.1	0.1	0.1	0.1	0.1	0.1	0.1	0.1	0.1	
Min. set pressure¹⁾ standard bellows	p [bar _g] S/G/L	-	-	3	3	3	3	3	3	2.74	2.01	0.2	0.2	
Min. set pressure low press. bellows	p [bar _g] S/G/L	-	-	0.98	1.41	1.11	1.81	1.50	1.05	1.18	1.41	-	-	
Maximum set pressure	p [bar _g] S/G/L	-	-	40	40	40	40	40	32	40	16	16	20	
Max. set pressure with special spring	p [bar _g] S/G/L	-	-	40	40	40	40	40	40	40	16	16	25	
Temperature acc. to DIN EN	min. [°C]	-	-	-60										-
	max. [°C]	-	-	+350										-
Temperature acc. to ASME	min. [°C]	-	-	-10										-
	max. [°C]	-	-	+350										-

¹⁾ Min. set pressure standard bellows = Max. set pressure low pressure bellows.

Type 441, 442 DIN

Pressure temperature ratings

Metric Units

DN _i	20	20	25	32	40	50	65	80	100	125	150	200
DN _o	32	40	40	50	65	80	100	125	150	200	250	300
Actual Orifice diameter d _o [mm]	18	18	23	29	37	46	60	74	92	98	125	165
Actual Orifice area A _o [mm ²]	254	254	416	661	1075	1662	2827	4301	6648	7543	12272	21382

Body material: 1.0619 (WCB)

DIN Flange		Inlet	PN 40										PN 25	
			PN 16											
Minimum set pressure	p [bar _g]	S/G/L	-	0.1	0.1	0.1	0.1	0.1	0.1	0.1	0.1	0.1	0.1	0.1
Min. set pressure¹⁾ standard bellows	p [bar _g]	S/G/L	-	3	3	3	3	3	3	2.74	2.01	0.2	0.2	
Min. set pressure low press. bellows	p [bar _g]	S/G/L	-	2.00	0.98	1.41	1.11	1.81	1.50	1.05	1.18	1.41	-	-
Maximum set pressure	p [bar _g]	S/G/L	-	40	40	40	40	40	40	32	40	28	17	20
Max. set pressure with special spring	p [bar _g]	S/G/L	-	40	40	40	40	40	40	40	40	28	25	25
Temperature²⁾ acc. to DIN EN	min. [°C]	-	-85											
	max. [°C]	-	+450											
Temperature²⁾ acc. to ASME	min. [°C]	-	-29											
	max. [°C]	-	+427											

Body material: 1.4408 (CF8M)

DIN Flange		Inlet	PN 40										-	
			PN 16											
Minimum set pressure	p [bar _g]	S/G/L	-	-	0.1	0.1	0.1	0.1	0.1	0.1	0.1	0.1	0.1	-
Min. set pressure¹⁾ standard bellows	p [bar _g]	S/G/L	-	-	3	3	3	3	3	3	2.74	2.01	0.2	-
Min. set pressure low press. bellows	p [bar _g]	S/G/L	-	-	0.98	1.41	1.11	1.81	1.50	1.05	1.18	1.41	-	-
Maximum set pressure	p [bar _g]	S/G/L	-	-	40	40	40	33	28	13.6	20	17.7	7	-
Max. set pressure with special spring	p [bar _g]	S/G/L	-	-	40	40	40	37	28	25	26	24	10	-
Temperature²⁾ acc. to DIN EN	min. [°C]	-	-	-270										
	max. [°C]	-	-	+400										
Temperature²⁾ acc. to ASME	min. [°C]	-	-	-268										
	max. [°C]	-	-	+538										

¹⁾ Min. set pressure standard bellows = Max. set pressure low pressure bellows.

²⁾ Between -10 °C and lowest temperature indicated „AD 2000-Merkblatt“ W10 shall be taken into account.

Type 441, 442 DIN

Flange drillings

	DN _i	20	20	25	32	40	50	65	80	100	125	150	200	
	DN _o	32	40	40	50	65	80	100	125	150	200	250	300	
	Valve size	–	3/4" x 1 1/2"	1" x 1 1/2"	1 1/4" x 2"	1 1/2" x 2 1/2"	2" x 3"	2 1/2" x 4"	3" x 5"	4" x 6"	5" x 8"	6" x 10"	8" x 12"	
	Actual Orifice diameter d _o [mm]	18	18	23	29	37	46	60	74	92	98	125	165	
	Actual Orifice area A _o [mm ²]	254	254	416	661	1075	1662	2827	4301	6648	7543	12272	21382	
Body material: 0.6025 (cast iron)														
Inlet	DIN EN 1092	PN 10	*	*	*	*	*	*	*	*	*	*	*	
		PN 16	*	*	*	*	*	*	*	*	*	*	*	
		PN 25	–	–	–	–	–	–	–	–	–	–	–	
		PN 40	–	–	–	–	–	–	–	–	–	–	–	
Outlet	DIN EN 1092	PN 10	*	*	*	*	*	*	*	*	H50	H50		
		PN 16	*	*	*	*	*	*	*	*	*	*	*	
		PN 25	–	–	–	–	–	–	–	–	–	–	–	
		PN 40	–	–	–	–	–	–	–	–	–	–	–	
Body material: 0.7043 (ductile Gr. 60-40-18)														
Inlet	DIN EN 1092	PN 10		*	*	*	*	H45	*	H45	*	*	H44	
		PN 16		*	*	*	*	*	*	*	*	*	H45	
		PN 25		*	*	*	*	*	*	*	*	–	–	*
		PN 40		*	*	*	*	*	*	*	*	–	–	–
Outlet	DIN EN 1092	PN 10		*	*	*	*	*	*	*	H50	H50	*	
		PN 16		*	*	*	*	*	*	*	*	*	(H51)	
		PN 25		*	(*)	(H15)	(*)	–	–	–	–	–	–	
		PN 40		*	(*)	(H15)	(*)	–	–	–	–	–	–	
Body material: 1.0619 (WCB), 1.4408 (CF8M)														
Inlet	DIN EN 1092	PN 10	*	*	*	*	*	H45	H45	H45	H45	H45	H44	
		PN 16	*	*	*	*	*	H45	H45	H45	H45	H45	H44	
		PN 25	*	*	*	*	*	*	*	*	*	*	*	
		PN 40	*	*	*	*	*	*	*	*	*	*	*	
	ASME B16.5 ¹⁾	CL150	H64	H64	H64	H64	H64	H64	H64	H64	[H64]	H64	H64	H64
		CL300	–	–	H65	–	[H65]	–	–	–	–	–	–	–
Outlet	DIN EN 1092	PN 10	*	*	*	*	*	*	*	*	H50	H50	H50	
		PN 16	*	*	*	*	*	*	*	*	*	*	*	
		PN 25	*	*	*	(H15)	(*)	–	–	–	–	–	H52	
		PN 40	*	*	*	(H15)	(*)	–	–	–	–	–	H52	
	ASME B16.5 ¹⁾	CL150	H79	H79	H79	H79	H79	[H79]	H79	H79	H79	H79	H79	H79
		CL300	–	–	[H80]	–	–	–	–	–	–	–	–	–

Note: Flange drillings and facings meet always the requirements of mentioned flange standards.
Flange thickness and outer diameter may vary from flange standard.

¹⁾For flange drillings acc. to ASME B16.5 please use preferred Type 441, 442 ANSI.

Type 441, 442 DIN

Flange facings

 Type 441, 442
DIN

Indication	Norm	Inlet	Outlet	Remark
General				
Flange undrilled	–	H38	H39	
Linde-V-Nut, Form V48	Linde Standard 420-08	J07	J08	Groove: Rz 16
Linde-V-Nut, Form V48A	LDeS 3313.36	J05	J06	Groove: Rz 4, e.g. with hydrogen
Lens seal form L (without sealing lens)	DIN 2696 LDeS 3313.35	J11	J12	

Acc. to DIN EN 1092				
		Inlet	Outlet	Remark
Flange facing (see LDeS 3313.40)		PN 10 – PN 40	PN 10 – PN 40	Rz-data according to DIN EN 1092 in µm
Raised face	Type B1	*	*	Facing: Rz = 12.5 – 50
	Type B2	L36	L38	Facing: Rz = 3.2 – 12.5
Tongue face C ¹⁾		H94	H92	Steel flange only
Groove face D ¹⁾		H93	H91	
Male face E		H96	H98	
Female face F		H97	H99	
O-ring male face G		J01	J02	
O-ring female face H		J03	J04	

Acc. to ASME B16.5										
Body material	Inlet	Outlet	Smooth finish ²⁾		Serrated finish		RTJ-groove			
			Inlet	Outlet	Inlet	Outlet	Inlet		Outlet	
			Option code		Option code		RTJ- Class	Option code	RTJ- Class	Option code
1.0619, 1.4408	all	all	L52	L53	*	*	CL150	H62	CL150	H63

¹⁾ LESER manufactures the groove at flanged valves by milling. If a customer demands a turned surface in the soil of the groove according to DIN EN 1092-1 an additional option code is necessary: "S01: soil of the groove drilled".

²⁾ Smooth finish is not defined in the effective standards.

Note: Flange drillings and facings meet always the requirements of mentioned flange standards.
Flange thickness and outer diameter may vary from flange standard.

Change of nominal diameter with welding flange

Designation	Material	DN / NPS		
Type 441 DIN		32	40	80
Change nominal diameter inlet to DN 40 / NPS 1½"	1.0619 (WCB)	I28	–	–
	1.4408 (CF8M)	I28	–	–
Change nominal diameter outlet to DN 80 / NPS 3"	1.0619 (WCB)	–	I29	–
	1.4408 (CF8M)	–	I29	–
Change nominal diameter outlet to DN 150 / NPS 6"	1.0619 (WCB)	–	–	I30
	1.4408 (CF8M)	–	–	I30