

**Dimensions explosion proof version**

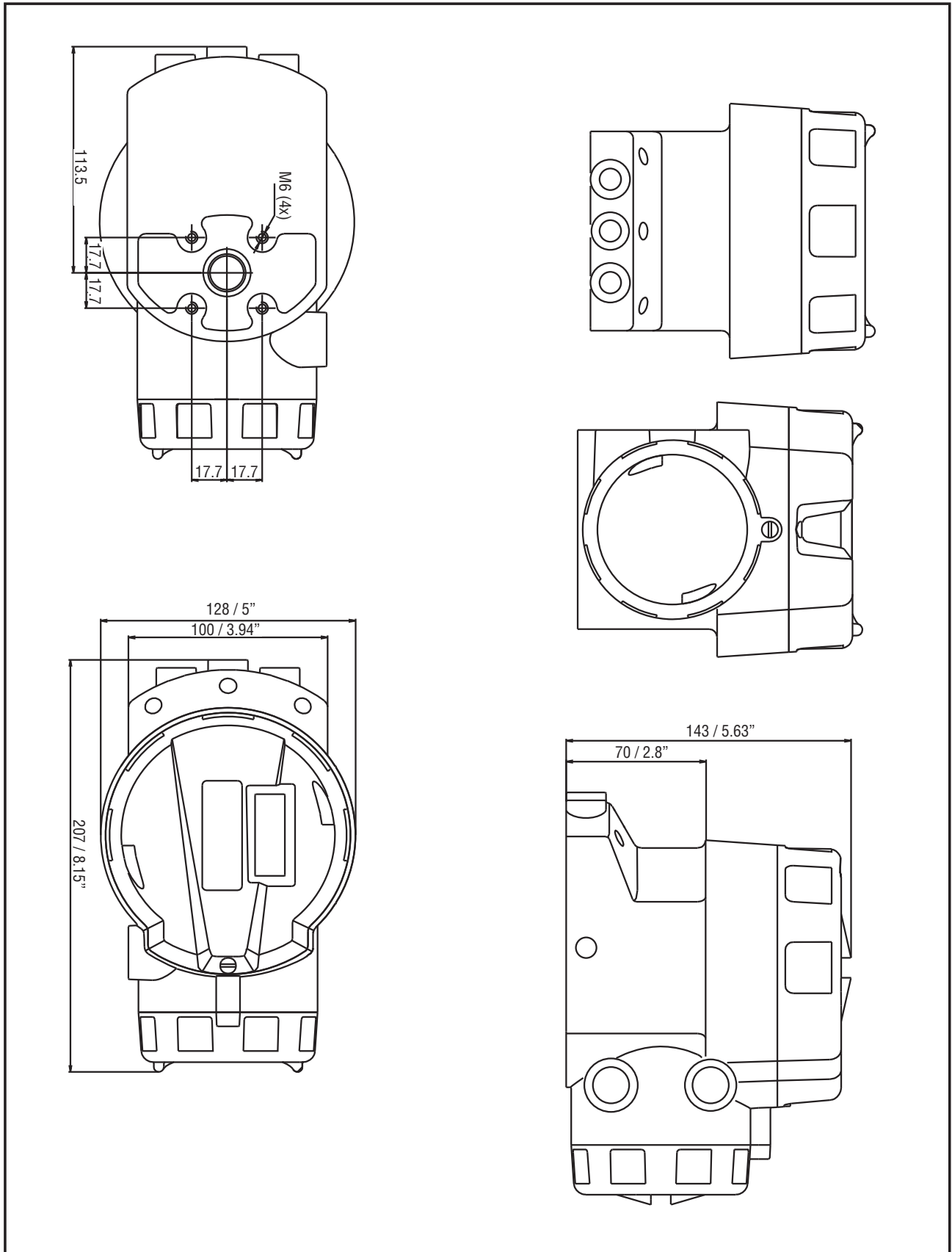

## 12. Spare parts

---

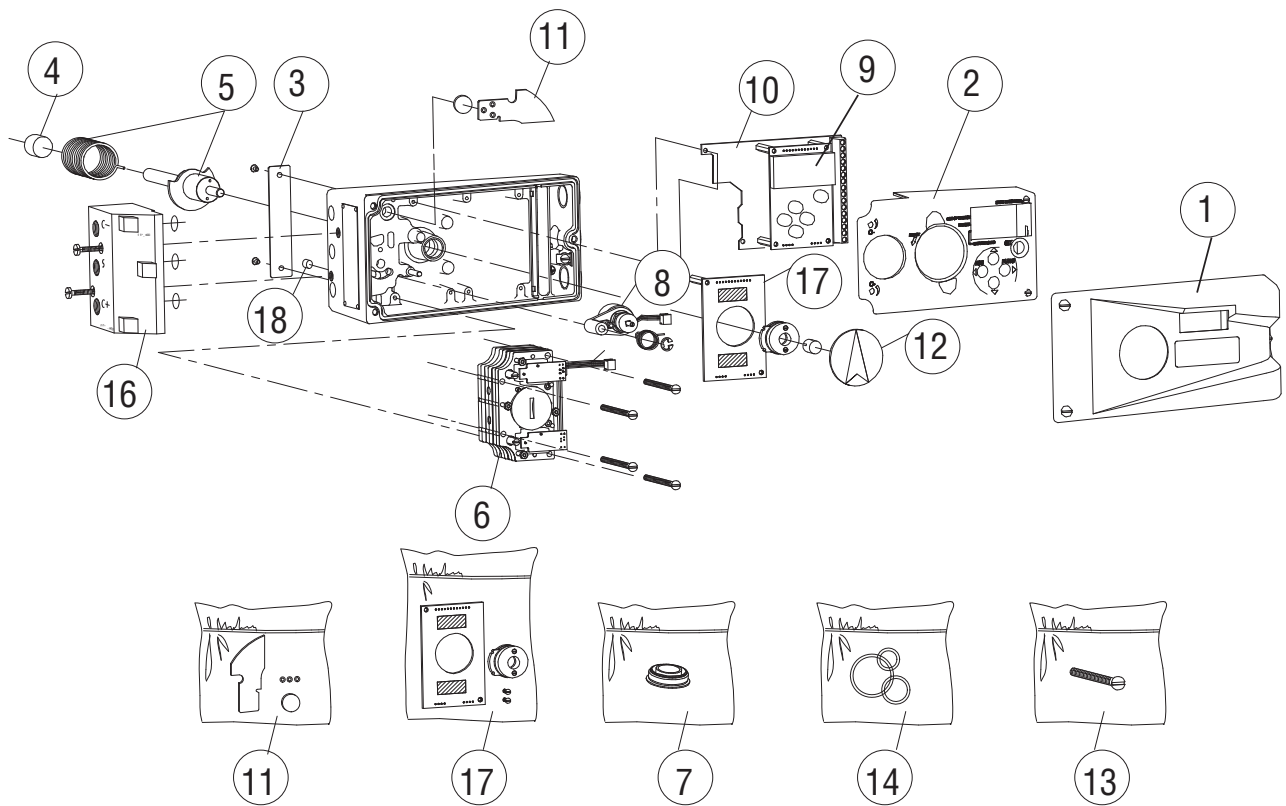

## General Purpose and Intrinsically Safe housing

No	Part no	Description
1	D3-SP6	Black cover incl. screws
2	D3-SP11	Internal cover incl. screws
3	P3-SP13	Cover plate incl. screw
4	3-SXX	Spindle adaptor (XX = 01, 02, 06, 26, 30, 36, 40, 41)
5	3-AS23	S23 Shaft complete incl. gearwheel, friction clutch, spring
5	3-AS39	S39 Shaft complete incl. gearwheel, friction clutch, spring
5	3-AS09	S09 Shaft complete incl. gearwheel, friction clutch, spring
6	D3-SP1	Block complete, incl. cable, rubber seal, filter plug
6	D3-SP1-PS	Block complete, Pressure sensors, incl. cable, seal, filter plug
6	D3-SP1-FF	Block complete, incl. cable, rubber seal, filter plug, Fail Freeze
6	D3-SP1-PFF	Block complete, Pressure sensors, incl. cable, rubber seal, filter plug, Fail Freeze
7	D3-SP9	Filter plug, incl. O-ring, filter
8	3-SP8B	Potentiometer complete incl. spring, holder, cable
9	3-SP37HR	PCB LCD Display assembly Hi Res type
10	D3-SP35P	PCBs (Terminal and processor) Profibus
10	3-SP80X	PCB Motherboard
10	3-SP80H	PCB Motherboard HART
11	3-SP84	Pressure sensor PCB assembly complete
12	3-SP48A	Indicator arrow assembly
13	D3-SP/SCREW	Kit, bag with screws
14	D3-SP/SEAL	Kit, bag with O-rings, seals
16	D3-SP34G	Gauge block G, complete
16	D3-SP34N	Gauge block NPT, complete
17	3-AS81T	PCB Transmitter 4-20mA assembly
17	3-AS81M	PCB Transmitter and Mechanical switches, assembly
17	3-AS81N	PCB Transmitter and Namur sensors, assembly
17	3-AS81P	PCB Transmitter and Proximity switches, assembly
17	3-AS81N4	PCB Transmitter, slot type Namur sensors (P+F SJ2 S1N), assembly
17	3-AS81N5	PCB Transmitter, slot type Namur sensors (P+F SJ2 SN), assembly
17	3-AS81N6	PCB Transmitter, slot type Namur sensors (P+F SJ2N), assembly
18	D3-67	Silencer, Sintered brass
	D3-SP/REPAIR KIT	Kit containing membranes and gasket for the air block and the O-ring for the filter plug cap.

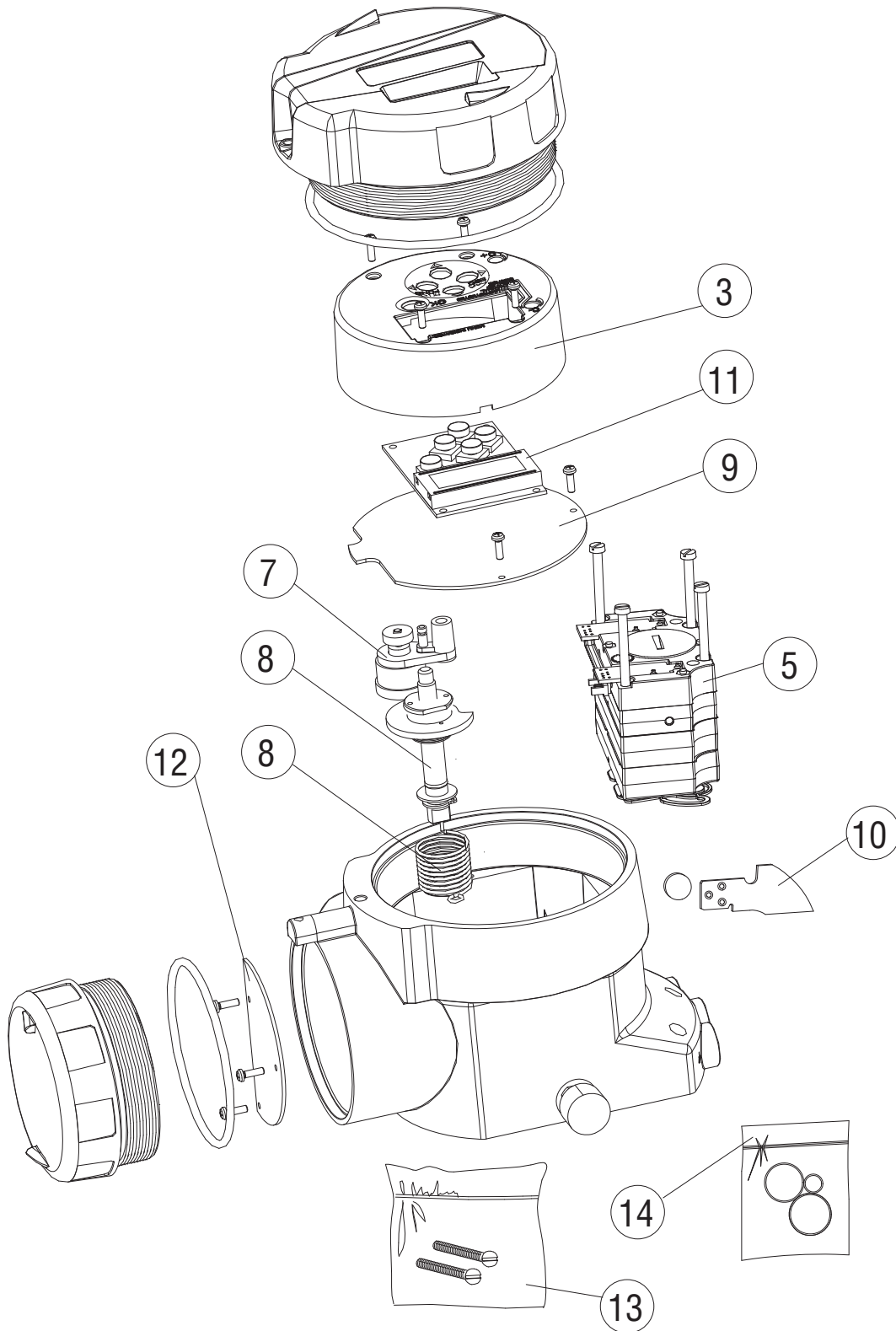

## Explosion Proof housing

No	Part no	Description
3	D3E-SP4	Internal cover incl. screws
5	D3-SP1	See D3 page 53
5	D3-SP1-PS	See D3 page 53
7	3E-SP8	Potentiometer complete incl. spring, holder, cable
8	3-AS23	S23 Shaft complete incl. gearwheel, friction clutch, spring
8	3-AS39	S39 Shaft complete incl. gearwheel, friction clutch, spring
8	3-AS09	S09 Shaft complete incl. gearwheel, friction clutch, spring
9	3E-SP80X	PCB Mother board
9	3E-SP80XT	PCB Mother board, 4-20mA transmitter
9	3E-SP80H	PCB Mother board HART
9	3E-SP80HT	PCB Mother board, HART 4-20mA transmitter
10	3-SP84	See D3 page 53
11	3-SP37HR	See D3 page 53
12	3E-SP83	PCB Terminals
13	D3E-SP/SCREW	Kit, bag with screws
14	D3E-SP/SEAL	Kit, bag with O-rings, seals