

YS-305RPD Automatic STRAPPING MACHINE

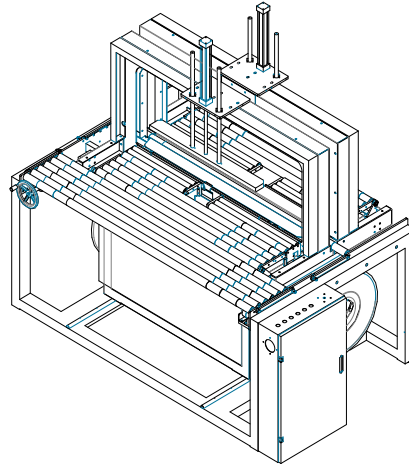

1. Power Supply: AC220V, 50/60Hz, 2.4kW
2. Machine Dimension (mm): L2040mm×W1190mm×H2100mm
Strap: Minimum package size 80mm(W)×60mm(H)
Standard Size: 1250mm(W) X 500mm(H), inner size
3. Table Height: 850mm
4. Weight Capability: 80kg
5. Packing Speed: ≤30 package/min
6. Tension Force: 0-45kg
7. Applicable PP Strap: PP, width 5mm, thickness 0.5mm~0.8mm
8. Applicable PP Strap Spool: width: 170mm~190mm
Inner Dia.: 200mm~210mm, outer dia.: 400mm~450mm
9. Welt way: heat fusion method, bottom welt, welt area ≥90%, welt position tolerance ≤2mm。
10. Machine weight: 380kg
11. Electrical Configuration
PLC control: YOUNGSUN
Middle Relay: French “Schneider”
Motor: MEIWA, MCN
Sensor Switch and Proximity Switch: German “P+F”, Japanese “OMRON”, or other famous brand.
12. Noise: working condition, Noise ≤75dB (A)
13. Environmental conditions: humidity ≤90%, temperature 0-40°C

LX-500 fully automatic CORRUGATED BUNDLE SQUARING

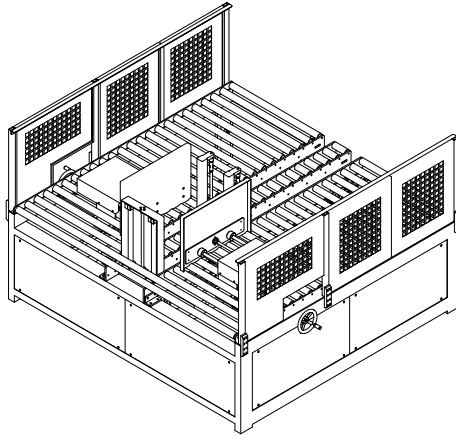

1. Power Supply: AC380V, 50/60Hz, 1.0kW
2. Air Pressure: 0.6MPa
3. Dimension (mm): L1900mm×W2050mm×H1470mm
4. Table Height: 850mm
5. Weight Capability: 80kg
6. Transport Speed: 15 package/min
7. Applicable Package Size (mm): L (250~1100) mm×W (320~1200) mm×H (0~450) mm
8. Electrical Configuration:
 - PLC control: YOUNGSUN
 - Middle Relay: French “Schneider”
 - Frequency Converter: French “Schneider
 - Motor: MEIWA
 - Cylinder: Taiwan ”AIRTAC
 - Sensor Switch and Proximity Switch: German “P+F” ,Japanese “OMRON”,
 - or other famous brand.
9. Noise: working condition, Noise≤75dB (A)
10. Environmental conditions: humidity≤90%, temperature0-40°C