

Platform lowlifter truck 2.0 ton

BT levio

B-series

LPE200B



Battery dependent dimensions

Dimensions	Battery change		Lift out
	Compartment	Small	
1.9 Wheelbase, fork raised/lowered	y	mm	1362/1406
4.19 Overall length with platform up/down	l_1	mm	1816/2266
4.20 Length to face of forks with platform up/down	l_2	mm	666/1116
4.33 Aisle width for pallets 1000x1200 crossways with platform up/down	A_1	mm	2430/2894
4.34 Aisle width for pallets 800x1200 lengthways with platform up/down	A_x	mm	2277/2741
4.35 Turning radius, fork raised with platform up/down	W_a	mm	1585/2049
6.4 Battery voltage, nominal capacity K_3		V/Ah	24/225-300
6.5 Battery weight		kg	210-285

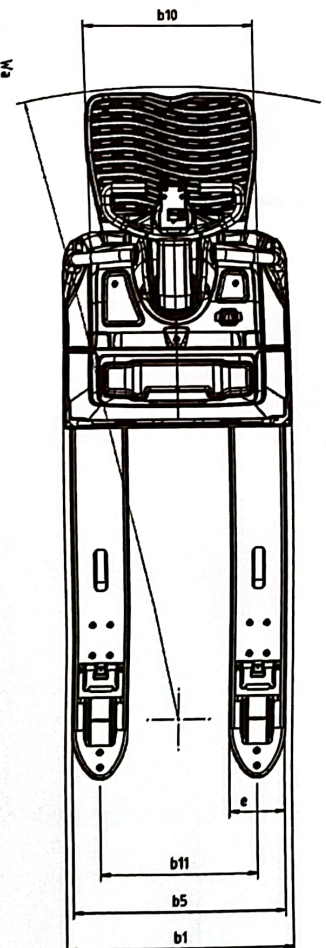
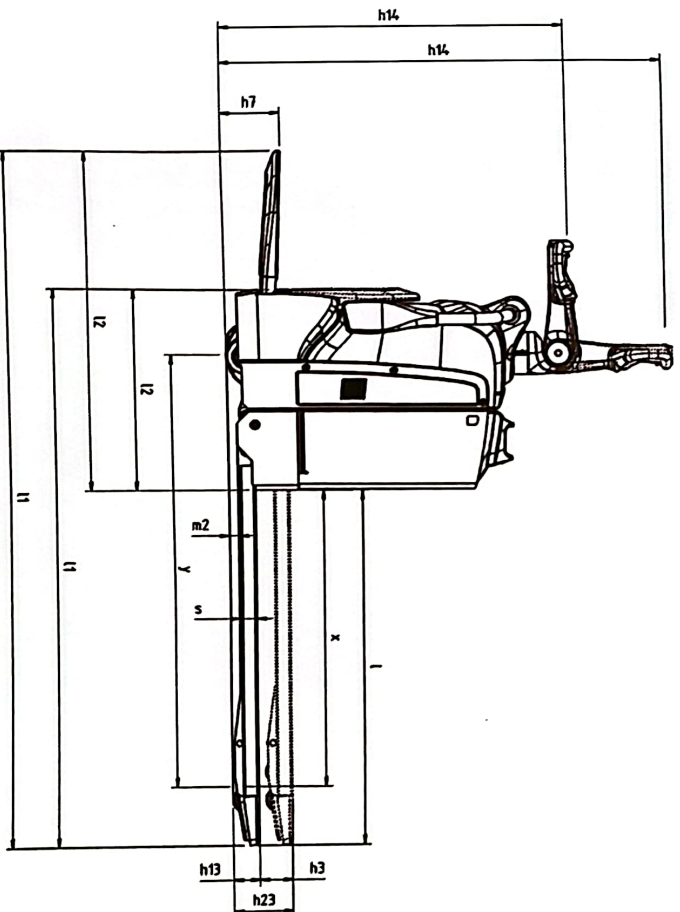

Truck features:

- Fingertip controls
- Information display
- Electronic braking system
- Electronic regenerative brakes
- Driver detection system
- Ergonomic platform
- E-bar (option)
- Foldable gates

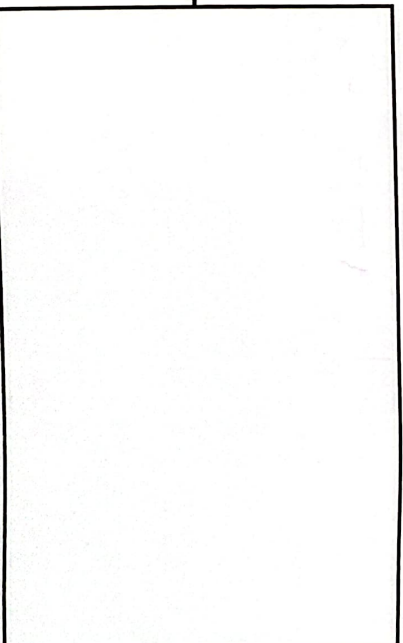

TMHE-Toyota Material Handling Europe — version 2, 2019-02-21

TOYOTA

MATERIAL HANDLING