

**Heat exchanger
oil / water
system: single tube**

AB-E 32-09
2003-04-09

Replaces: Issue 1999-05-04

1 Area of application

The coolers to this standard are suitable for cooling the following fluids:

Mineral oil
HLP to DIN 51524

Oil-water emulsion
HFA-E to VDMA 24317

Water emulsion
HFC to VDMA 24317

Phosphate ester
HFD-R to VDMA 24317

Fresh, river, sea and brackish water may be used as cooling medium (see table 3).

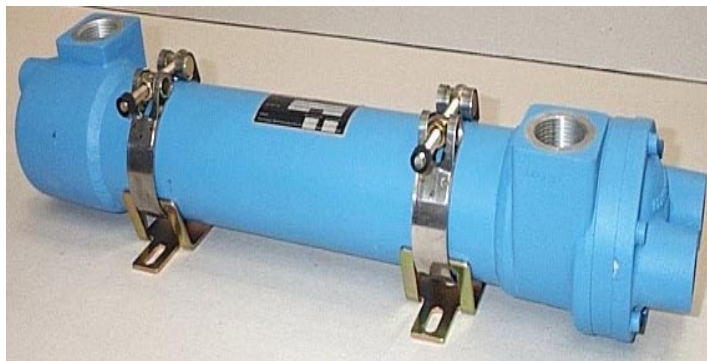

2 Model

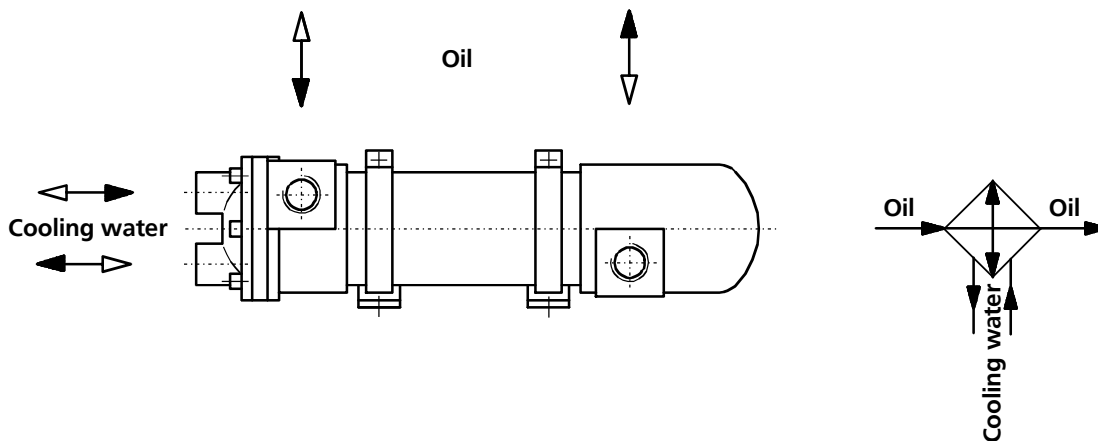

TYPE: AB32-09/110G-041-01

3 Type code

Example: **Waermetauscher** **AB32-09** / **056** **G** - **019** - **01** / **F**

AB standard

Nominal size

56	= 056
80	= 080
110	= 110
132	= 132

Connection type

Thread = G

Tube stack length

190	= 019
210	= 021
250	= 025
280	= 028
330	= 033
370	= 037
410	= 041
450	= 045
510	= 051
570	= 057
710	= 071
910	= 091

Material code (see table 1)

1	= 01
2	= 02

Clamp

Without clamp = without designation
 With feet = F

4 Ordering example

Heat exchanger nominal size 56 with threaded connection, tube stack length 370 and clamp with feet:
WAERMETAUSCHER AB32-09/056G-037-01/F Material no. **R900841985**

5 Selection table

Table 1

Designation: Waermetauscher	Material no.
AB32-09/056G-019-01/F	R900841987
AB32-09/056G-028-01/F	R900841986
AB32-09/056G-037-01/F	R900841985
AB32-09/080G-021-01/F	R900841984
AB32-09/080G-033-01/F	R900841988
AB32-09/080G-045-01/F	R900841991
AB32-09/110G-025-01/F	R900841993
AB32-09/110G-041-01/F	R900841995
AB32-09/110G-057-01/F	R900841996
AB32-09/132G-051-01/F	R900841998
AB32-09/132G-071-01/F	R900841997
AB32-09/132G-091-01/F	R900841999

Note:

Further options see material master.

6 Dimensions

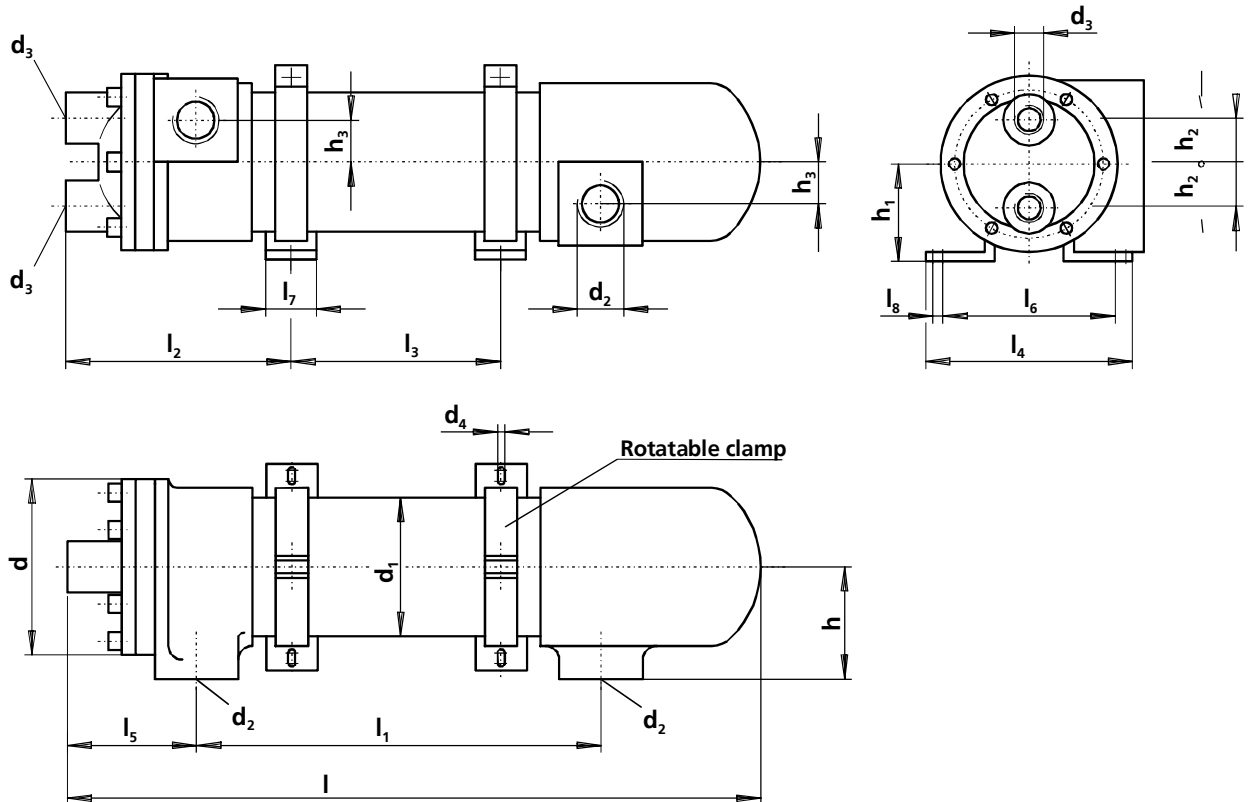

Table 2

DN	Tube stack length	Dimenisons																	
		d	d ₁	d ₂	d ₃	d ₄	h	h ₁	h ₂	h ₃	l	l ₁	l ₂ min.	l ₃ max.	l ₄	l ₅	l ₆	l ₇	l ₈
56 1)	190	82	56,6	3/4	1/4	8,5	43	42	16	14,0	280	149	145	-	110	71	64	50	15
56	280										239	135	110						
	370										460	329	135	200					
80 1)	210	108	80,9	1	1/2	8,5	62	51	27	23,5	300	156	160	-	110	81	64	50	15
80	330										276	150	140						
	450										540	396	150	260					
110 1)	250	142	110,4	1 1/4	1/2	9,0	75	64	35	38,0	390	203	195	-	156	95,5	100	60	18
110	410										550	363	175	200					
	570										710	523	175	360					
132	510	167	132,8	1 1/2	3/4	9,0	92	76	43	41,5	685	448	205	275	156	117	100	60	18
	710										885	648	205	475					
	910										1084	848	205	675					

DN	Tube stack length	Empty weight kg	Capacity	
			in the tubes l	around the tubes l
56 1)	190	1,7	0,15	0,3
56	280	2,4	0,18	0,4
	370	3,1	0,22	0,5
80 1)	210	3,5	0,30	0,6
80	330	4,9	0,40	0,9
	450	6,3	0,50	1,2
110 1)	250	7,0	0,80	1,5
110	410	10,1	1,00	2,3
	570	13,2	1,30	3,1
132	510	28,0	1,80	3,6
	710	24,0	2,30	5,0
	910	31,6	2,80	6,4

1) Fixing of the cooler is with a clamp

7 Material code

Table 3

Water type	Water quality	Source of supply	Material code
Fresh water	Drinking water	Municipal waterworks, springs	01
	Industrial water	Cooling tower circuits, factory wells	
	Stream and river water		
Sea water		High sea	02
Brackish water	Mixture of sea and river water	Coastal areas, mouths of rivers, harbours	

7.1 Remark

The material codes shown in table 3 are recommendations. Other combinations may be necessary according to the application. When using the cooler with well, stream, river or brackish water, a water analysis must be requested.

Table 4

Material code	01	02
Pipe	SF-Cu	CuNiFe
Tube base		Plastic
Casing		AlSi 12
Water chamber		GG 20

7.2 Regulation

On/off control of the cooling water by means of solenoid valve and thermostat is preferred to proportional control. Proportional control of dirty water causes floating particles to be desposited due to the low water velocity in the partial load range leading to corrosion. If river, sea or brackish water are used for cooling, a dirt trap with a mesh size of approx. 0,5 mm should be fitted in the supply line.

8 Calculations

Table 5

The minimum requirements to enable calculations are:		From these it follows that:
Oil flow	V_{OIL} (l/min)	$ETD = t_{OIL} - t_{KE}$ (K)
Power loss	P_V (kW)	Inlet temperature difference
Inlet temperature (oil)	T_{OIL} (°C)	$P_{01} = \frac{P_V}{ETD}$ (kW/K)
Inlet temperature (cooling water)	t_{KE} (°C)	Specific cooling capacity at $ETD = 1K$

$$\text{Cooling} \quad \Delta t_{OIL} = \frac{\text{HLP/HFD} \quad 36 \times P_V}{V_{OIL}} = \Delta t \frac{\text{HFC} \quad 17,2 \times P_V}{V} = \Delta t \frac{\text{HFA} \quad 14,7 \times P_V}{V} = (K)$$

$$\text{Heating H}_2\text{O} \quad \Delta t_k = \frac{14 \times P_V}{V_K} \quad (K) \quad \text{Cooling water requirements to table 8}$$

Example:

Given:

$P_V = 14 \text{ kW}$; $V_{OIL} = 50 \text{ l/min}$; $t_{OIL} = 60^\circ\text{C}$; $t_{KE} = 20^\circ\text{C}$

$$ETD = 60 - 20 = 40 \text{ K}; P_{01} = \frac{14}{40} = 0,35 \text{ kW/K}$$

Selected:

Type AB 32-09/08G-045-01 (see diagram 1)

$$\Delta t_{OIL} = \frac{36 \times 14}{35} = 14,4 \text{ K}; \Delta t_k = \frac{14 \times 14}{17} = 11,5 \text{ K}$$

9 Technical data

9.1 Diagram 1

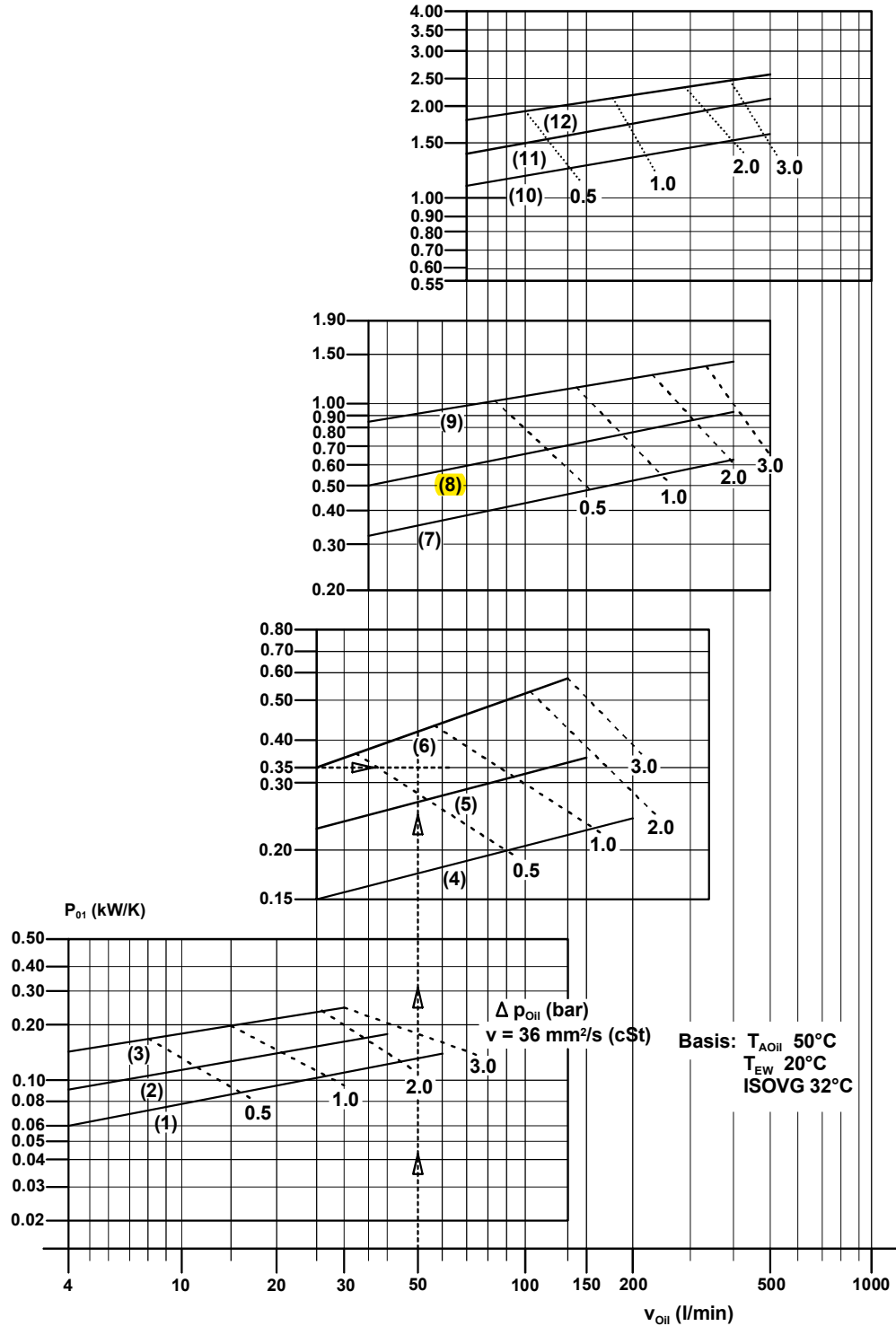

Table 6

Heat exchanger	Code in diagram 1
AB 32-09/056G-019-01	(1)
AB 32-09/056G-028-01	(2)
AB 32-09/056G-037-01	(3)
AB 32-09/080G-021-01	(4)
AB 32-09/080G-033-01	(5)
AB 32-09/080G-045-01	(6)

Heat exchanger	Code in diagram 1
AB 32-09/110G-025-01	(7)
AB 32-09/110G-041-01	(8)
AB 32-09/110G-057-01	(9)
AB 32-09/132G-051-01	(10)
AB 32-09/132G-071-01	(11)
AB 32-09/132G-091-01	(12)

10 Installation

The cooler may be mounted horizontally or vertically as required.

Pipe assembly (general rules)

The cooling water may only flow in and out via the covers, and the warm fluid only via the casing flanges. When connecting the water connections, no force should be used. The use of tapered fittings are not recommended.

Direction of flow

Due to the 4 way cooling water flow path, the direction of the oil and water flow can be selected as required. It is however recommended that the flow direction is as shown in the following diagram.

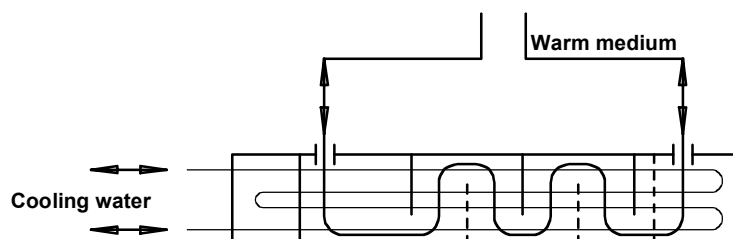

11 Spare parts

Table 11

DN	O-ring FKM		Qty. per cooler
	Dimensions	Material no.	
56	51,0 x 2	---	1
	51,5 x 3	---	
80	81,0 x 2	---	
	75,0 x 4	---	
110	110,0 x 2	---	
	105,0 x 4	---	
132	130,0 x 2	---	
	125,0 x 5	R900004487	

12 Assembly guidelines

For mounting the cooler onto the reservoir wall see AB 03-18 sheet 1.

13 For other standards see

[AB-E 32-..](#) Coolers and heaters