



Valve Solutions



Heavy Duty Pinch Valves
General Line Pinch Valves
Slurry Knife Gate Valves
Smart Features
Spares & Services

Valve solutions

For demanding shut-off and control applications

We deliver flow control solutions for the most demanding process conditions. Our story has started over 40 years ago making us the industry benchmark and experts on valve technology. During the years we have delivered over 150 000 products worldwide. Our robust full bore design enables effortless process flow. We provide services ranging from sizing, materials selection, installation, spare parts and maintenance to optimize the up and downstream flow.

Product portfolio

- 1977 • Pinch valves
- 2000 • Plastic body valves
- 2002 • Pumps introduced
- 2009 • Slurry knife gate valves



- 2016 • Digital Services
- 2017 • Filter service
- 2018 • Mobile geotextile dewatering unit, ceramic disc filters, filter presses, Smart Filtration Digital Service
- 2019 • Industrial automation, plasma technology for water purification, smart filter presses
- 2020 • Big knife gate valves DN900-1500

Focus Industries

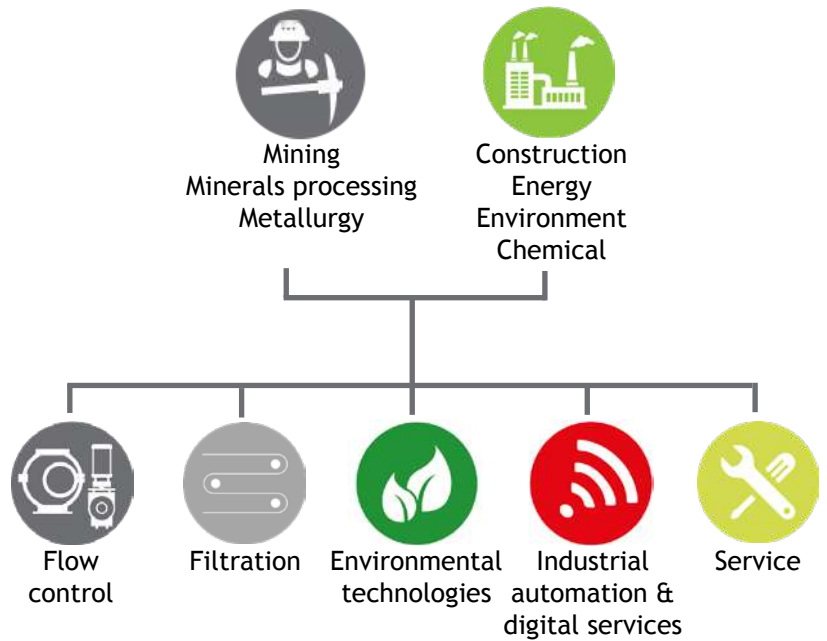

WE PROVIDE THE OPTIMAL SOLUTION:

Ball valve

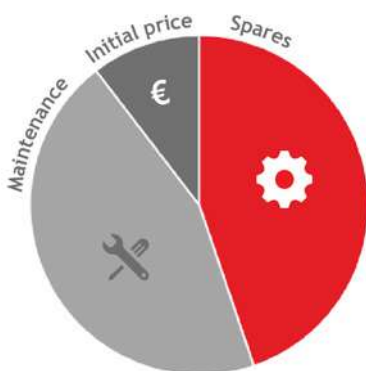

Flowrox valve solution



The shown comparison of cost over a period of 5 years on a DN100 pinch valve feeding abrasive slurry. The valve operates 4-6 times/hour. The conventional valve is a stainless ball valve with PTFE seats.

YOUR BENEFITS

- Low Total Cost of Ownership
- Low operating costs
- Improved process performance
- Long service intervals
- Minimized downtime
- Heavy duty design

Flowrox Valve Product Portfolio

> Pinch Valves



Heavy duty pinch valves

- Pressure rating up to 100 bar
- Size DN25 - 800
- High cycling applications
- For isolation & control purposes



PVG pinch valves

- Pressure rating 10 bar
- Size DN50 - 250
- Low cycling applications
- For isolation duty

> Slurry Knife Gate Valves



SKW

- Without flange
- Pressure rating 10 bar
- Size DN50 - 600
- Isolation duties only



SKF

- With flange
- Pressure rating 10 bar
- Size DN80 - 1500
- Isolation duties only



SKH

- With flange
- Pressure rating 20 bar
- Size DN80 - 600
- Isolation duties only

> Smart Solutions™



Enhance your performance with Smart Solutions™

- Smart valve series provide online information about the process, valve operations and condition of the valve.
- Enables advanced reporting and data analytics, making your process more reliable and transparent
- Fast analysis of faults and planning of maintenance

> Services



Comprehensive Valve Installation, Maintenance and Spare Services

- Site survey services
- Spare parts and component services
- Installation and maintenance services, repair services
- Analysis services / commissioning / training

Expansion project: Saving time during start-up with 330 Flowrox valves

Customer:

Trafigura Mining Group, MATSA mine, Spain

Products:

330 PVE enclosed body & PVG shut-off valves

Application: Ore & water treatment & process water supply in copper, zinc and lead mining

Benefits: Increased safety, easy installation & maintenance, process reliability, light-weight products.



Long-term benefits in ownership

The Tranfigura Mining Group ordered 330 Flowrox PVE enclosed body pinch valves and PVG shut-off pinch valves for various demanding flow control and shut-off duties, from ore treatment to water treatment plant and process water supply.

“When the project was engineered, we constantly had in mind that the choice of appropriate instrumentation for each application is fundamental to the process performance. We decided that all control valves and also some of the shut-off valves would be pinch valves, which finally ended up saving us a lot of time in the start-up of the plant,” says Ms. **Luisa Montes**, a Project Team Member from MATSA mine.

All installed Flowrox Pinch Valves delivered were an enclosed body type and include an SBRT valve sleeve to meet the requirements of various mediums in different process areas and to achieve the longest sleeve life time.

As the valves are self-cleaning, even if any solids are accumulated in the sleeve wall, it breaks away when the valve is operated. This is due to the flexibility of the sleeve, making the valve lifetime longer than many other competing products on the market.

The Flowrox Pinch Valves were chosen to gain long-term benefits based on low total cost of ownership. The PVE control valves at the plant are actuated by pneumatic double acting actuators with positioners. Also, all of the on/off PVG valves include limit switches for position indication.

“In the future, we are definitely expecting cost savings,” Ms. Montes states.



OUR CUSTOMER: TRAFIGURA MINING GROUP

Trafigura Mining is a market leader in copper, lead and zinc concentrates trading. The flagship mine, Aguas Teñidas (MATSA), is located in Andalucía, Spain. In the year 2015, the production of concentrates nearly doubled to 4,4 tons per year.



Flowrox Valve References

- > **Customer:** HUSAB Uranium Mine, Namibia
- Products:** Pinch valves
- Application:** Tailings Transfer
- Benefits:**
- Increased process reliability
 - Cost efficiency with remote valve control
 - Low total cost of ownership



- > **Customer:** Wastewater treatment plant, Warsaw, Poland
- Products:** DN500 control pinch valves
- Application:** Flow control of biological sludge
- Benefits:**
- Gentle handling due to living bacteria in sludge
 - Wide and accurate flow control range
 - Extended maintenance interval



- > **Customer:** LKAB, Sweden
- Products:** PV and PVE pinch valves
- Application:** Thickener underflow
- Benefits:**
- Reliability with abrasive slurry
 - Wide and accurate flow control range
 - Extended maintenance interval



Heavy Duty Pinch Valves

Flowrox heavy duty pinch valves are “The pinch valves”. They are made to last and are ideal where shut-off and control applications involve abrasive or corrosive slurries, powders or coarse substances.

Made to Last

The operating principle of Flowrox pinch valves is simple. In the open position, the valve is full bore with no flow restrictions. During closing, two pinch bars squeeze the valve sleeve shut on the centerline. The sleeve is naturally wear resistant and when particles hit the sleeve’s rubber surface, the energy is absorbed and released when the rubber bounces back.

Heavy duty pinch valves provide bubble tight shut-off even if solids have built up on the sleeve wall. When compressed, any crystallized particles flake off the sleeve surface. The full bore structure ensures free flow of the medium. The construction and materials of the three main components (sleeve, body and actuator) can be tailored to suit your process conditions.

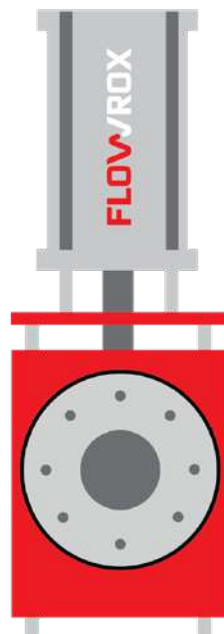

Benefits: This Is How We Flow!

- Long service intervals
- Only one wearing part
- Excellent for dry powders
- Low maintenance cost

Image: During closing, two pinch bars squeeze the valve sleeve shut on the centerline. See the Pinch Valve in action by scanning the QR code.

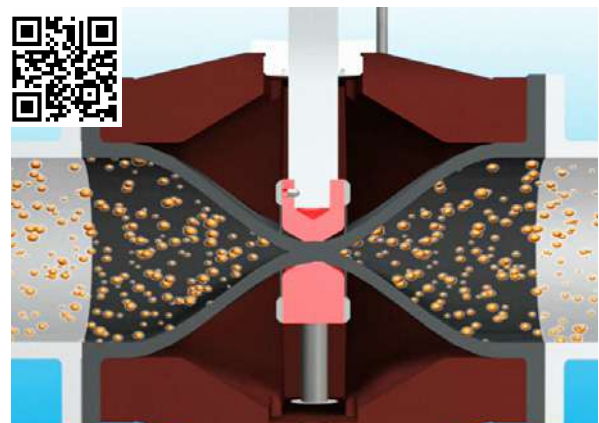

Valve Model Selection Guide

| Type | Size (DN) | Actuator | Pressure class | Flange drilling | Body material | Shape of flange | Opening tags | Auxiliaries | Sleeve material |
|--|----------------------------|--|--|---|--|--|-------------------------|--|---|
| PV = open PVE = enclosed PVE/S = enclosed / sealed PVS = sealed | 25 100 DN 100 | M = manual MG = manual with gear A = pneumatic AB = with manual override AK = with el.pneum. positioner AKU = with el.pneum. positioner & pneum. spring AKV = with el.pneum. positioner & mech. spring AKF = with integrated Festo positioner AN = with pneum. positioner AU = with pneum. spring AV = with mech. spring E = electric EO = with electrical positioner H = hydraulic HP = hydraulic with positioner | 1 = 1 bar 6 = 6 bar 10 = 10 bar 16 = 16 bar 25 = 25 bar 40 = 40 bar 64 = 64 bar 100 = 100 bar | 1 = - 2 = DIN PN10 3 = DIN PN16 4 = DIN PN25 5 = DIN PN40 6 = ANSI150 7 = ANSI300 8 = BS TABLE D 9A = AS TABLE D 9B = AS TABLE E 9C = JIS 10 9D = JIS 16 9 = OTHER | 0 = GRS/Fe 2 = AISI 316 3 = aluminium 4 = other 5 = polyurethane/polyamide | type 1 type 3 type 4 Determined by Flowrox | L = opening tags | R = readiness for ind. limit switches R1 = AC/DC R2 = DC, PNP R3 = DC, NPN S = magnetic limit switches T = mechan. limit switches Q = quick exhaust valve Z1 = solenoid valve, 24VDC Z2 = solenoid valve, 230V, 50/60 Hz Z3 = solenoid valve, 110V, 50/60 Hz F = Filter regulator + Gauge J1 = Junction box small J2 = Junction box large X = must be specified | SBRT = Styrene butadiene EPDM = Ethylene propylene NR = Natural rubber NBR = Nitrile CSM = Hypalon EPDMB = Green liquor sleeve CR = Chloroprene IIR = Butyl NRF = Foodstuff natural rubber NBRF = Foodstuff nitrile HNBR = Hydrogenated nitrile FPM = Fluorine rubber /M = SensoMate sleeve /PU = PU-coating inside the sleeve /VAC = Sleeve for suction |

Example: PVE 150A10-203LR1Z2, SBRT

Control Valves

The Flowrox control valves are designed for demanding control applications in which conventional valves encounter problems with wear due to increased turbulence.

When the controlled flow is abrasive, it is a big advantage to have only one, wear resistant, valve part in contact with the medium. The need for maintenance and spare parts is reduced.

Controllability can be further improved with conical sleeves or smart positioners.

Flowrox control valve sizing is based on international IEC60534 standard (harmonized with ANSI/ISA S75).

Flowrox Control Valve Sizing Program is available to ease your work.

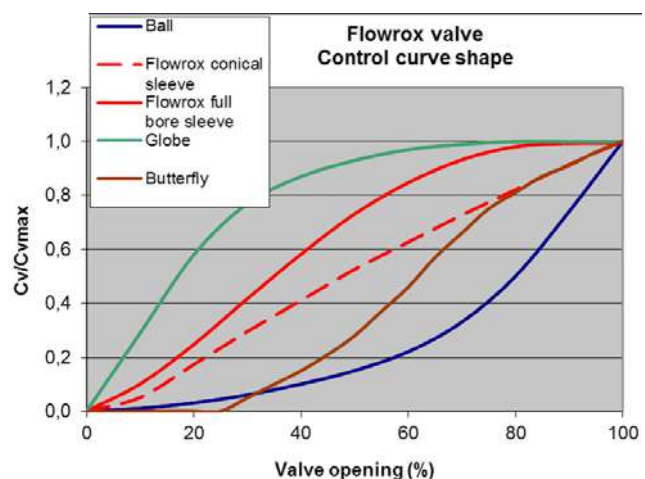

General Line Pinch Valves

PVG and PVEG valves

Flowrox pinch valves are robust and cost-effective valves with simple, single-sided closing mechanism. PVG valves have a strong valve body and opening tags in the sleeve as standard. PVEG valves have a corrosion resistant and light-weight plastic body.

They are ideal for low cycle applications involving abrasion, corrosion and aggressive slurries. Through the reliability and structure, they offer substantial savings based on improved performance, long service lifetime and low total cost of ownership.

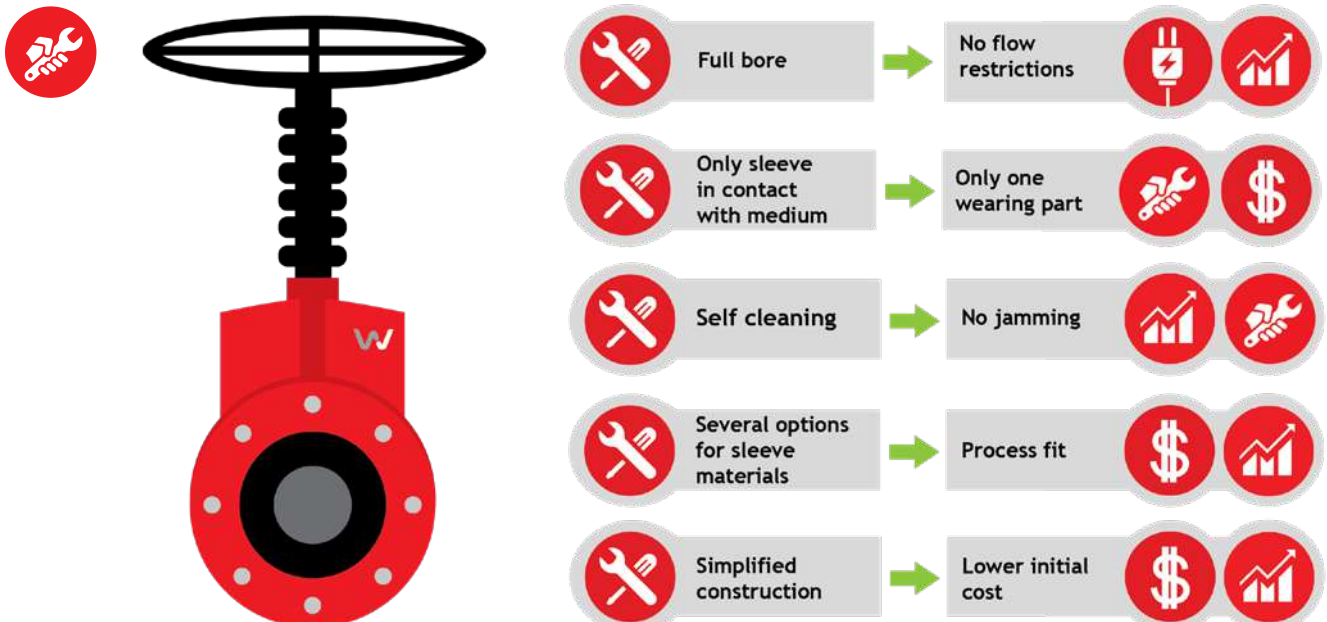

Benefits: This Is How We Flow!

- Long service intervals
- Only one wearing part
- Excellent for dry powders
- Simple sleeve replacement

Image: The closing element squeezes the sleeve shut against the lower body half, providing a 100 % tight shut-off. See the PVG in action by scanning the QR code.



PVG Valve Model Selection Guide

| Type | Size (DN) | Actuator | Pressure class | Flange drilling | Body material | Sleeve material | Auxiliaries |
|---------------------------|-----------|---|---------------------------------------|--|---------------|--|--|
| PVG = Flowrox Pinch valve | 50 - 250 | M = manual A = pneumatic E = electric | 4 = 4 bar 6 = 6 bar 10 = 10 bar | 2 = DIN PN 10 6 = ANSI 150 9 = other | 0 = cast iron | SBRT = Styrene butadiene rubber EPDM = Ethylene propylene diene monomer | Z1 = solenoid valve, 24V DC Z2 = solenoid valve, 230V 50/60 Hz Z3 = solenoid valve, 110V DC S = Magnetic limit switches |

Example: PVG 50M10, SBRT

PVEG Valve Model Selection Guide

| Type | Size (DN) | Actuator | Pressure class | Flange drilling | Body material | Sleeve material | Auxiliaries |
|------------------------------|-----------|-----------------------------|--------------------------|--|---------------|---|---|
| PVEG = Flowrox Pinch valve | 50 - 150 | M = manual A = pneumatic | 6 = 6 bar 10 = 10 bar | 2 = DIN PN 10 6 = ANSI 150 9 = other | 5 = Polyamide | SBRT = Styrene butadiene rubber | Z1 = Solenoid valve, 24V DC Z2 = Solenoid valve, 230V 50/60 Hz |
| PVEG/C = Flowrox Pinch valve | 50 - 150 | M = manual A = pneumatic | 6 = 6 bar 10 = 10 bar | 2 = DIN PN 10 6 = ANSI 150 | 5 = Polyamide | EPDM = Ethylene propylene diene monomer | Z3 = Solenoid valve, 110V DC S = Magnetic limit switches |

Example: PVEG 150M10-25

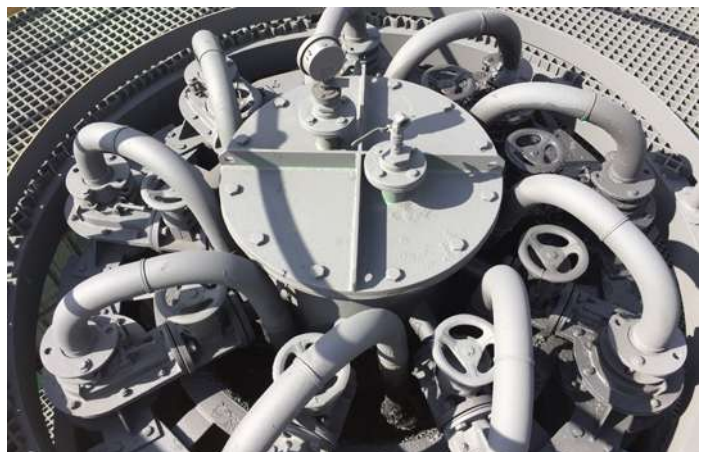

Image: PVEG50M manual polyamide body pinch valves in a hydrocyclone at Kara Mine, TMM, Tasmania, Australia.

Knife Gate Valves

Heavy Duty Slurry Knife Gate Valves isolate flow, even in the most demanding process conditions. The complete valve is built around an ease-of-maintenance concept.

Slurry Knife Gate Valves

The designs of Flowrox Slurry Knife Gate Valves are based on the years of experience Flowrox has gained, providing reliable solutions for abrasive and corrosive process applications.

They feature a load distribution ring that prevents over compression and ensures tight sealing between the sleeve and the valve gate. To add to the ease of maintenance, the load distribution ring has been integrated into the sleeves of the valve.

The universal tower design of the valve accommodates most actuator types, allowing for actuator interchangeability. The tower also ensures that the top plate, body and actuator are always aligned and that the gate is in the right position. The valve body itself is a one-piece casting, eliminating the need for sealing between the body halves.

Flowrox SKF knife gate valves DN 900-1500 use a new approach. Instead of tower design, two actuator cylinders are positioned to the sides.

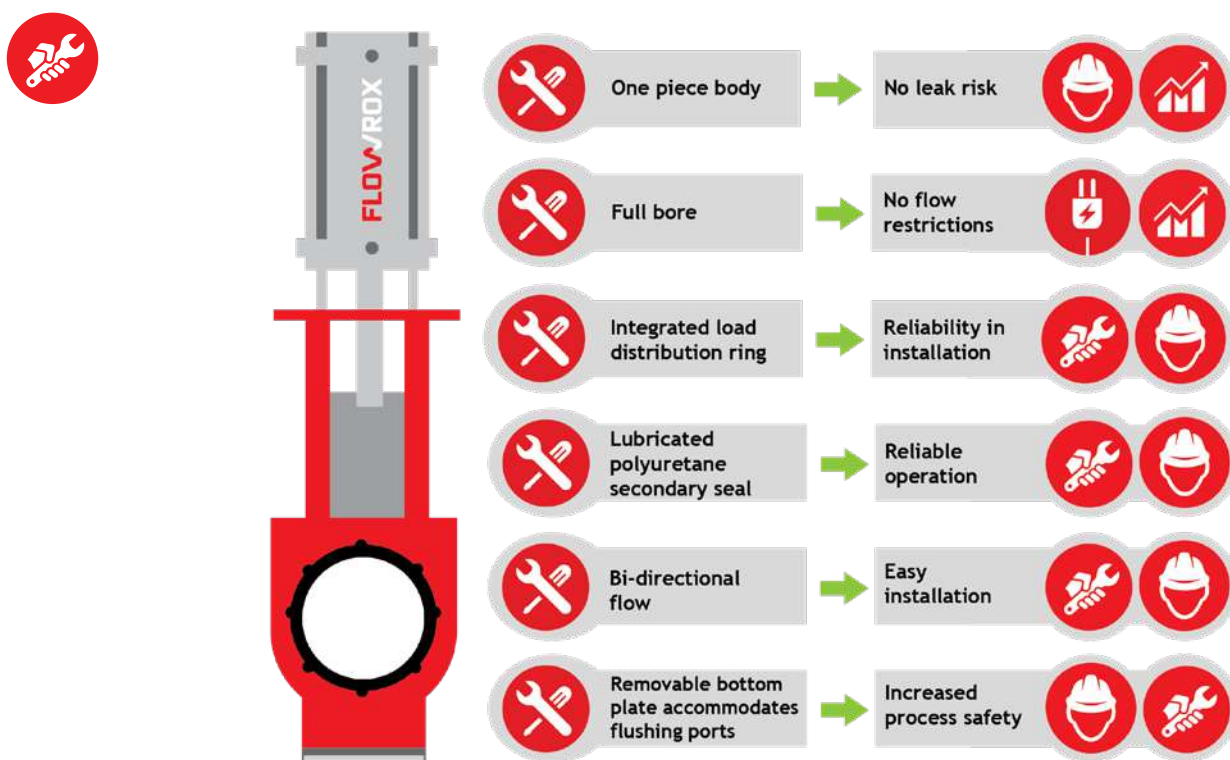

Benefits: This Is How We Flow!

- Small face-to-face dimension
- Easy installation
- Available in large size scale
- Low maintenance cost

Image: Elastomer sleeves on both sides of the gate provide a tight shut off. See the Flowrox knife gate valve in action by scanning the QR code.



SKW / SKF Valve Model Selection Guide

| Type | Size (DN) | Actuator | Pressure class (PN) | Flange drilling | Body material | Gate material | Ring sleeve material | Auxiliaries |
|---|-----------|--------------------------------------|---------------------------------------|-----------------|--------------------------------|---------------------|---------------------------|-------------------------------------|
| SKW = Slurry knife gate valve wafer | 50 - 600 | M = manual | 10 = 10 bar standard | 2 = DIN PN10 | 0 = Cast iron/ Ductile iron | S = stainless steel | NR = natural rubber | R = readiness for inductive limits |
| | | MG = manual with gearbox | | 3 = DIN PN16 | | | | |
| SKF= Slurry knife gate valve with flanges | 80 - 1500 | A = pneumatic | 10 = 10 bar 6 = 6 bar 4 = 4 bar | 4 = DIN PN25 | 4 = other | Others on request | EPDM = ethylene propylene | R2 = DC, PNP |
| | | AU = pneumatic with pneumatic spring | | 5 = DIN PN40 | | | | R3 = DC, NPN |
| | | H = hydraulic | | 6 = ANSI150 | | | | Z1 = solenoid valve, 24V DC |
| | | E = electric | | 7 = ANSI300 | | | | Z2 = solenoid valve, 230V, 50/60 Hz |
| | | | | 9 = other | | | | Z3 = solenoid valve, 110V, 50/60 Hz |
| | | | | | | | | G = guard |

Example:SKW 100M10-20S0-NR-G

SKH Valve Model Selection Guide

| Type | Size (DN) | Actuator | Pressure class (PN) | Flange drilling | Body material | Gate material | Ring sleeve material | Auxiliaries | | | | |
|---|-------------|--------------------------------------|----------------------|-----------------|--------------------------------|---------------------|----------------------|------------------------------------|-------------------------------------|-------------------|---------------------------|--------------|
| SKH = High pressure slurry knife gate valve | 80 - 600 | MG = manual with gearbox | 20 = 20 bar standard | 2 = DIN PN10 | 0 = Cast iron/ Ductile iron | S = Stainless steel | NR = natural rubber | R = readiness for inductive limits | | | | |
| | | A = pneumatic | | 3 = DIN PN16 | | | | | 2 = AISI 316 | Others on request | NBR = nitrile | R1 = AC/DC |
| | | AU = pneumatic with pneumatic spring | | 4 = DIN PN25 | | | | | 4 = other | | EPDM = ethylene propylene | R2 = DC, PNP |
| | | H = hydraulic | | 5 = DIN PN40 | | | | | Z1 = solenoid valve, 24V DC | | | |
| | | E = electric | | 6 = ANSI150 | | | | | Z2 = solenoid valve, 230V, 50/60 Hz | | | |
| | 7 = ANSI300 | Z3 = solenoid valve, 110V, 50/60 Hz | | | | | | | | | | |
| | | | 9 = other | | | | G = guard | | | | | |

Example:SKH 200E20-30S0-NR

Slurry Knife Gate Design, DN50-800

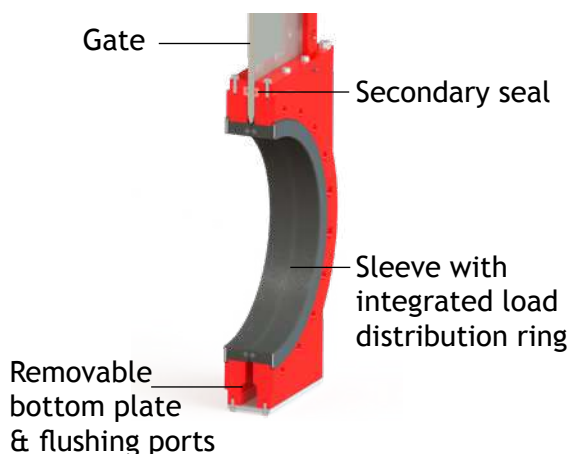

Slurry Knife Gate Design, DN900-1500

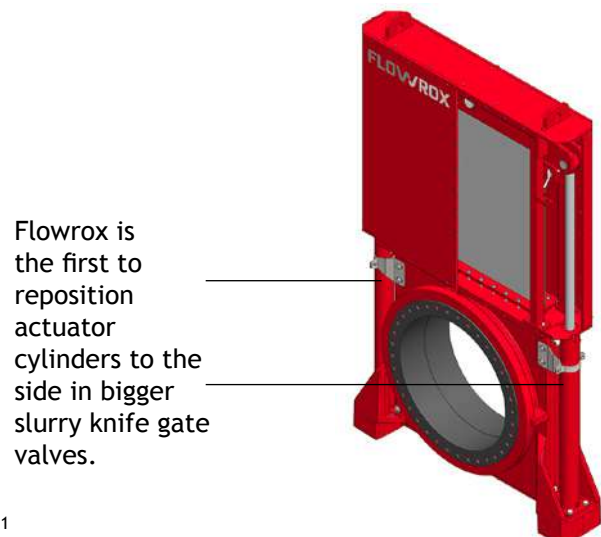

Smart Features

Enhance your performance with Digital Services. Flowrox Smart features can be included into any old or new delivery. The Smart valves are next generation solutions delivering data and information in order to provide reliable and cost-efficient production. Real time information from site results in optimized production with maximized output and minimized unplanned shutdowns.

Digital Services

Flowrox Smart valves provide you with online information about their condition, process and operations.

Flowrox Smart PVE is based on the reliable PVE valve and is equipped with a new smart positioner for detailed information about valve operations. The SPVE includes a leak sensor and various embedded instruments for additional information.

Optional SensoMate Smart sleeve detects the wearing before actual sleeve failure.

The Flowrox Smart Valve combined with the Flowrox Malibu™ IIoT user interface enables advanced reporting and data analytics, making your process more reliable and transparent. Malibu is accessible on any device with an Internet browser.



Technical Features

- Pre-fail indications
- Real time data in Flowrox Malibu
- Pressure measurement at the valve inlet/outlet
- Medium temperature measurement
- Leak sensor
- Connectivity with 3G/4G, WIFI or LAN

From Features to Benefits

- **Online valve performance monitoring**
 - ➔ Detect issues before they become a problem
- **Automatic pre-fail indications**
 - ➔ Savings in maintenance & unexpected shutdown costs
- **Analytics tools**
 - ➔ Help you make the correct decisions fast
- **Advanced reporting tools**
 - ➔ Access to detailed asset performance information
- **Easy accessibility via Internet**
 - ➔ Access where ever you are



The Flowrox smart instrumentation can be retrofitted to automatic pinch valves.



Flowrox Digital Services:

The smart valve SPVE series provides online information about the process performance and condition of the valve.

The Flowrox Smart Valve combined with Flowrox Malibu™ enables advanced reporting and data analytics, making your process more reliable and transparent.

Spares & Services

Sleeves: The core of our valves

Our technologically advanced Flowrox sleeves guarantee high resistance to wear and corrosion, trouble-free operation and extended lifetime.

Robust Heart of the Pinch Valve

The handmade sleeve has a reinforced construction, making it the pressure-containing part of the valve.

Standard Flowrox PV, PVE and PVG sleeves are equipped with opening tags to ensure full valve opening in all process conditions.

Sleeves for Knife Gate Valves

The sleeve is a moulded part with a reinforcement steel ring integrated near the sealing area. The flange of the sleeve is reinforced with a load distribution ring to ensure even compression.



Special Sleeve Features

- Conical sleeve for control valves
- Suction sleeve for negative pressure applications
- SensoMate sleeve detecting and signalling critical wear
- Polyurethane lined sleeve with improved protection against wear in abrasive control applications
- Foodgrade rubber for FDA requirements

Opening tags

Reinforcing cords

Wear-resistant inner lining

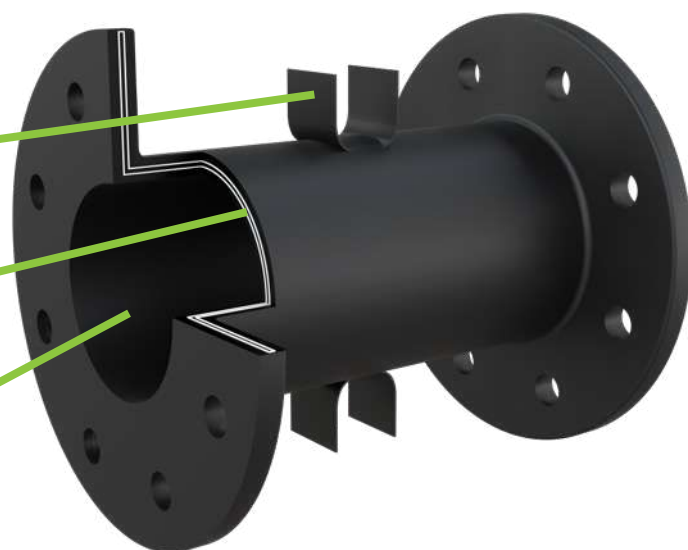

To cover a wide range of applications, several rubber compounds are available.



Flowrox valves are available in various sizes and models for various applications. Flowrox Services supports you throughout the entire life cycle.



Services

We offer prompt support, spare parts and services in order to maximize your performance.

We manufacture and deliver original spare parts and components for all Flowrox products (valves, hose pumps, PC pumps).

- On-time trouble-free delivery of spares and services
- Cost savings through optimized service cycles and reduced downtime of equipment
- Longer life cycles for equipment





This is how we flow!

Check out the **Flowrox Pinch Valves** in action by scanning this QR code.



Open your gates!

Check out the **Flowrox Knife Gate Valves** in action by scanning this QR code.



Get Smarter!

Check out the **Flowrox Smart Solutions™** by scanning this QR code.



Flowrox: Proven Performance

Flowrox is a family-owned global company headquartered in Finland. It specializes in flow control, pumping, filtration solutions and environmental technologies. Flowrox products and services are enhanced with IIoT solutions and intelligent systems. Flowrox serves a number of process industry applications, especially in mining, minerals processing, chemical, energy and environmental industries.

Flowrox has subsidiaries in Australia, Chile, China, Peru, South Africa, Russia, Sweden and the United States as well as more than 230 sales representatives in over 80 countries.



Contact your local Flowrox representative



Flowrox Oy
P.O. Box 338, FI-53101 Lappeenranta
Finland
Tel. +358 201 113 311

www.flowrox.com
info@flowrox.com

