



WEIR

Minerals

Linatex® Rubber Products
Hose Range

WEIR **Linatex**
Rubber Products
B18 HI PD VLA
100



**We don't make 'standard' hoses.
We custom-build our Linatex® hose systems to
deliver outstanding wear performance,
every time you need it.**

Linatex® specialty hoses are expertly built to provide superior wear performance in the toughest abrasion environments.



At Weir Minerals our collective global experience and expertise in the design and manufacture of custom-made material handling hose is second to none.

Built to deliver outstanding wear performance in the most demanding applications, our hose products have rightly won a reputation for reliability and long wear life. They are industry compatible with a wide range of processing plants, and are fitted as standard equipment to many leading systems across the globe.

Our Linatex® specialty hose range incorporates slurry and chemical mining hose, dredge hose and a wide variety of preformed bends, reducers and T-pieces, all of which are available with a versatile array of end types. Our state-of-the-art computer controlled lathes ensure that the application of material in the hose construction is consistent. This makes for a high quality hose construction that is both robust and reliable.

When you choose to install our proprietary wear indicator technology for Linatex® hoses you are taking advantage of our cutting-edge technology, and are making a step towards improving both the safety and environmental impact of your site.

With sites across the globe, and a distribution network unparalleled in the industry, we can deliver application-engineered hose systems to you, wherever you are. Whenever you work with one of our local representatives, you are supported by the know-how of a global team.

Our extensive knowledge of wear performance compounds, together with our leading edge technology, ensures that all our hose systems are built to last.



Raw Materials

We believe that quality raw materials are the key to manufacturing premium specialty hose. When we design and custom build your hose, you can rely on receiving a superior wear resistant hose created with the highest quality rubber compounds, reinforcement cords and end connections.

Wear liner composition is critical to the performance of your hose. With over 90 years of rubber manufacturing experience, we have the expertise to select the best composition for your specified application. Our extensive knowledge of wear performance compounds ensures that our products are built to last.

Our hoses are created using traditional reinforcement materials such as nylon or polyester. High tensile aramid fibre reinforcement is also used in our highly customised large bore hose designs.

Reinforcement cord materials are selected to complement our designs during the engineering process.

Innovation

Our engineers lead the way in technological advancements, constantly improving our hose products to make your job easier.

For example, our unique wear indicator technology for hose is a wireless early warning system that alerts operators to hose wear in highly abrasive materials handling applications. The technology ensures that environmental spills, costly emergency downtime, and health and safety incidents are significantly reduced or eliminated.



Design Features

The unique Linatex® premium rubber compounds provide your product with superior wear resistance and extended wear life. This is designed to achieve the lowest total cost of ownership.

Our entire hose range is supported by our extensive technical and design facilities. This allows for full customisation to meet your specific requirements that, in turn, reduces commissioning and installation inefficiencies.

Our specialty hose range features:

- Various compounds to suit specific applications
- A variety of standard and custom-made bore sizes and lengths
- Specialised end fittings to suit individual applications
- Individual labelling for traceability of hose details
- Our Hose Audit Service that provides onsite evaluation/review of all hose issues including suitability and safety
- Hydrostatic testing available
- Support by our experienced field representatives who provide on-site assessment and advice
- Cutting-edge wear indicator technology ensuring critical hose monitoring confidence



At Weir Minerals we pride ourselves on delivering total hose solutions. We also supply an extensive array of complementary hose products to suit your unique application.

The Right Hose for the Job

We understand that each of our customers has unique needs and specific requirements. We will work closely with you to ensure that you achieve the best hose solution for your site.

We will custom-design to any size, with hose diameters in excess of 1m/40in and lengths up to 15m/50ft available.

Our hoses are designed to accommodate standard or custom flange types. Other options include built in nipples, victaulic end connections, and plain or cuffed ends.

We custom manufacture to nominated length and engineer to required pressure. We also offer a variety of compounds and wear liner gauges to best suit the duty.

Our Specialty Hose Range:

Slurry hose

- Hard wall slurry hose (808)
- Hard wall slurry hose bends (808-PHB)
- Soft wall slurry hose (806)
- Adaptable slurry hose (888)

Cut end hose

- Smooth cut end hose (801)
- Corrugated cut end hose (800)

Chemical hose

- Acid/chemical hose (700)
- Hose bends
- Reducers

Dredging hose

- Gimble and trunnion suction hose
- Self floater hose
- Discharge hose

Bellows and Reducers

Hose bellows and reducers, or custom engineered designs are available.

Please Note: Not all products referred to in this brochure are available in all regions. Please contact your local representative for more details and information.

Compounds and Liners

Our global presence combined with our vast experience across a variety of industries allows us to confidently provide a complete solution for your application:

- Linatex® Premium Rubber
- Linacure® 40
- Linacure® 60
- Linagard® FG
- Linagard® OSR
- Linard® 60
- Linard® HD60

Other compounds available include:

- EPDM
- Neoprene Chlorobutyl

Our hoses are created using traditional reinforcement materials such as nylon or polyester. Alternate materials, such as aramid fibres, may also be used.



Our custom designs allow us to engineer a range of end connections to suit your needs.

Hose End Types

Fixed Flange

Fixed flange ends are recommended for hoses that have medium working pressures and subject to low stresses during application.

The rubber and fabric reinforcement of the hose body is extended to form a full face flange that is backed by a full circle or split ring metal backing plate.



Swivel Flange

Swivel flange ends have the ability to rotate the backing flange, and are designed as an alternative to fixed flange ends. Swivel flanges allow ease of alignment of the bolt holes.



Double Flanges

The double flange arrangement is designed for use on hoses subject to high axial loads. The twin steel flanges are built-in and able to withstand considerable bend loads while maximising flexibility from the hose. The front flange is encapsulated in rubber and reinforcement cord, providing protection against corrosion.



Custom Couplings

Custom Couplings are fully rubberised, built-in couplings that are available in **swivel** or **fixed** flange configurations. Custom couplings are mainly used in dredging and high performance/pressure slurry applications.

The built-in coupling tail piece is adaptable to various fittings including victaulic, rotating, fixed flanges and proprietary couplings.



Split Cast Coupling

This two-piece external coupling is designed for use on our cut end hose. The coupling does not come into contact with the internal hose flow, making it highly suitable for abrasive slurries.



Please Note: Hose flange types are custom designed to suit your flange drill pattern requirements.

When you invest in our hose, you get more than just a hose, you receive a product that is made from the best raw materials, custom engineered to your exact requirements, and backed up by our ongoing, onsite technical support.



Experience the Difference

We are proud to be the market leader. We set the international benchmark for rubber used for abrasive materials handling across all mining applications.

We are not just leading the way in the mining industry, we are also suppliers of premium hose and end fittings for other industries. Our dredge flex hose is the equal of any dredge hose in the field. When our solution focused engineering capabilities are taken into consideration, we have become the preferred option when selecting dredge hose for your operation.

By imposing strict quality control measures and testing samples at every step of production, we ensure long lasting industrial wear solutions that are the most cost effective. With hose available in either our renowned Linatex® premium rubber or a variety of compounds, we deliver the right hose for every job.

Superior design capabilities and build quality, as well as our customer service, is what sets our hose apart. And our unique wear indicator technology demonstrates our commitment to harnessing technological innovations to make your job easier and your site safer.

Global production facilities allow us to meet short manufacturing lead times and our extensive distribution network ensures prompt delivery, no matter where you are.

In a diverse range of materials handling applications, our hose products have proven to consistently outperform and outlast competitor products. To find out more, read about our in-the-field success stories at www.weirminerals.com

For more information about our specialty hose range, please refer to our comprehensive range of Hose Product Specification Sheets (featured in this brochure or available separately), or contact your local representative.



Linatex® Hose Range Technical Specifications

	PAGE
Linatex® 808 Hard Wall Slurry Hose	10
Linatex® 808-PHB Hard Wall Slurry Hose Bend	11
Linatex® 806 Soft Wall Slurry Hose	12
Linatex® 888 Adaptable Slurry Hose	13
Linatex® 800 Corrugated Cut End Hose & Couplings	14
Linatex® 801 Smooth Cut End Hose & Couplings	15
Linatex® 700 Acid/Chemical Hose	16
Linatex® Slurry Hose Reducers	17
Linatex® 1000 Dredge Flex Hose	18

Linatex® Hard Wall Slurry Hose (808)

Technical Specifications

Design Features

- Superior wear performance in fine slurry abrasion
- Robust and versatile
- Available with Linatex®, Linacure® or Linard® abrasion resistant internal wear liners
- Designed and manufactured to customer requirements
- Inbuilt end connections
- High tensile reinforcement cord with a steel wire helix

Applications

Pumping and transfer of abrasive slurries under pressure or vacuum for:

- Mineral processing plants
- High pressure tailings lines
- Sand and gravel transfer
- Lime transfer
- Oil sands

Properties

- Nominal bores from 50mm (2") to 1000mm (40")*
- Lengths up to 15m (50ft)**
- Operating temperature -35°C to +75°C (-31°F to +167°F)
- Suitable for discharge and vacuum duties
- Minimum bend radius of 8-10 times the internal diameter



Proven superior abrasion resistance

The Linatex® 808 hard wall slurry hose range is custom built and designed to deliver outstanding wear performance in the most arduous of mining and industrial applications. Our world renowned wear resistant rubber compounds complement our hose range and offer our clients the lowest cost of ownership.

Our hoses are custom manufactured to an extensive range of bore sizes, lengths, pressures and end coupling arrangements. Some of the many connection options include fixed flanges, swivel flanges and spigot ends, custom designed and built to cater for high pressure and high tow strain applications.

The Linatex® 808 hard wall slurry hose construction is the product of choice in many of the world's leading mine sites. Our design and manufacturing versatility, and the superior wear performance of Linatex® premium rubber, has rightly won our mining hose a reputation for its outstanding reliability.

Typical Physical Properties

NOMINAL BORE		TYPICAL WEAR LINER THICKNESS		WORKING PRESSURE kPa	BEND RADIUS	
mm	in	mm	in		mm	ft
50	2	6	¼	Atmospheric Pressure to 5000 kPa	400	1.31
75	3	6	¼		600	1.97
100	4	6	¼		800	2.62
125	5	6	¼		1000	3.28
150	6	6	¼		1200	3.94
200	8	6	¼		1600	5.25
250	10	10	⅜		2000	6.56
300	12	10	⅜		2400	7.87
350	14	10	⅜		2800	9.19
400	16	12	½		3200	10.50
450	18	12	½		4050	13.29
500	20	12	½		5000	16.40
600	24	12	½		7200	23.62

Note: * Custom internal diameters are also available.

** Product specifications are subject to regional variations.

Linatex® Hard Wall Slurry Hose Bend (808-PHB)

Technical Specifications

Design Features

- Designed to achieve superior wear performance over traditional steel lined pipe bends
- Lining thickness can be increased without reduction in the internal diameter
- Available with an extensive array of diameters, bend angles and radii configurations and may be customised to your needs
- Available with Linatex®, Linacure® or Linard® abrasion resistant internal wear liners

Applications

Pumping and transfer of abrasive slurries under pressure:

- Mineral processing plants
- Sand and gravel plants
- Tailings lines
- Oil Sands

Properties

- Nominal bores from 50mm (2") up to 1150mm (45")*
- 1.5D, 3D and 5D bends fully interchangeable with pulled steel bends**
- Operating temperature -30°C to +75°C (-22°F to +167°F)
- Safety factor of 4:1



Installation made easy

The Linatex® 808-PHB hard wall slurry hose bend range is renowned for its robust design and performance in delivering outstanding wear resistance in critical high wear applications. Manufactured to the same high standard as our 808 hard wall slurry hoses, our formed hose bends are custom produced to your required internal diameter, bend angle, radii and centre line to face requirements.

The hot-vulcanised manufacturing process provides a made-to-order formed hose bend that is designed to fit the application without the need for excessive flexing. And the inbuilt swivel flanges make installation extremely easy. Our Linatex® 808-PHB hard wall slurry hose bends are the product of choice for many customers.

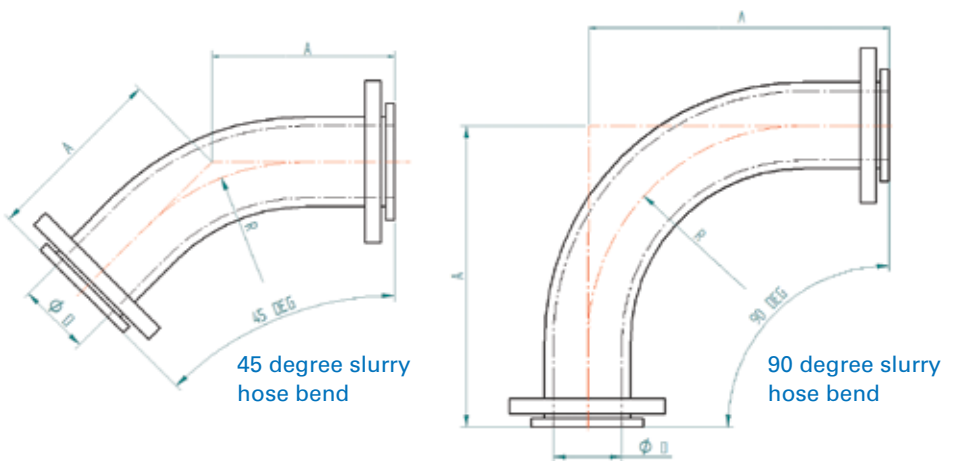

Typical Physical Properties - 3D Bends

NOMINAL BORE (D)		TYPICAL WEAR LINER THICKNESS		RADIUS (R)		90° (A)		45° (A)	
mm	in	mm	in	mm	in	mm	in	mm	in
150	6	6	¼	457	18	607	23.9	339	13.3
200	8	10	¾	610	24	760	29.9	403	15.9
250	10	10	¾	762	30	912	35.9	466	18.3
300	12	12	½	914	36	1114	43.9	579	22.8
350	14	12	½	1067	42	1267	49.9	642	25.3
400	16	12	½	1219	48	1419	55.9	705	27.8
450	18	12	½	1372	54	1572	61.9	768	30.2
500	20	12	½	1524	60	1724	67.9	831	32.7
600	24	15	⅝	1829	72	2029	79.9	958	37.7

Note: * Custom internal diameters are also available.

** Product specifications are subject to regional variations.

Linatex® Soft Wall Slurry Hose (806)

Technical Specifications

Design Features

- Durable construction with high tensile reinforcement cord
- Allows for compression and rebound
- Inbuilt end connections
- Available with Linatex®, Linacure® or Linard® abrasion resistant internal wear liners
- Designed and manufactured to customer requirements

Applications

Pumping and transfer of abrasive slurries under pressure for:

- Mineral sands stacker lines
- Sand and gravel transfer
- High pressure tailings lines
- Intake and discharge connectors

Properties

- Nominal bores from 50mm (2") to 1000mm (40")*
- Lengths up to 15m (50ft)**
- Operating temperature -35°C to +75°C (-31°F to +167°F)
- Discharge duties only
- Typical bend radius of 12D



A durable and robust hose

The Linatex® 806 soft wall slurry hose is a durable, non-wire hose construction manufactured specifically for discharge applications. The construction allows for flexibility under pressure and removes the risk of permanent deformation that may occur through mishandling or over-flexing of the hose. The robust design delivers performance and reliability in the most arduous of mining applications and protects your site asset from early failure due to external damage.

We understand that each of our customers has unique and specific requirements, so each of our hoses is custom manufactured to suit the duty at hand. Our flexible design and manufacturing versatility allows us to provide customised internal diameters, lengths, design pressures, and end coupling arrangements.

Typical Physical Properties

NOMINAL BORE		TYPICAL WEAR LINER THICKNESS		WORKING PRESSURE	BEND RADIUS	
mm	in	mm	in	kPa	mm	ft
50	2	6	¼	Atmospheric Pressure to 5000 kPa	600	1.97
80	3	6	¼		900	2.95
100	4	6	¼		1200	3.94
125	5	6	¼		1500	4.92
150	6	6	¼		1800	5.91
200	8	6	¼		2400	7.87
250	10	10	⅜		3000	9.84
300	12	10	⅜		3600	11.81
350	14	10	⅜		4200	13.78
400	16	12	½		4800	15.75
450	18	12	½		5400	17.72
500	20	12	½		6000	19.69
600	24	12	½	7200	23.62	

Note: * Custom internal diameters are also available.

** Product specifications are subject to regional variations.

Linatex® Adaptable Slurry Hose (888)

Technical Specifications

Design Features

- Adaptable open ended design for installation flexibility
- Inbuilt flange on one side only, open ended the other for trimming to length in-situ
- Swivel slotted flange design supports multiple drill patterns
- Aluminium couplings are interchangeable with the Linatex® 801 hose range
- Linatex® premium rubber internal wear liner

Applications

Pumping and transfer of abrasive slurries under pressure or vacuum in:

- Mineral processing plants
- Sand and gravel industries
- Dewatering duties
- Lime transfer

Properties

- Nominal bores from 100mm (4") to 300mm (12")*
- Operating pressures up to 1000 kPa**
- Operating temperature -35°C to +75°C (-31°F to +167°F)
- Locally available in standard lengths
- Minimum bend radius of 8D
- Safety Factor: 3:1

Versatility without compromise

The Linatex® 888 adaptable slurry hose is a hybrid design. It's inbuilt flange allows ease of assembly, while it's versatile cut-to-length feature allows the hose to be trimmed in-situ on site. The hose internal wear liner includes our Linatex® premium rubber for performance and reliability in fine slurry abrasion providing a total hose solution that supports flexibility with infield fit-up.

The hose is available in standard dimensions although may be customised to support various lengths or internal wear liner options.

Typical Physical Properties

NOMINAL BORE		NOMINAL OD		LINER THICKNESS		WEAR LINER TYPE	MAX WP		VACUUM RATING
mm	in	mm	in	mm	in		kPa	psi	%
100	4	127	5.2	6	¼	Linatex®	1000	145	90
125	5	156	6.2	6	¼	Linatex®	1000	145	90
150	6	182	7.2	6	¼	Linatex®	1000	145	90
200	8	238	9.2	6	¼	Linatex®	1000	145	90
250	10	288	11.3	6	¼	Linatex®	1000	145	70
300	12	342	13.5	6	¼	Linatex®	1000	145	70

Note: * Custom internal diameters are also available.

** Product specifications are subject to regional variations.



Linatex® Corrugated Cut End Hose & Couplings (800)

Technical Specifications

Design Features

- Corrugated cover for additional flexibility, designed for suction and delivery
- Versatile design allows for the hose to be cut to length on site
- Reusable split cast couplings bolt together to create a reusable flange connection
- Linatex® premium rubber lined for dependable performance

Applications

The Linatex® 800 corrugated cut end hose is an extremely versatile system and is extensively used in:

- Mineral processing plants
- Sand and gravel industries
- Dewatering duties
- General material handling

Properties

- Nominal bores from 50mm (2") to 350mm (14")*
- Working pressure rated to 1038 kPa (150 PSI)
- Safety factor of 3:1
- Operating temperature -30°C to +75°C (-22°F to +167°F)
- Locally stocked in standard lengths
- Minimum bend radius of 8 times the internal diameter



Exceptional abrasion resistance

The Linatex® 800 corrugated cut end hose and coupling system is an exceptionally abrasion resistant material handling hose suitable for suction and delivery applications. This versatile hose system allows the hose to be cut to the required length and fitted with our reusable couplings on site.

The Linatex® 800 hose range is readily stocked in common industry sizes and available in standard lengths, and is supported by our in-house range of bolt-on split cast couplings to create an economical ready-made hose solution.

Typical Physical Properties

NOMINAL BORE		TUBE THICKNESS		BEND RADIUS		WEIGHT		VACUUM HG		WP	COUPLING WEIGHT PER HOSE END	
mm	in	mm	in	mm	in	kg/m	lbs/ft	mm	in	psi	kg	lbs
50	2	3	1/8	406	16	2.4	1.6	762.0	30	150	1.36	3
80	3	6	1/4	610	24	6.1	4.1	762.0	30	150	2.04	4.5
100	4	6	1/4	813	32	7.3	4.9	635.0	25	150	3.18	7
150	6	10	3/8	1219	48	12.5	8.4	762.0	30	150	4.99	11
200	8	10	3/8	1626	64	19.2	12.9	558.8	22	150	7.71	17
250	10	10	3/8	2032	80	29.8	20	762.0	30	150	11.79	26
300	12	10	3/8	2438	96	34.5	23.2	406.4	16	150	14.97	33
350	14	10	3/8	2845	112	40.8	27.4	279.4	11	150	18.60	41

Note: * Product specifications are subject to regional variations.

Linatex® Smooth Cut End Hose & Couplings (801)

Technical Specifications

Design Features

- Versatile design allows for the hose to be cut to length on site
- Coupling design supports multiple flange drill patterns
- High tensile textile cords with embedded steel wire helix wires
- Available in Linatex® premium rubber or SBR internal wear liner formats

Applications

A general purpose mining hose for material handling and slurry transfer applications:

- Mineral processing plant duties
- Sand and gravel transfer
- Dewatering duties
- General material handling

Properties

- Nominal bores from 50mm (2") to 600mm (24")*
- Locally stocked in standard lengths
- Operating temperature -30°C to +75°C (-22°F to +167°F)
- Minimum bend radius of 8 times the internal diameter
- Safety factor of 3:1
- Bolt-on split cast flanges suit regional drill pattern requirements



Economical and adaptable

The Linatex® 801 smooth cut end hose and coupling system is a cost effective and versatile mine hose solution. It's expertly designed for site fit-up to support light slurry transfer and material handling duties. The 801 hose range is locally stocked in common industry sizes and is designed to suit the bolt-on split cast couplings to create an economical ready-made hose solution.

Typical Physical Properties - Cut End Hose

IN		OD		LINER THICKNESS		WEIGHT		VACUUM RATING
mm	in	mm	in	mm	in	kg	lbs	%
50	2	70	2.9	6	¼	2.6	5.7	90
80	3	105	4.1	6	¼	5.0	11.0	90
100	4	132	5.2	6	¼	7.5	16.4	90
125	5	157	6.2	6	¼	8.9	19.5	90
150	6	184	7.2	6	¼	11.4	25.1	90
200	8	233	9.2	6	¼	14.9	32.9	90
250	10	286	11.3	6	¼	21.9	48.3	70
300	12	344	13.5	6	¼	31.8	70.2	70
350	14	406	16.0	9	⅜	36.3	80.0	70
400	16	456	18.0	6	¼	54.0	119.0	70

Typical Physical Properties - Couplings

ID		LENGTH		WEIGHT	
mm	in	mm	in	kg	lbs
50	2	90	3.5	1.5	3.3
80	3	90	3.5	2	4.4
100	4	145	5.7	4.5	9.9
125	5	157	6.2	5	11.0
150	6	167	6.6	7	15.4
200	8	232	9.1	10	22.0
250	10	270	10.6	18	39.7
300	12	330	13.0	25	55.1
350	14	377	14.8	27	59.5
400	16	400	15.7	50	110.2

Note: * Product specifications are subject to regional variations.

Linatex® Acid/Chemical Hose (700)

Technical Specifications

Design Features

- Tailored designs for abrasive and corrosive acid/chemical applications
- Manufactured with a broad range of flange materials to suit the application
- High tensile reinforcement with a steel wire helix

Applications

Pumping and transfer of abrasive and corrosive acids/chemicals for:

- Acid or alkaline leach circuits at atmospheric or pressure
- Effluent plants
- Fertiliser plants
- Pulp and paper plants

Properties

- Nominal bores from 50mm (2") to 1000mm (40")*
- Lengths up to 15m (50ft)**
- Operating temperature -35°C to +105°C (-31°F to +221°F)
- Suction and discharge applications
- Compounds include SBR, OSR, Neoprene, EPDM, and Chlorobutyl liner options
- Typical bend radius of 8 times the internal diameter

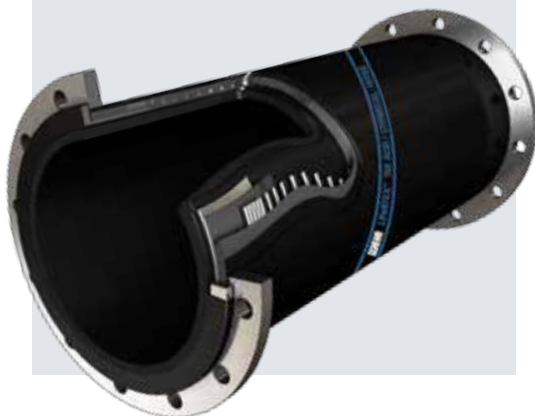

Customised abrasion and corrosion resistance

The Linatex® 700 acid/chemical hose is tailor-made to handle abrasive acid and chemical process applications. Our in-house Linatex® Rubber Technical Consultants have the expertise to deliver the best design for every application or duty.

Each hose is individually designed to suit the specific process parameters with every element of the hose construction able to be customised. This ensures it delivers prolonged performance and reliability in handling these aggressive fluids.

The hose design is constructed through a hot-vulcanisation process and is available as a suction-delivery or delivery only design. The inbuilt end connection options include fixed or swivel flanges, with swivel flanges available in a range of materials including super duplex, stainless steel or our standard carbon steel offering.

Typical Physical Properties

NOMINAL BORE		TYPICAL WEAR LINER THICKNESS		WORKING PRESSURE	BEND RADIUS	
mm	in	mm	in	kPa	mm	ft
50	2	6	¼	Atmospheric Pressure to 5000 kPa	400	1.31
75	3	6	¼		600	1.97
100	4	6	¼		800	2.62
125	5	6	¼		1000	3.28
150	6	6	¼		1200	3.94
200	8	6	¼		1600	5.25
250	10	10	⅜		2000	6.56
300	12	10	⅜		2400	7.87
350	14	10	⅜		2800	9.19
400	16	12	½		3200	10.50
450	18	12	½		4050	13.29
500	20	12	½		5000	16.40
600	24	12	½		7200	23.62

Note: * Custom internal diameters are also available.

** Product specifications are subject to regional variations.

Linatex® Slurry Hose Reducers

Technical Specifications

Design Features

- Available in a large range of sizes and reduction factors
- Matched to pump inlet and discharge internal diameters
- Superior alignment and vibration compensation
- Ease of installation

Applications

To support alignment with the intake and discharge of pumps for the transfer of wet slurries in:

- Mineral processing plants
- Acid or alkaline leach circuits
- Oil Sands plants
- Sand and gravel plants

Properties

- Nominal bores from 50mm (2") to 915mm (36")*
- Lengths from 300mm (1ft), customised to requirement**
- Operating temperature -35°C to +75°C (-31°F to +167°F)
- May be designed for suction or discharge applications
- Available with a broad array of Linatex® rubber compounds

Prolonged performance and reliability

Linatex® slurry hose reducers are designed to absorb transmitted vibration and noise between pumps, sumps and associated equipment. They are designed to support smooth transition of flow between pipework and slurry pump intake and discharge connections through either eccentric or concentric reducer configurations.

Internal diameter alignment is critical in achieving prolonged performance and reliability, and together with our world renowned wear resistant Linatex® rubber compounds we aim to provide best-in-field performance at the lowest cost of ownership. We do this by using the best quality natural rubber and processing it with leading edge technology. It is our unique, proprietary manufacturing process that gives Linatex® premium rubber its extraordinary physical properties and outstanding performance.

The slurry hose reducer range is custom manufactured to length with in-built flange options to bolt directly to pump intake or discharge flange faces. Every aspect of the reducers' design may be modified to accommodate the duty at hand, including the internal diameter, length, operating pressure, and wear lining compound and thickness. We are also able to incorporate scuttle ports and flushing points into the design to support drainage or flushing of the pipeline.

Note: * Custom internal diameters are also available.

** Product specifications are subject to regional variations.



Linatex® Dredge Flex Hose (1000)

Technical Specifications

Design Features

- Heavy duty robust construction designed to handle large dredged particles
- Hoop ring or spring wire helix construction for flexibility or full vacuum during service
- Tailor made designs, including self-floater, suction dredge hose and flexible discharge hoses
- Suitable for slurries containing rock, shell and coral

Applications

Custom designed and tailored solutions ideal for:

- Gimbal or Trunnion hoses for hopper or suction cutter dredges
- Self-floater and flexible delivery hoses and sleeves for dredge lines
- Bow connection hoses for transfer from dredge and hopper
- Jetwater hoses on trunnion suction pipes
- Hose bends in dredge pump discharge

Properties

- Nominal bores from 150mm (6") to 1200mm (47")*
- Lengths up to 11.8 metres (38ft)
- Working pressures up to 20 bar
- Safety factor of 4:1
- Flange options include fixed, swivel, double flange and built in nipple designs

Heavy duty reliability

The Linatex® 1000 dredge flex hose range is designed to perform and provide outstanding reliability in the most extreme working environments. Tailor-made designs are custom produced to meet your unique needs. The hose's heavy duty construction reliably handles harsh dredging environments and each hose is designed for the specific application.

Engineered hoop hose construction is designed for maximum flexibility under vacuum conditions and incorporates fixed or double flanges to cater for high loads upon flexing. On the discharge line, the product offering ranges from short flexible dredge sleeves or flanged hoses that allow for flexibility between piping through to complete hose discharge lines.

The discharge lines may be supplied as self-floater designs that incorporate an in-built high density foam to support flotation, through to long length discharge hoses that are constructed to be supported by external polyurethane hose collars or pontoons.



Note: * Custom internal diameters are also available.





Minerals

www.minerals.weir
info.minerals@mail.weir

