

## ALLROUNDER 370/420 C

Technical data

**Tie bar distances: 370 x 370 mm, 420 x 420 mm**

**Clamping forces: 600, 800, 1000 kN**

**Injection units (according to EUROMAP): 100, 250, 350**

**ARBURG**

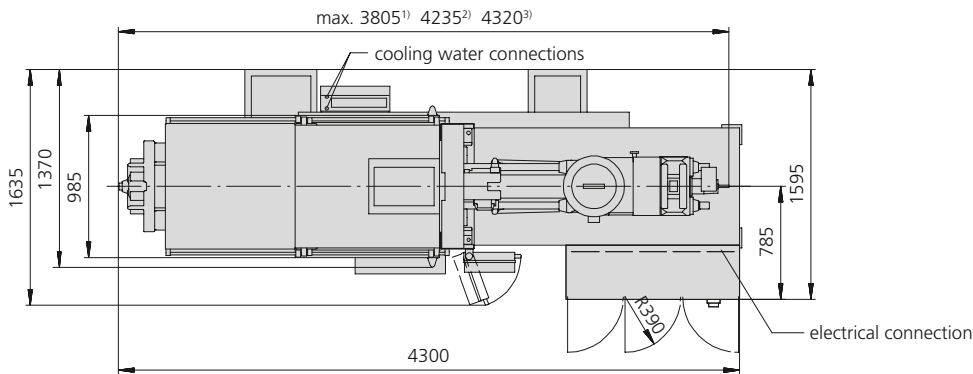
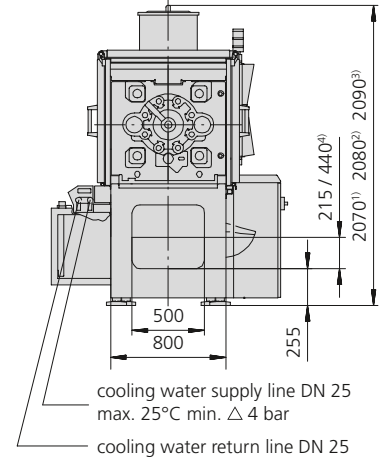
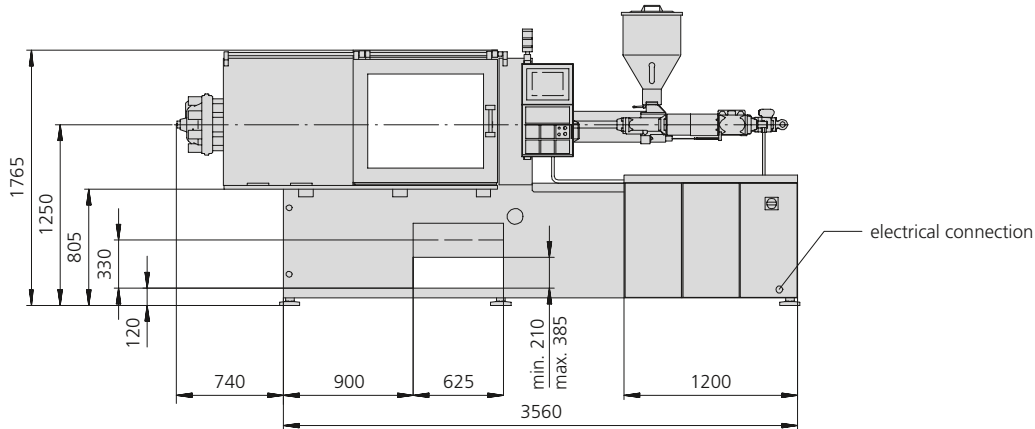

- 1) Dimensions are valid for injection unit 100
- 2) Dimensions are valid for injection unit 250
- 3) Dimensions are valid for injection unit 350
- 4) Dimension only valid in conjunction with conveyor belt

Machine model		370 C	370 C	370 C / 420 C	420 C	420 C
EUROMAP size indication <sup>1)</sup>		600-100	600-250	800-250	1000-250	1000-350
<b>Clamping unit</b>						
Clamping force	max. kN	600	600	800	1000	1000
Closing force	max. kN	50	50	50	50	50
Opening force / increased	max. kN	35 / 250	35 / 250	35 / 250	35 / 250	35 / 250
Opening stroke	max. mm	500	500	500	500	500
Mould height	min. mm	250	250	250	250	250
Daylight	max. mm	750	750	750	750	750
Distance between tie bars	mm	370 x 370	370 x 370	370 x 370 / 420 x 420	420 x 420	420 x 420
Platen size (hor. x vert.)	mm	570 x 570	570 x 570	570 x 570	570 x 570	570 x 570
Weight of mov. mould half	max. kg	600	600	600	600	600
Ejector force	max. kN	40	40	40	40	40
Ejector stroke	max. mm	175	175	175	175	175
<b>Hydraulics, drive, general</b>						
Drive power of the hydraulic pump	kW	11	15	15	18,5	22
Dry cycle time for opening stroke <sup>3)</sup>	s-mm	1,8 (1,6)-259	1,8 (1,6)-259	1,8 (1,7)-259   1,9 (1,8)-294	2,0 (1,7)-294	2,0 (1,6)-294
Total connected load <sup>2)</sup>	kW	18,4	23,9	23,9	27,4	33,9
Colour: plastic coated, structure light grey / mint green / canary yellow						
<b>Control cabinet</b>						
Safety standard according to		DIN EN 60204	DIN EN 60204	DIN EN 60204	DIN EN 60204	DIN EN 60204
Socket combination (1 single phase, 1 three-phase)		1 x 16 A	1 x 16 A	1 x 16 A	1 x 16 A	1 x 16 A
<b>Injection unit</b>						
		100	250	250	250	350
Screw diameter	mm	20 / 25 / 30	30 / 35 / 40	30 / 35 / 40	30 / 35 / 40	35 / 40 / 45
Effective screw length	L/D	25 / 20 / 16,7	23,3 / 20 / 17,5	23,3 / 20 / 17,5	23,3 / 20 / 17,5	23 / 20 / 18
Screw stroke	max. mm	100	150	150	150	145
Calculated injection volume	max. cm <sup>3</sup>	31 / 49 / 71	106 / 144 / 188	106 / 144 / 188	106 / 144 / 188	139 / 182 / 230
Shot capacity	max. g PS	29 / 45 / 65	97 / 132 / 172	97 / 132 / 172	97 / 132 / 172	127 / 166 / 210
Material throughput <sup>6)</sup>	max. kg/h PS	5,5 / 8 / 9,5	17 / 20,5 / 24,5	17 / 20,5 / 24,5	17 / 20,5 / 24,5	25 / 29 / 35
	max. kg/h PA 6.6	2,8 / 4 / 4,9	8,5 / 10,5 / 12,5	8,5 / 10,5 / 12,5	8,5 / 10,5 / 12,5	12,5 / 15 / 17,5
Injection pressure <sup>5)</sup>	max. bar	2500 / 2240 / 1550	2470 / 1820 / 1390	2470 / 1820 / 1390	2470 / 1820 / 1390	2500 / 2120 / 1670
Injection flow <sup>3)</sup>	max. cm <sup>3</sup> /s	80 / 124 / 180	112 / 154 / 202	112 / 154 / 202	144 / 196 / 256	128 / 168 / 212
Injection flow with accumulator	max. cm <sup>3</sup> /s	160 / 250 / 362	350 / 476 / 622	350 / 476 / 622	350 / 476 / 622	492 / 642 / 814
Back pressure positive / negative	max. bar	350 / 200	350 / 140	350 / 140	350 / 140	350 / 160
Circumferential screw speed	max. m/min	42 / 52 / 63	49 / 57 / 66	49 / 57 / 66	49 / 58 / 66	47 / 53 / 60
Screw torque	max. Nm	120 / 150 / 180	320 / 380 / 430	320 / 380 / 430	320 / 380 / 430	480 / 550 / 610
Nozzle contact force	max. kN	50	60	60	60	60
Nozzle retraction stroke	max. mm	180	240	240	240	300
Installed cylinder heating power / heating zones	kW	4,3 / 4	5,8 / 4	5,8 / 4	5,8 / 4	8,8 / 4
Installed nozzle heating power	kW	0,6	0,6	0,6	0,6	0,6
Material hopper capacity	l	50	50	50	50	50
Horizontal injection position <sup>4)</sup>	max. mm	170 (120)	170 (120)	170 (120)	170 (120)	170 (120)
<b>Machine dimensions and weights of the basic machine</b>						
Oil capacity	l	235	235	235	235	235
Net weight	kg	3370	3450	3450	3460	3700
Electrical connection (pre-fused) <sup>2)</sup>	A	63	80	80	100	100

1) 1st figure: clamping force (kN), 2nd figure: max. dosage volume (cm<sup>3</sup>) x max. injection pressure (kbar)

2) Values refer to 400 V/50 Hz. The load is symmetrically distributed on three phases. The specified value applies to the basic machine.

The connection value can be increased by additional options which may make 2 separate supply lines necessary (motor + controller/heating)

3) According to EUROMAP for the basic machine. Values shown in parentheses apply for dual-pump technology.

4) Measurement in brackets valid in connection with MULTILIFT H

5) A combination of max. injection pressure and max injection flow (max. injection capacity) can be mutually exclusive, depending on the equipment-related motor output

6) Deviations are possible depending upon process settings and material type

These technical data specifications refer to the state at the time of printing. We reserve the right to modify specifications in the interest of a continuous program of further development.

### Control system and control cabinet

- SELOGICA control system (modular, graphic multi-processor system)
- Available in different language versions
- Language change
- Cycle sequence programming with symbols
- Cycle step display in sequence diagram
- Cycle time diagram
- Swivelling monitor unit, central on the operator's side, with colour monitor
- Process graphics for injection speed, screw stroke and injection pressure
- Quality assurance program with fault evaluation and monitoring chart
- Optimisation and user help, follow-up functions at program end, for freely programmable parameter pages, selectable units
- Modular control cabinet design with self-recognition of plug in circuit board system
- Operating modes:
  - Set up
  - Freely programmed test run
  - Reconfiguration
  - Automatic purging and dosing
- Equipment for switch-over to holding pressure via injection pressure, material pressure with different pressure transducers, or via external switch over signal
- Data set administration via diskette
- Visual warning signal (warning lamp)
- Visual / audible warning signal (flashing light / siren)
- Serial printer interface for hard copy, data record and quality protocol
- Interfaces for: PC keyboard, plotter, robotic system according to EUROMAP 12 or 67, part weighing scale, optical barrier, host processor, AQC, ALLROUNDER@web, colouring unit, LSR dos-

- ing system, INJESTER, container change, wiper unit (brush), THERMOLIFT, hot runner control unit and temperature control units for moulds and cylinder
- Socket combination 1 CEE, 1 Schuko 230 V
- Socket combination 1 CEE, 1 Schuko or 3 CEE, 3 Schuko 230 V with external supply line
- 1 additional heating regulation circuit for the nozzle
- Electric heating regulation circuits for moulds (adaptive) (3, 6, 9, 12, 15, 18); mould heating fused at 10 A
- Fuses for mould heating 16 A
- 4 or 8 freely programmable inputs / outputs
- Core pull programs in many versions integrated in the SELOGICA control system
- Special processes such as injection coining, mould venting, varioterm temperature control, intruding, marbling
- Monitoring: Freely-programmable position monitoring
- Many individual options for special processes

### Machine base and hydraulic system

- Free standing machine base on anti-vibration pads
- Ergonomic protection cover with free access to mould and nozzle
- Space for peripheral devices within floor space
- The hydraulic system operates with an energy-saving variable displacement pump and a servo valve for pressure and speed regulation
- Expansion to up to 2 hydraulic control circuits
- Expansion to up to 3 hydraulic control circuits
- ARBURG energy saving system AES (rpm changeable for hydraulic pump drive)
- Minimum oil volume, oil change interval every 20,000 hours

- Monitoring of oil level, oil temperature and oil filter contamination
- Fine mesh oil filter in the return line
- Mechanical regulation of hydraulic oil temperature
- Electronic regulation of hydraulic oil temperature. Display and monitoring via screen
- Hydraulic oil preheating program to reduce start-up time
- Separate, continuous oil circulation for additional cooling and filtration
- Manually adjustable, machine-related cooling water circuits with 4 free mould connections
- 6 or 8 free cooling water circuits, manually adjustable
- Programmable, machine and mould-related cooling water circuits
- 1 or 2 central switch-off valves for cooling water
- Conveyor belt (electrically driven), height-adjustable in 3 steps, can be integrated into the machine base with or without sorter unit
- Crane with electric hoist to facilitate mould installation and to swivel or shift the injection unit

### Clamping unit

- Centrally applied, fully-hydraulic clamping system with 4 individually-removable tie bars
- Vertical support of the movable mould platens
- Movement profiles for the mould clamping unit are programmable and regulated. They are serially driven using energy-saving one-circuit pump technology (Technology stage 1)
- Movement profiles for the mould clamping unit are programmable and regulated. They are driven using two-circuit pump technology (Technology stage 2 - servo-regulated). The closing pressure is regulated. Simultaneous movement of nozzle and ejector is possible

- Hydraulic system with 3 regulating pumps for extended simultaneous movements (T3)
- Closing and opening profiles are 2-stage programmable (4-stage with Technology stage 2)
- Intermediate stop possible when closing and opening (standard with T2)
- Regulated hydraulic mould protection with monitoring of mould protection time. Follow-up functions: Open or stop after 1 or 2 activations of mould protection
- Extended mould protection (e.g. for spring loaded moulds). Freely-programmable start and end
- Automatic ramp control during switch-over to a lower speed and during stopping of a movement function
- Hydraulic ejector with quick release coupling is integrated into the clamping system
- Hydraulic ejector: Forces and speeds, multiple stroke (up to 10) and ejector advanced at program end are programmable
- Hydraulic ejector for simultaneous movements regulated with servo valve
- Mould monitoring via ejector platen safety switch
- Electro-mechanical servo drive for ejector system, position controlled for simultaneous drive movements
- Hydraulic core pulls with rapid connect coupling on the movable mould platen
- Hydraulic core pull movement profiles programmable and regulated
- Core holding pressure manually adjustable
- Pressure hold programmable
- Hydraulic core pull, simultaneous movements regulated
- Controlled hydraulic unscrewing units for threaded cores in one or two directions of rotation for mounting on fixed or movable clamping platen. Restricted ejector stroke

- Unscrewing unit with electro-mechanical servo drive for 2-direction threaded cores for installation on the movable clamping platen for ultra-precise positioning and reproducibility. Restricted ejector stroke
- Attachment option for robotic handling device
- Mechanical rapid clamping system with mould support to facilitate mould installation
- Power-operated safety gate, programmable opening time
- Mould blow unit with pressure relief valve
- Sorter unit (SELECTRON)
- Mechanical mould closing protection

## Injection unit

- Central injection unit, can be re-positioned and swivelled as a complete assembly
- Horizontally displaceable injection unit (VARIO principle)
- Adapter for parting line injection
- Plasticising module with universal screw, central coupling and adaptive temperature regulation, available in different diameters
- Thermoplastic cylinder with universal screw in wear resistant execution
- Thermoplastic cylinder complete with very high wear resistant equipment
- Plasticising module for processing thermoset, elastomer and silicone materials
- Thermoplast screws for special applications, e.g. self-dyeing (mixing section), PVC (shear-sensitive), POM, PA (semi-crystalline)
- Programmable nozzle speeds (advance 2, retract 1 stage) and advance and retract delay
- Monitored nozzle contact
- Continuous nozzle contact during the complete cycle
- Programmable nozzle contact force
- Regulated nozzle contact force

- Regulated injection speed profile, 2 steps programmable with injection delay
- Pressure accumulator for very fast injection
- Position-regulated screw (forced movement of injection axis)
- Injection process control with external sensor
- Measurement, display and monitoring of the injection time, switchover volume and switchover pressure
- Switch over to holding pressure as a volume or time dependent function
- Material cushion monitoring
- Holding pressure profile regulated via polygon with 4 base points
- Programmable delay times for all movements
- Screw circumferential speed display
- Positively and negatively programmable back pressure
- Dosage time display with programmable dosage time monitoring
- Dosage possible before or after nozzle retraction
- Material decompression with programmable decompression speed
- Dosage with electro-mechanical servo drive, energy-saving
- Open nozzle with screw-in tip
- Needle type shut off nozzle, spring force actuated
- Needle type shut off nozzle, hydraulically actuated
- Zone-dependent monitoring of heating circuits for continuity, short circuit and defective sensors
- Temperature monitoring with release tolerance range and zone-dependent monitoring tolerance
- Automatic temperature sink can be selected on error or after automatic switch off
- 50 litre corrosion proof stainless steel material hopper movable to a blocking and emptying position
- Granulate feed zone, programmable and regulated with monitoring

## Extended functions

- Extended monitoring of the mechanical sequence of mould and machine for complex applications
- Extended drive movements: Increase in number of movement stages, intermediate stop functions and extended locking force program
- Production control with nominal temperature value control, programmable alarm cycles, programmable switch-on / switch-off sequences as well as time-controlled automatic switch-on/off in second programming level for follow-up batch

## Regulated parameters

- Control cabinet temperature
- Hydraulic oil temperature
- Plasticising cylinder temperature (adaptive)
- Screw rotation speed
- Injection flow or injection speed
- Holding pressure
- Movements and force of mould, nozzle and ejector
- Ramp control sequence for mould, ejector and nozzle end position
- Back pressure
- Electrical mould heating circuits (adaptive)
- Mould cooling circuits
- Internal cavity pressure or screw chamber pressure (external sensor)
- Nozzle contact force
- Screw position
- Granulate feed zone temperature
- Ejector

## ARBURG robotic systems

- INTEGRALPICKER H: sprue picker operating horizontally from the rear of the machine under the protection cover; pneumatic drive
- INTEGRALPICKER V: vertical sprue picker operating from above, pneumatic drive
- MULTILIFT H: robotic system operating horizontally from the rear of the machine with pneumatic drives (Z-axis optional with servo-electric drive)
- MULTILIFT V: robotic system operating vertically from above (longitudinal and transverse installation possible) with 3 servo-electric axes

- Basic machine
- Options

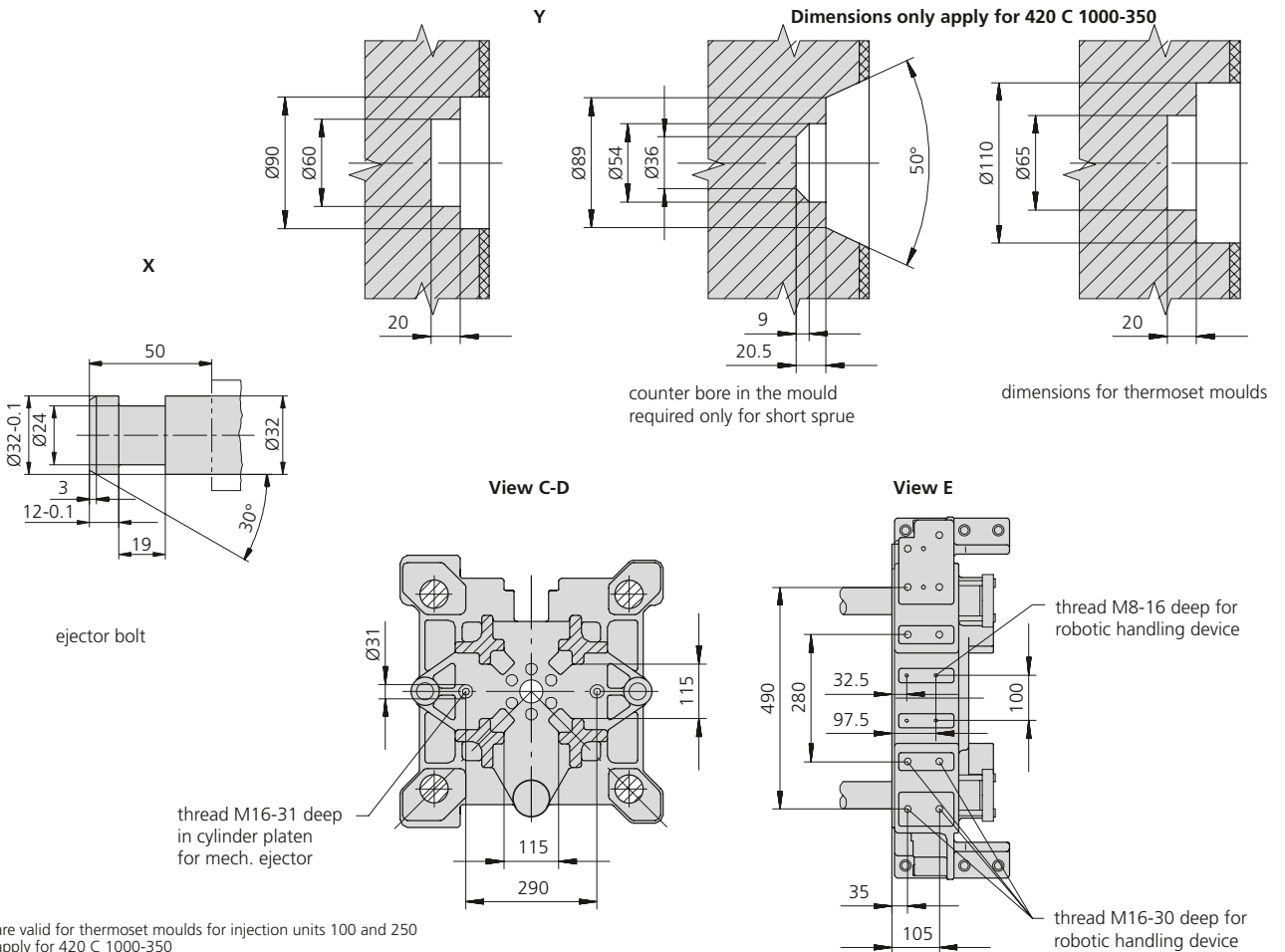
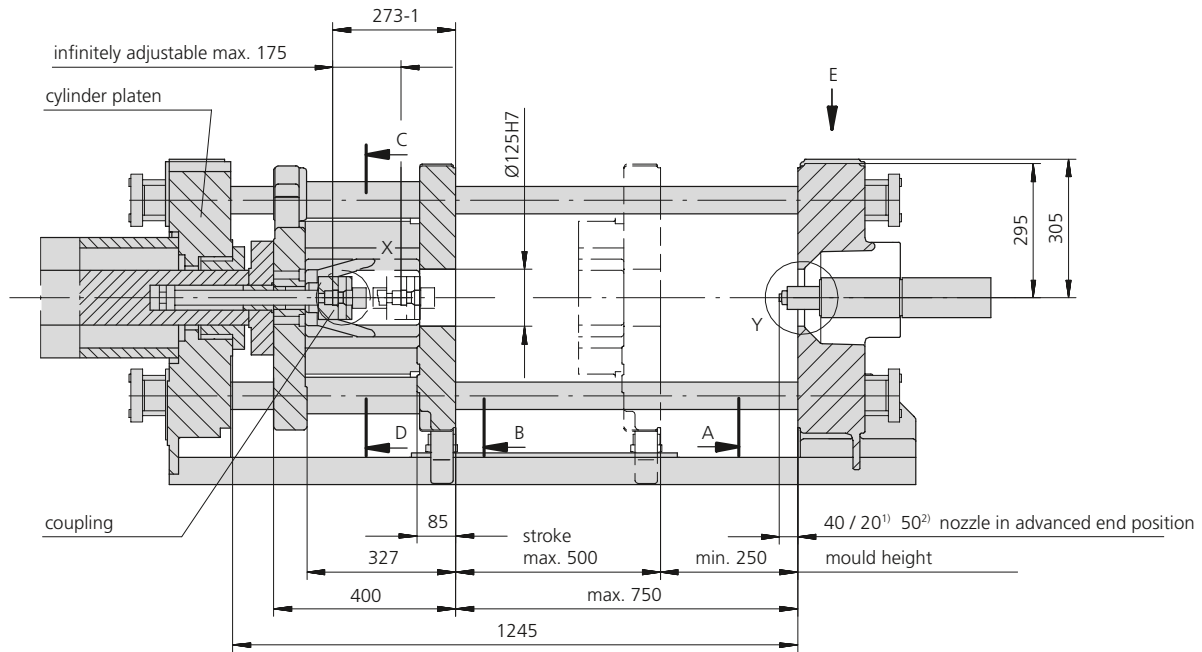

1) Dimensions are valid for thermoset moulds for injection units 100 and 250  
 2) Dimensions apply for 420 C 1000-350  
 Refer to separate dimension sheet for parting line unit (on request)

## Fixed platen

View A / for horizontally displaceable injection unit

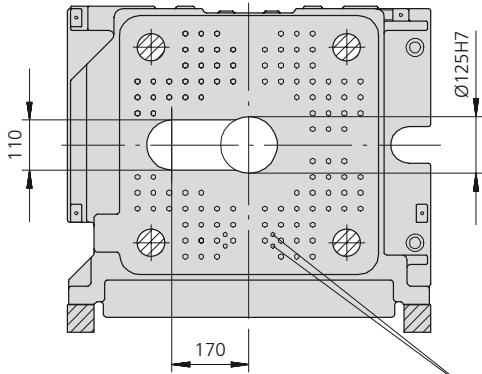

View A / for central injection unit

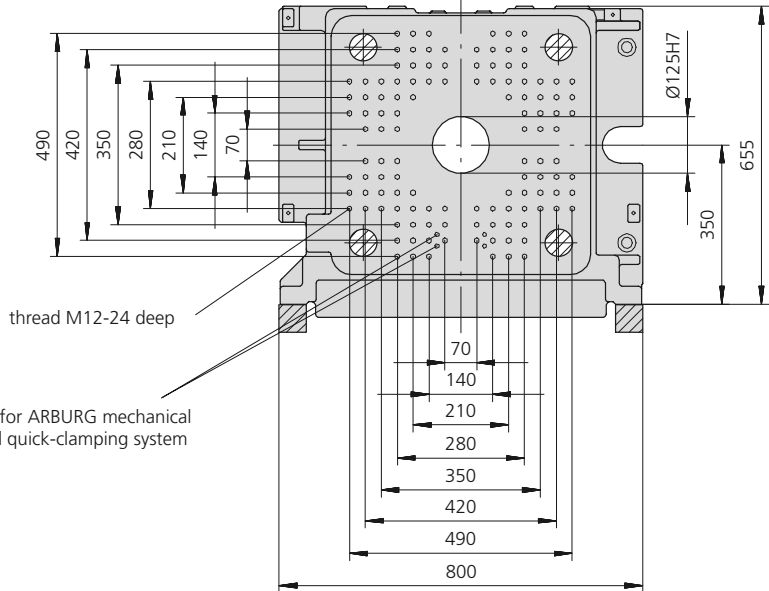

## Movable platen

View B

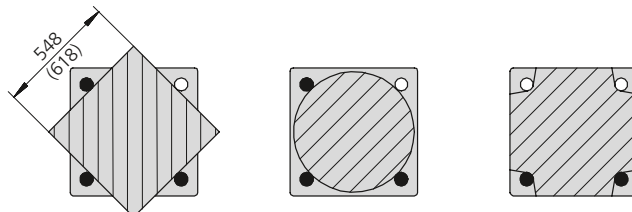
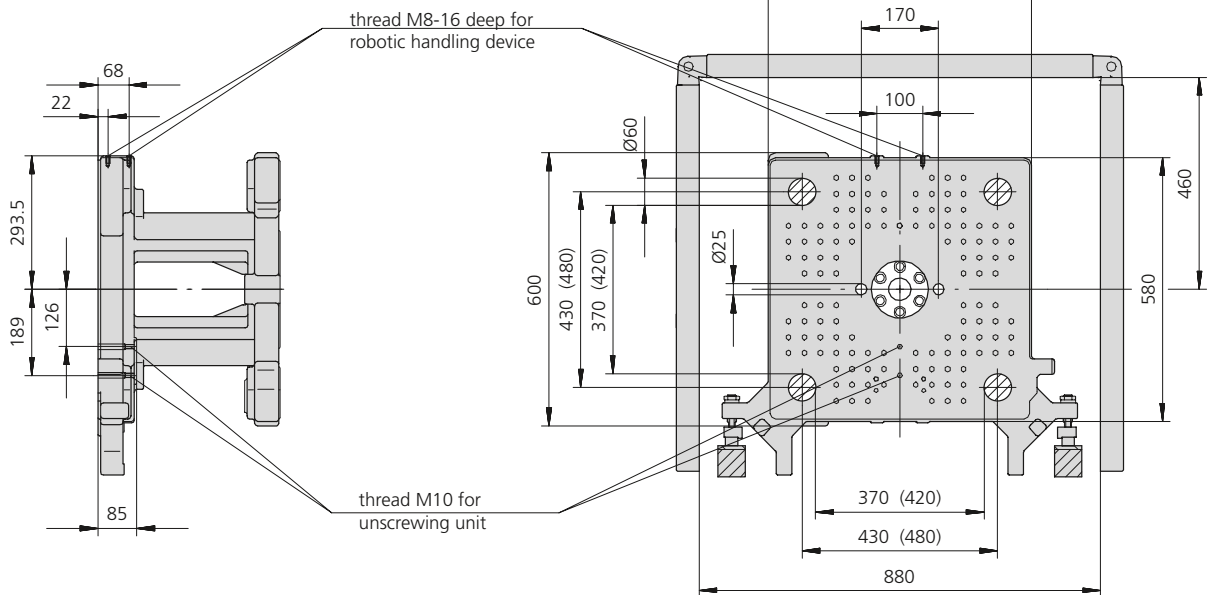

( ) Dimensions apply for 420 C

Useable mounting surface with tie bars removed

**Maximum theoretical shot weights for the most important injection moulding materials (in grams)**

Injection units according to EUROMAP		100			250			350		
Screw diameter	mm	20	25	30	30	35	40	35	40	45
Polystyrene	PS	29	45	65	97	132	172	127	166	210
Styrene heteropolymerizates	SB	28	44	63	95	129	168	124	162	205
	SAN, ABS <sup>1)</sup>	27	43	62	93	126	165	122	160	202
Cellulose acetate	CA <sup>1)</sup>	32	50	73	109	148	194	143	187	237
Celluloseacetobutyrate	CAB <sup>1)</sup>	30	47	68	101	138	180	133	174	220
Polymethyl methacrylate	PMMA	30	46	67	100	136	178	132	172	218
Polyphenylene ether, mod.	PPE	27	42	60	90	122	160	118	154	195
Polycarbonate	PC	30	47	68	102	139	181	134	175	221
Polysulphone	PSU	31	49	70	105	143	187	138	181	229
Polyamides	PA 6.6, PA 6 <sup>1)</sup>	28	44	64	96	131	171	127	165	209
	PA 6.10, PA 11 <sup>1)</sup>	26	41	60	90	122	160	118	154	195
Polyoximethylene (Polyacetal)	POM	35	55	80	120	163	213	157	205	260
Polyethylene terephthalate	PET	34	53	77	115	157	205	152	198	251
Polyethylene	PE-LD	22	34	49	73	100	130	96	126	159
	PE-HD	22	35	50	76	103	134	99	130	164
Polypropylene	PP	23	36	51	77	105	137	101	133	168
Fluoropolymerides	FEP, PFA, PCTFE <sup>1)</sup>	46	72	103	155	211	276	204	266	337
	ETFE	40	63	91	136	185	242	178	232	294
Polyvinyl chloride	PVC-U	35	54	78	117	159	208	154	201	254
	PVC-P <sup>1)</sup>	32	50	72	108	147	192	142	186	235

1) average value

**ARBURG GmbH + Co KG**

Postfach 11 09 · 72286 Lossburg · Tel.: +49(0)7446 33-0 · Fax: +49(0)7446 33-3365 · www.arburg.com · e-mail: contact@arburg.com

**With locations in | Europe:** Germany, Belgium, Denmark, France, United Kingdom, Italy, Netherlands, Austria, Poland, Switzerland, Slovakia,Spain, Czech Republic, Turkey, Hungary | **Asia:** People's Republic of China, Indonesia, Malaysia, Singapore, Thailand | **America:** Brazil, Mexico, USAFor more information, please go to [www.arburg.com](http://www.arburg.com).

© 2008 ARBURG GmbH + Co KG

The brochure is protected by copyright. Any utilisation, which is not expressly permitted under copyright legislation, requires the previous approval of ARBURG.

All data and technical information have been compiled with great care. However, we are unable to guarantee its correctness. Individual illustrations and information may deviate from the actual delivery condition of the machine. The relevant valid operating instructions are applicable for the installation and operation of the machine.

**ARBURG GmbH + Co KG Quality:**

DIN EN ISO 9001 + 14001 certified