

ProCam

DIAPHRAGM AND PLUNGER METERING PUMPS



Part of SPX Corporation (NYSE: SPW), the Flow Technology segment designs, manufactures, installs and services highly engineered solutions used to process, blend, meter and transport fluids, in addition to air and gas filtration and dehydration. The segment supports the food and beverage, dairy, pharmaceutical, oil and gas, energy, and industrial markets worldwide.

Based in Charlotte, North Carolina, SPX Corporation (NYSE: SPW) is a global Fortune 500 multi-industry manufacturing leader with over \$5 billion in annual revenue, operations in more than 35 countries and over 15,000 employees. The company's highly-specialized, engineered products and technologies are concentrated in Flow Technology and energy infrastructure. Many of SPX's innovative solutions are playing a role in helping to meet rising global demand for electricity and processed foods and beverages, particularly in emerging markets. The company's products include food processing systems for the food and beverage industry, power transformers for utility companies, and cooling systems for power plants. For more information, please visit www.spx.com.

For more than 75 years, Bran+Luebbe - now SPX Flow Technology - has been providing customers with high quality metering, processing and analysing equipment.

As part of the global SPX Corporation, we are one of the world's most reputable manufacturers of metering and process pumps, process systems as well as analyzing technologies. Our engineers have comprehensive process and applications knowledge across a wide range of markets. This has resulted in product innovations and developments which harness the latest technology whilst meeting the highest quality standards.

ProCam Metering Pumps

ProCam is an economical range of metering pumps, designed for use in many industrial or hygienic processes. The mechanically actuated diaphragm pumps offer safe and reliable operation for hazardous liquids with a plunger pump head option for high pressure, low flow duties. The pumps are suitable for single & multi-stream processes and auto-control using variable speed, electric stroke or a combination of both.

THE IDEAL MODEL FOR A WIDE RANGE OF APPLICATIONS

SAMPLES OF EXECUTED PUMPS



PROCAM PLUNGER METERING PUMPS	PAGE	4 - 5
PROCAM DIAPHRAGM METERING PUMPS	PAGE	6 - 7
PROCAM HYGIENIC	PAGE	8 - 9
PROCAM COMPACT METERING STATION	PAGE	10 - 11

Applications

CHEMICAL PROCESSING

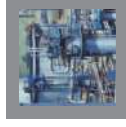

POWER & ENERGY

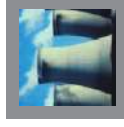

FOOD & BEVERAGE



PHARMACEUTICAL & BIOTECHNOLOGY



WATER AND WASTEWATER TREATMENT

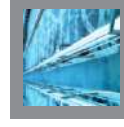

ProCam Plunger Metering Pumps



Plunger metering pump with stainless steel pump head and manual flow rate control.

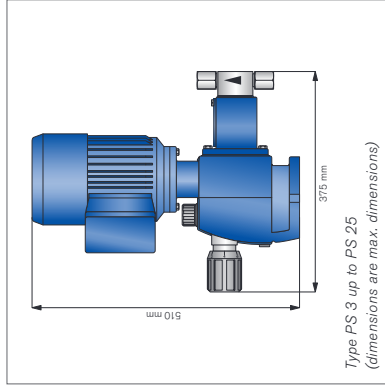

Type PS 3 up to PS 25
(dimensions are max. dimensions)

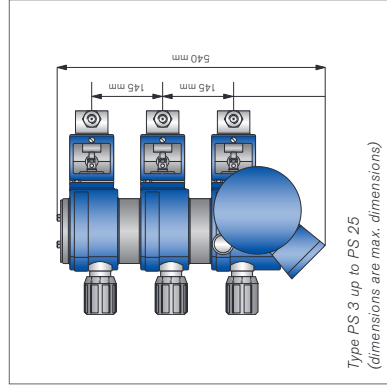

Type PS 3 up to PS 25
(dimensions are max. dimensions)

Economical and reliable, the robust and compact design of the ProCam plunger pump allows high operational security.

AT A GLANCE

- Economic metering of non-hazardous fluids
- Operating pressure up to 80 bar
- Flow rates from 0.16 to approx. 60 l/h
- Robust gear technology with proven lost motion design for continuous operation at max. flow / pressure conditions
- Linear stroke adjustment with manual or electric options
- High operational security



GENERAL

- Gear box in a rugged cast iron housing
- Integrated worm gear
- Splash lubrication
- Electric motor (IEC, IP55)

STANDARD

- Single pump with plunger pump head
- Manual stroke adjustment
- Electric motor with fixed speed
- Materials for pump head and valve housing
- Stainless steel

OPTIONS

- Multiple pumps with up to 6 plunger pump heads are available
- Can be combined with ProCam diaphragm metering pump
- Electric stroke length adjustment (also with integrated controller)
- Electric motor with variable speed
- Hazardous area design (up to Zone 1, IIC, T4)

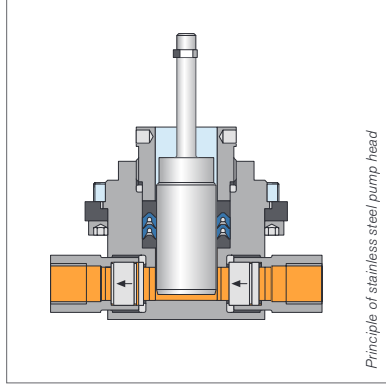

Principle of stainless steel pump head

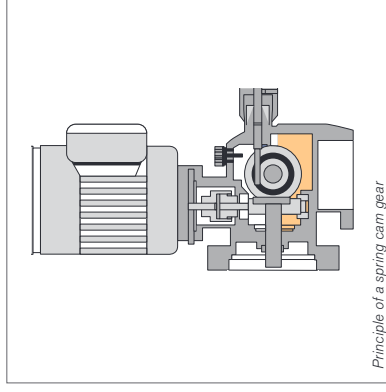

Principle of a spring cam gear

FLOW RATE AND PRESSURES

MAX. FLOW RATE (L/H)

TYPE	50	72	100	144	MAX. PRESSURE	MATERIAL IN CONTACT WITH METERED LIQUID
PS 3	0.16	0.23	0.32	0.46	80	1.4571
PS 5	0.45	0.64	0.90	1.29	80	1.4571
PS 8	1.15	1.65	2.30	3.30	80	1.4571
PS 10	3.40	4.80	6.70	9.70	80	1.4571/1.4581
PS 16	8.60	12.40	17.20	24.80	80	1.4571/1.4581
PS 25	21.00	30.20	42.00	60.40	32	1.4571/1.4581

ProCam Diaphragm Metering Pumps



Designed for operating pressures up to 20 bar and flow rates up to 3,000 l/h

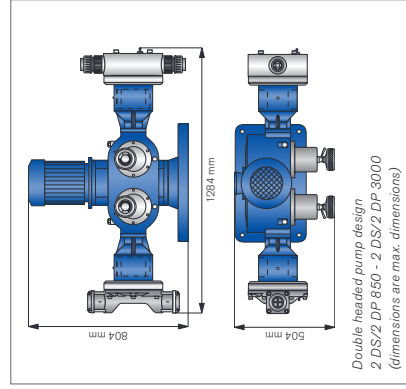
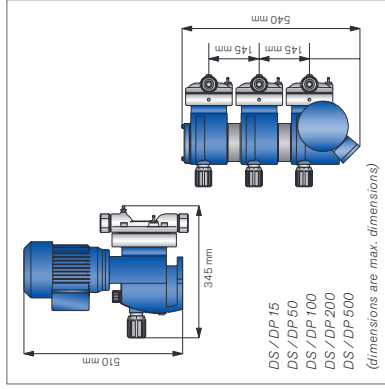

Our classic series of mechanically actuated double diaphragm pumps for low to medium range applications, brings the advantages and security of the double diaphragm concept to a wide variety of applications at an economical price.

AT A GLANCE

- Hermetically sealed pump head with mechanically operated PTFE double diaphragm allowing
 - safe metering of hazardous liquids
 - contamination free operation (important in potable water production)
- Allows economic operation without loss in operating safety and reliability
- 2 years warranty of PTFE double diaphragm
- Diaphragm condition monitoring
- Outstanding corrosion resistance due to high quality PTFE double diaphragm



GENERAL

- Gear box in a rugged cast iron housing
- Integrated worm gear
- Splash lubrication
- Electric motor (IEC, IP55)

STANDARD

- Diaphragm pump with a single pump head
- Manual stroke adjustment
- Drive with fixed speed
- Materials for pump head and valve housing
 - Stainless steel
 - PVC

OPTIONS

- Multiple pumps with up to 6 pump heads are available (valid for type DS/DP15 – DS/DP500) or 2 pump heads (valid for type DS/DP850 and DS/DP3000)
- Electric stroke length adjustment (also with integrated controller)
- Electric motor with variable speed
- Hazardous area design (up to Zone 1, IIC, T4)

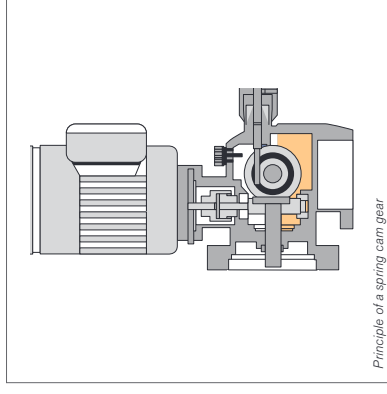
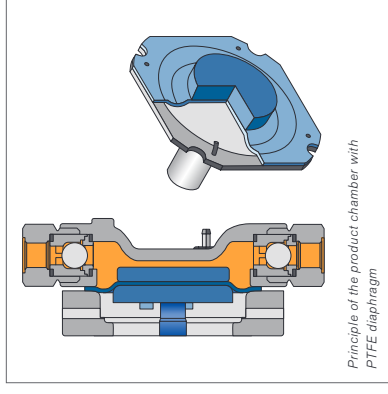

FLOW RATE AND PRESSURE

MAX. FLOW RATE (L/H)

TYPE	STROKE FREQUENCY			1 / MIN			MAX. PRESSURE*			
	50	72	100	100	144	200	100	144	200	bar
DS/DP 15	5	7,5	10	10	15	20				20
DS/DP 50	17,5	25	35	35	50	10				10
DS/DP 100	35	50	70	70	100	4				4
DS/DP 200	70	100	140	140	200	12				12
DS/DP 500	175	250	350	350	500	5				5
DS/DP 850	300	430	600	600	850	3		1200		3
DS/DP 3000	1040	1500	2080	2080	3000	5				5

* Operating pressure for plastic pump heads: 10 bar. With multiple pumps (4 - 6 heads) the max. operating pressure is only 50% of the indicated pressure.

ProCam Hygienic

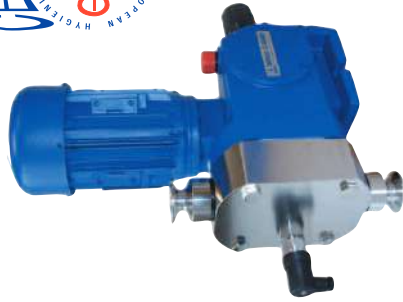

Clamp-connection and ball valve in SS316L with Ra 0.8, PTFE gaskets (FDA approved)

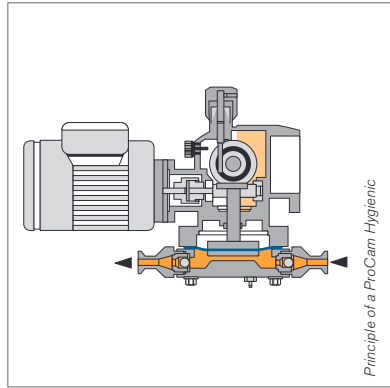

Principle of a ProCam Hygienic

Diaphragm pump EHEDG* certified – designed according to EHEDG guidelines.
 *European Hygienic Engineering and Design Group.

AT A GLANCE

- CIP (cleaning-in-place) at 83°C
- Covers requirements in hygienic and sterile applications
- Specifically designed for applications in the pharmaceutical industry, biotechnology, cosmetics, personal care, food and beverage industry
- Flexible multi-pump head design



FACTS

- Metering pump with PTFE double diaphragm (FDA approved) and diaphragm condition monitoring by pressure switch
- Hygienic valve design
- Little residence time in the product chamber of the pump head
- Double diaphragm and valve gaskets are made of PTFE (FDA)
- Coating according to FDA requirements
- Front cover, valves, connections in material SS316 L with surface roughness RA 0.8 (optional Ra 0.4)

FLOW RATE AND PRESSURES							
MAX. FLOW RATE* (L/H)		STROKE FREQUENCY 1/MIN			MAX. PRESSURE*		CONNECTIONS
TYPE		50	72	100	144	bar	
DS 15	5	5	7.5	10	15	20	½" Clamp
DS 50	17.5	17.5	25	35	50	10	½" Clamp
DS 100	35	35	50	70	100	4	½" Clamp
DS 200	70	70	100	140	200	1.2	½" Clamp
DS 500	175	175	250	350	500	5	1" Clamp

* With multiple pumps (4 – 6 heads) the max. operating pressure is only 50% of the indicated pressure.

ProCam Compact Metering Station



Compact design – based on the ProCam metering pump this is a convenient solution for chemical preparation and metering.

SOLID DESIGN

- Stable base plate for pumps up to 50 kg
- Fluid temperature up to 60°C
- Tank UV stabilised for outdoor use
- Polyethylene tank material corrosion resistant against many chemicals
- Brackets for floor mounting available

COMPLETE SOLUTION AND OPTIONS

- Tank sizes from 60 to 500 litres (or on request)
- Standard equipment includes metering pump, tank, suction pipe, inlet valve, manual stirrer and stable mounting plate for pumps
- Easy to read liquid level due to scale moulded into the tank wall
- Wide filling port with manual screw lid for easy handling

Options:

- Motor driven stirrer
- Level switches (1 or 2 contacts)
- Pressure relief valve with return to the tank
- Tank drain

SCOPE OF SUPPLY

- 1 ProCam metering pump
- 2 Tank (PE)
- 3 Base plate (PVC)
- 4 Suction pipe (PVC)
- 5 Foot valve (PVC)
- 6 Manual stirrer (PVC)
- 7 Option: Motor driven stirrer
- 8 Option: Level switches
- 9 Option: Pressure relief valve
- 10 Option: Drain
- 11 Option: 4 brackets (PE) for floor mounting

AT A GLANCE

- Chemical industry e.g. metering of additives or inhibitors
- Water treatment plants
- CIP systems in the food & beverage industry
- Applications in the galvanizing industry
- Preparation of fertilizer solutions

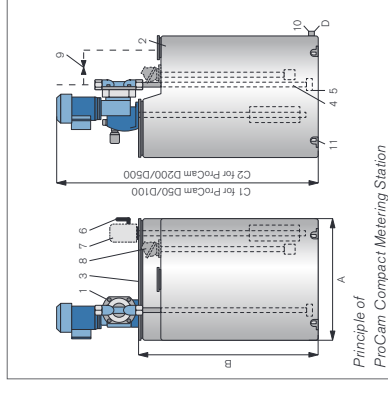

VOLUME AND DIMENSIONS

TANK	ø/A	B	C1	C2	D
60 l	450	545	925	965	1/2*
100 l	470	730	1110	1150	1/2*
200 l	610	875	1255	1295	1/2*
300 l	680	950	1330	1370	1*
500 l	830	1065	1445	1485	1*





THE PRODUCT RANGE - MORE EXAMPLES OF BRAN+LUEBBE PRODUCTS WITH HIGH QUALITY STANDARD, INNOVATION AND KNOW-HOW.



Metering pumps
for all process areas
where liquids are
metered and mixed.
NOVADOS



Process pumps
for large flow rates and
high operating pressures
NOVAPLEX
MEGANIZER
High pressure homogenizer



**Dynamic
in-line mixer**
for gentle
but intensive mixing
PENTAX
PENTAX Hygienic



Process systems
as a complete
solution for increased
productivity and quality
AutoBlend
Metering and mixing systems



Oil & Gas systems
to aid oil & gas recovery
onshore and offshore
Solar Panel Packages
Chemical Injection Systems
Flow Control Device Panels



On-line Analyzers
for use in water and
effluent treatment
PowerMon
PowerMon S
PowerMon Compact

Global locations

EMEA

SPX FLOW TECHNOLOGY

Werkstraße 4
D-22844 Norderstedt
Phone: +49 (0) 40 - 522 02 -0
Fax: +49 (0) 40 - 522 02 -444
E-Mail: branluebbe@spx.com

SPX FLOW TECHNOLOGY

Ironstone Way
Brixworth, Northants, NN6 9UD
Phone: +44 (0) 1604 880751
Fax: +44 (0) 1604 880145
E-Mail: ft.brixworth.sales@spx.com

AMERICAS

SPX FLOW TECHNOLOGY

611 Sugar Creek Road
Delavan, WI 53115 USA
Phone: +1 (800) 252-5200 or
+1 (262) 728-1900
Fax: +1 (262) 728-4904
E-Mail: branluebbe@spx.com

APAC

SPX FLOW TECHNOLOGY

25 International Business Park
#03-03/12, German Centre,
Singapore 609916
Phone: +65 6568 1568
Fax: +65 6265 9133
E-Mail: asia.pacific@spx.com

SPX FLOW TECHNOLOGY NORDERSTEDT GMBH

Werkstraße 4
D-22844 Norderstedt
Phone: +49 (0) 40 - 522 02 -0
Fax: +49 (0) 40 - 522 02 -444
E-Mail: branluebbe@spx.com

SPX reserves the right to incorporate our latest design and material changes without notice or obligation.

Design features, materials of construction and dimensional data, as described in this bulletin, are provided for your information only and should not be relied upon unless confirmed in writing. Please contact your local sales representative for product availability in your region. For more information visit www.spx.com.

"The green ">" is a trademark of SPX Corporation, Inc."