

Safety for Hydraulics Monoblock - type Proportional Valves

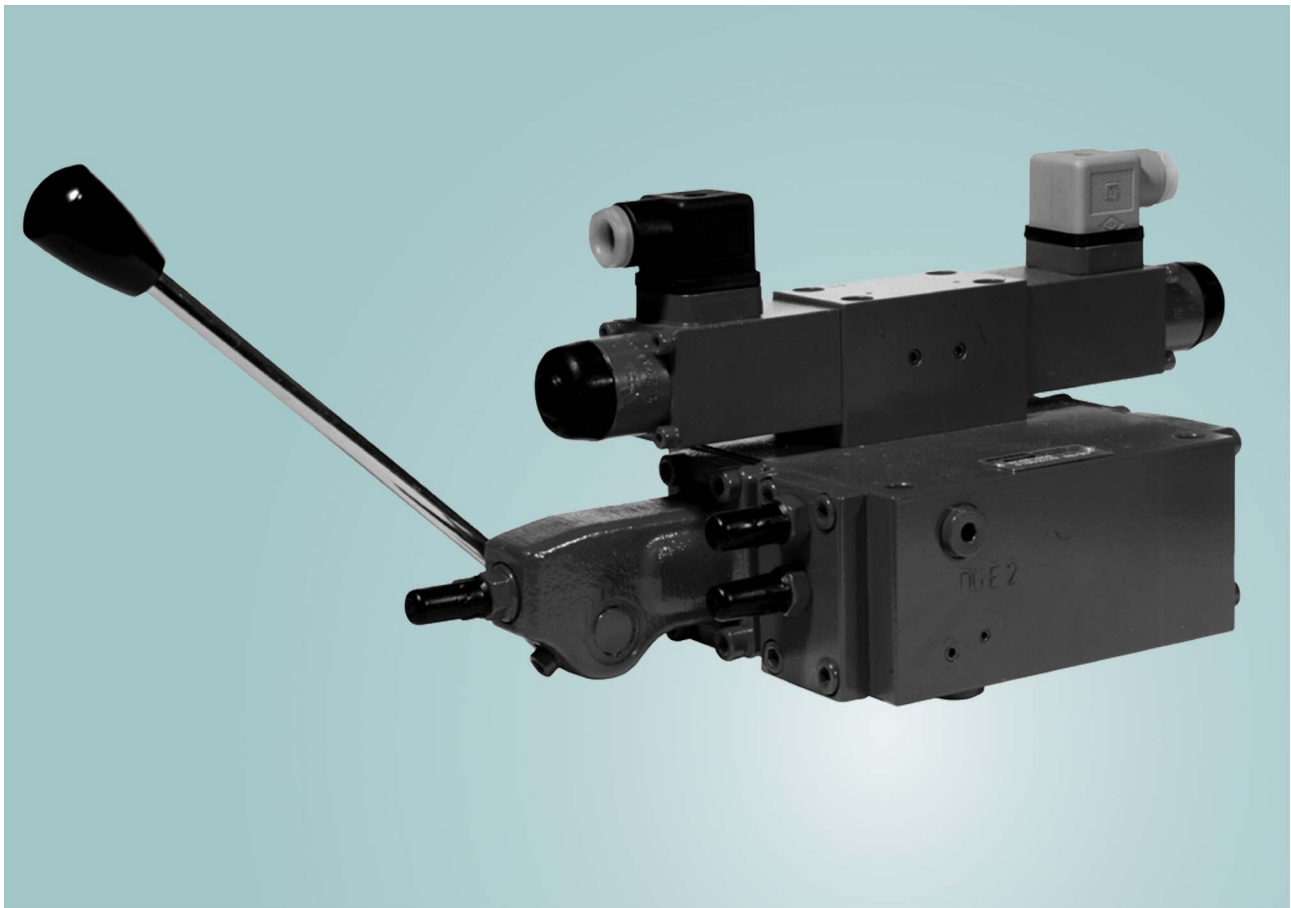

motion and progress

Contents

Page

1.	Functional description	3
1.1	The load check-back signal	3
1.2	The flow characteristics	4
2.	Description of the valve types with example of circuit	5
2.1	Circuits with fixed displacement pump	5
2.2	Circuits with adjustable control pump	7
3.	Actuating methods	8
3.1	Manual actuation	8
3.2	Hydraulic actuation YO	9
3.3	Electrical actuation E1/E2/M2(M1), proportional	9
3.4	Combined actuation	10
4.	Special functions/additional functionsen	10
4.1	Sandwich plate in the pilot circuit	10
4.2	Actuator pressure protection separated on A and B sidest	10
5.	Safety instructions	11
6.	Assembly instructions	11
6.1	Figure: Views of a proportional valve	11
7.	Adjustment instructions	12
8.	Sizes	12
8.2	Actuating methods	13
9.	Type codes	15
9.1	Type codes with example for ordering (MU valve with 2 actuator sections)	15
9.2	Position of the hand lever	16
9.3	Spool symbols	17
10.	Dimensions	17
10.1	Valves with actuating methods H6 / H7	18
10.2	Valves with actuating methods S1, S2, S3, S4 (Fig. 12 MD..S1O..)	18
10.3	Valves with actuating methodst Y0 (Fig. 12 MD..Y00..)	19
10.4	Valves with actuating methodst E1/E2 / E7/E8	19
10.5	Valves with actuating methodst M2(M1) / M3(M4)	20
10.6	Valves with actuating methodst M6(M5) / B6(B5)	21
10.7	Valves with actuating methodst Y1/Y2 / Y7/Y8	22
10.8	Valves with actuating methodst B2(B1) / B3(B4)	23
10.9	Valves with actuating methodst K1/K2 / K8(K5)	24
10.10	Valves with actuating methodst K9(K6) / K0(K7)	25
10.11	Valves with actuating methodst H0 (Fig. 12 MD..H0O..)	26

1. Functional description

MU/MR/MD series

Bucher's monoblock-type proportional valves control the volumetric flow to the actuator independent of the load. Monoblock means: all valves functions are integrated into one compact block. The valves comprise one pump connecting section and up to four proportional directional control valve sections.

Using valve-internal load check-back signaling to the pressure compensator, the actuated directional control valve operates independent of the load and controls the flow to ports A and B proportional to the actuation signal. All the

directional control valves can be actuated at the same time, but only the volumetric flow of the actuator with the highest pressure can be controlled independent of the load.*

A large number of valve variants allows optimum adaptation to the respective application. The actuating methods available – manual, hydraulic, electrical or any combination – and the variants with different pump connecting sections (with 2- or 3-way pressure compensator or pressure relief valve) open up a wide range of applications.

Hydraulic and electrical actuation can be performed by means of remote-control units and electronic amplifier cards that are perfectly adapted to the proportional valves.



***Remark:** Simultaneous, load-independent operation of several actuators enables us to offer a series of sandwich-type valves (see classification number 430.10.52). Each valve section in the sandwich-type valves is equipped with its own pressure compensator.

1.1 The load check-back signal

The load check-back signal is sent from the directional control valve section being actuated to the pump connecting section in the same way for all types of valve. In the diagram below (fig. 1.1.1), the main control spool of proportional directional control valve 2 is in its neutral position while main control spool 1 is actuated and consequently connects pump port P to actuating port A and actuating port B to tank port T. Immediately before metering edges P/A and B/T are opened, port A is connected to the spring cavity of the pressure compensator via load signaling channels in the spools and hou-

sing. Valves with several control spools are equipped with check valves in the load signaling channels. The load pressure signal can be tapped at port XL (in the area of the pump connecting section). In the neutral position of all proportional directional control valves, the load signaling channels are separated from the actuators. The pressure compensator is then depressurized by means of the DUE2 relief jets.

Valves of type MU integrate not only directional-control-valve and 3-way-flow-control functions but also the

functions of a primary pressure relief valve (only when the directional control valve is open) and bypass valve (when the directional control valve is closed). This valve is therefore particularly suitable for use with a fixed displacement pump.

Valves of type MD enable not only directional-control-valve and 2-way-flow-control functions but also the pressure reduction function (only when the directional control valve is open and when the preset pressure setting is exceeded).

1.1.1 Figure

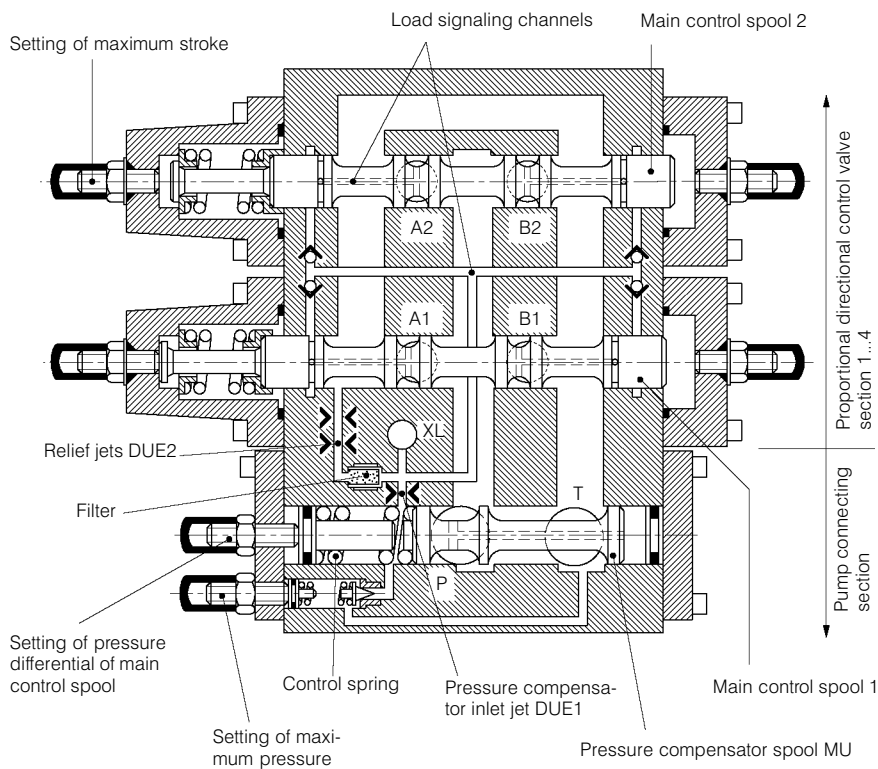

1.2 The flow characteristics

The directional control valves can be equipped with spools with different flow paths (see section 9.3, Spool symbols). The control cross-sections between the pump ports and actuator ports can be adapted individually for the respective application (see fig. 1.2.2). This

makes it possible to operate asymmetrical actuators, such as differential cylinders, at the same maximum speed in both directions of travel making full use of the stroke of the spool. When the directional control valves are in their neu-

tral position, the 3-way pressure compensator adopts the circulation position from P to T. The circulation pressure differential that arises is approx. 2 to 8 bar higher than the directional-control-valve pressure differential.

1.2.1 Flow characteristics with maximum displacement of main control spool

	NG 8	NG 12	NG 18	NG 25
Q [%]	Q [l/min]	Q [l/min]	Q [l/min]	Q [l/min]
100	50	100	200	450

1.2.2 Figure: Pressure drop at the main spool metering edges as a function of the valve flow rate, see also table 1.2.1, p. 4

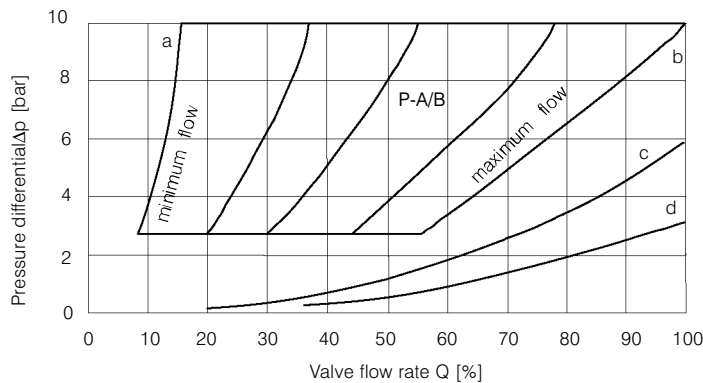

The chart shows the limits of application. The volumetric flow rates quoted are guidelines. They depend on a great number of parameters and must be determined on a case by case basis.

- | | | |
|--|--------------------------------------|-------------------------------------|
| a) Connection P-A/B with minimum cross-section | c) Connection A/B-T (spool model A) | d) Connection A/B-T (spool model C) |
| b) Connection P-A/B with maximum cross-section | Connection A-T (spool model D, F, L) | Connection A-T (spool model B) |
| | Connection B-T (spool model B, G, K) | Connection B-T (spool model D) |

2. Description of the valve types with example of circuit

2.1 Circuits with fixed displacement pump

2.1.1 Valve type MU: pump connecting section with 3-way pressure compensator

Circuit valve function

When the proportional directional control valve is in its neutral position, the load check-back signal from the two actuator ports A and B to the pressure compensator is interrupted. The combination of jets located in the load signaling channel lowers the pressure in the spring cavity to the pressure level in the tank. The delivery rate generated by the pump is fed back to tank port T via the pressure compensator with a slight pressure difference.

3-way flow control function

If the main control spool is displaced beyond the area of overlap, the load check-back signal is sent to the spring cavity of the pressure compensator. Due to the combined action with the pressure compensator, a constant pressure difference that is independent of the load pressure arises at the infinitely variable restrictor areas of the main control spool. In this way, a load-independent actuator flow arises, that is dependent only on the position of the control spool. The excess pump delivery rate returns to the tank.

Pressure relief valve function

If the pressure in the actuated actuator port rises above the value specified by the maximum pressure protection device due to the load, the maximum pressure valve opens and the pressure compensator spool assumes the function of the main stage of a pressure relief valve.

2.1.1.1 Figure

Example of a circuit with valve type MU:

Preferred application with fixed displacement pump for load-independent control of the volumetric flow for the actuator with the highest load pressure.

In addition, the pump connecting section takes care of maximum pressure protection of the entire system and serves as a recirculation valve with non-actuated actuators.

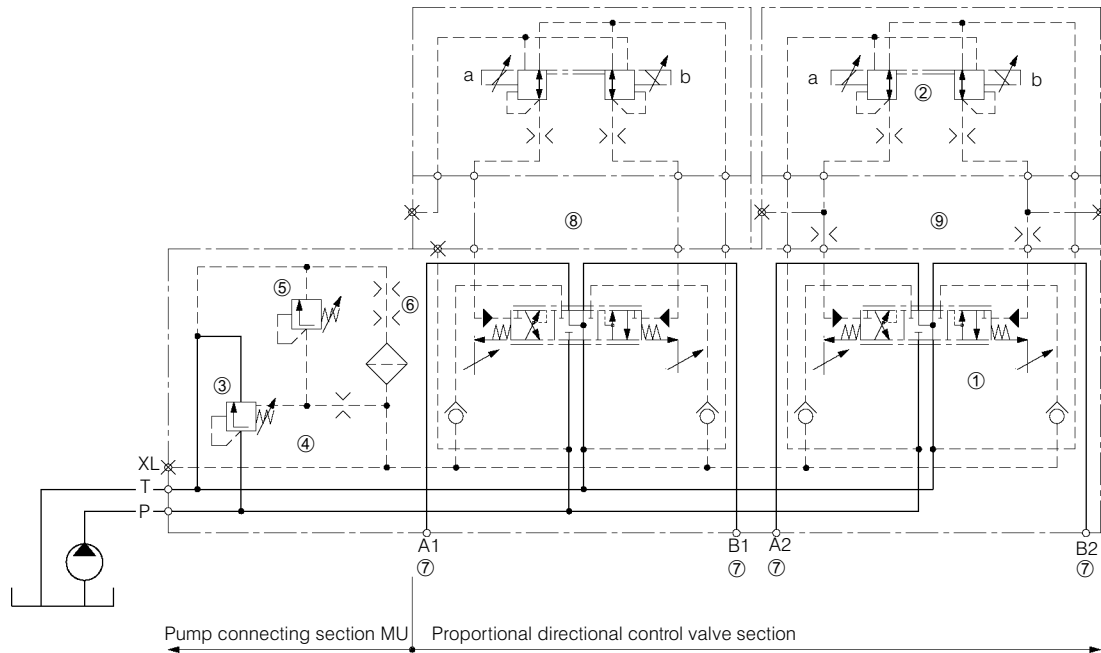

- ① Proportional directional control valve
- ② Pressure control valve (pilot valve)
- ③ 3-way pressure compensator
- ④ Damping jet in the load check-back signal
- ⑤ Pressure relief valve (pilot stage)
- ⑥ Relief jets for the load check-back signal system
- ⑦ Actuator connections
- ⑧ Sandwich plate in the pilot circuit, external control oil supply V10, see section 4.1, page 10
- ⑨ Sandwich plate in the pilot circuit, tapping of the pilot pressure signal V15, see section 4.1, page 10

- More performance on request

Example with electrical actuation

In the valve variant illustrated above, a pressure regulator is used as a pilot stage for actuating the main control spool.

For a functional description and characteristics, see section 3.3, page 9.

2.1.2 Valve type MR: pump connecting section with 3-way pressure compensator and heavy-duty tank port T1

Das The design of this valve is similar to that of the MU valve (see section 2.1.1, page 5). It has the same functions, but

has two return ports T and T1. Return port T1 for the excess pump delivery rate is separated from all other tank

connections which are combined in port T. This means that port T1 can withstand high loads (up to 350 bar).

2.1.2.1 Figure

Example of circuit with valve type MR

Application with a fixed or variable displacement pump for load-independent, proportional volumetric flow control of individual actuators.

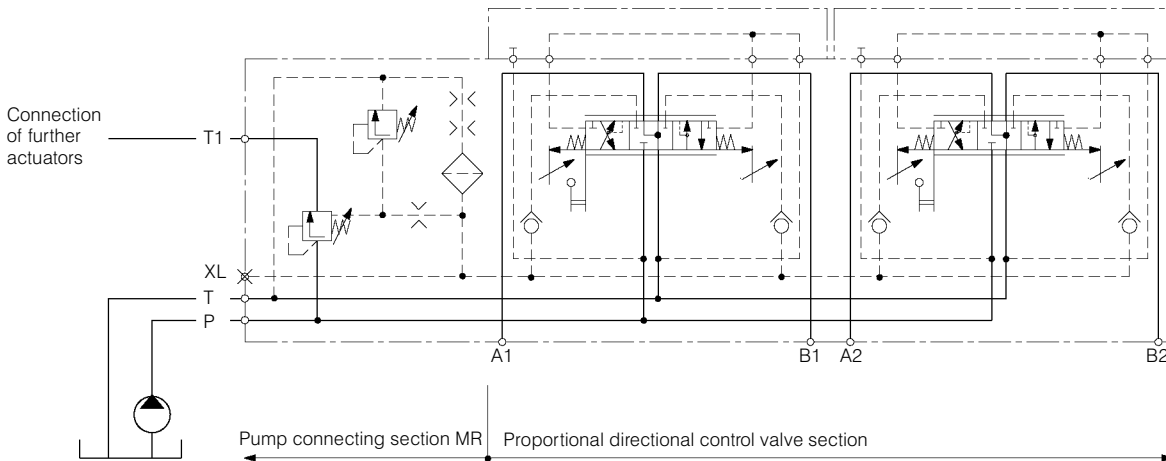

Displacement pump

Due to the capability of port T1 to withstand loads of up to 350 bar, the excess delivery rate of the fixed displacement pump can be used to supply further actuators (priority circuit).

Manual actuation of the main control spool

The main control spool is actuated mechanically. A number of different manually actuated versions are available. For a functional description and characteristics, see section 3.1, p. 8.

2.2 Circuits with adjustable control pump

2.2.1 Valve type ML: pump connecting section with pressure relief valve

The pump connecting section comprises a pilot-controlled pressure relief valve with pilot stage V and main stage H. The valve does not have recirculation-valve and flow-control functions. If pressure-regulated (a) or pressure- and delivery-rate-regulated (load-sensing principle) (b) variable displacement pumps also have to be protec-

ted, a valve of type ML with primary pressure protection must be fitted. When pressure-regulated pumps are being used, relief jet E1 can be replaced by a plug (must be specified in order). For pumps with load-sensing control, the load signal can be tapped at port XL. The load at the pump control

valve when the main spool is in neutral position can be relieved at the pump end (E2) or the valve end (E1) (must be specified in order).

 **Remark:** To enable us to set up the valve, we require Δp p of the pump regulator.

2.2.1.1 Figure: Example of circuit with valve type ML

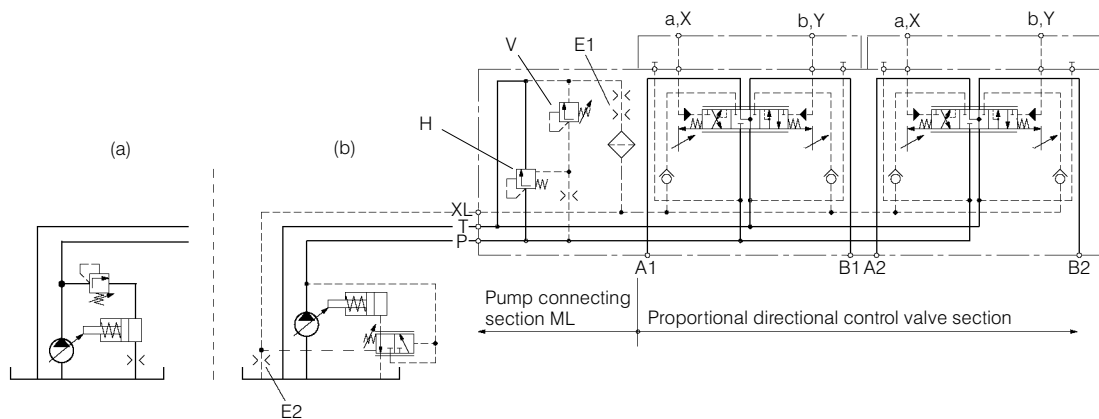

Example with hydraulic actuation (e.g. via control pressure sensor)

The control pressure differential required for adjusting the main control spool is generated by an external hydraulic control unit and fed via ports a,X and b,Y to the directional control valve. For a functional description and characteristics, see section 3.2, p. 9

2.2.2 Valve type MD: pump connecting section with 2-way pressure compensator

Seen in the direction of flow, from P to A or B, located upstream of the main control spool is a 2-way pressure compensator which, together with the metering orifice formed by the control spool, effects the load-independent flow control function. When several actuators are activated simultaneously, a load-

independent volumetric flow is only fed to the actuator with the highest working pressure. When the pressure in the actuated actuating port A or B rises due to loading above the value specified by the maximum pressure protection device, the pilot pressure relief valve (V) opens. As a result, the pressure com-

pensator closes the metering edge between the high-pressure (HD) and low-pressure (ND) channels. The volumetric flow from the pump to the actuator is reduced until it is completely interrupted; the pressure reduction function comes into effect.

2.2.2.1 Figure: Example of circuit with valve type MD

The figure illustrates electrical actuation. For a functional description and characteristics, see section 3.3, p. 9

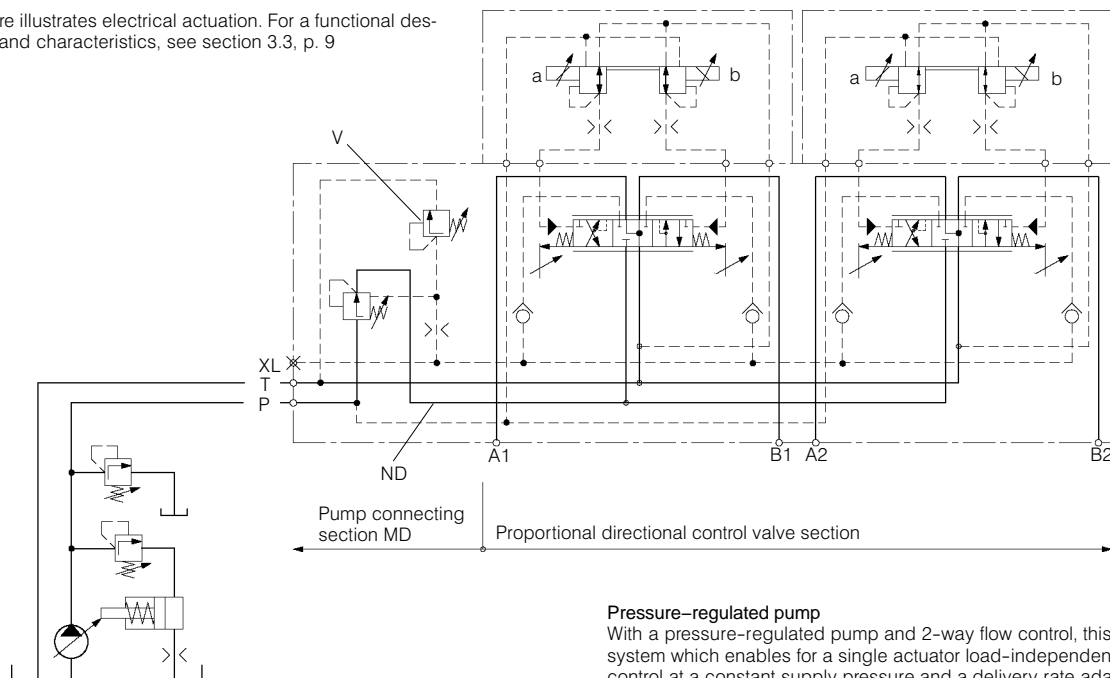

Pressure-regulated pump

With a pressure-regulated pump and 2-way flow control, this is a system which enables for a single actuator load-independent flow control at a constant supply pressure and a delivery rate adapted to the particular requirements. This type of circuit is disadvantageous from the point of view of energy when there is a great difference between the system and actuator pressures.

3. Actuating methods

All common methods of actuation can be used with our monoblock valves - manual, hydraulic, electrical and com-

binations of these. The designations H6, H7, S1 ... S4 etc. refer to the type code (see section 9., p. 15).

3.1 Manual actuation

3.1.1 Actuation H6

The manual actuation unit acts directly on the main spool. The housing of the manual actuation unit is pressure-tight up to 50 bar. The lever length required when the valve spool is in the neutral

position must be specified when ordering (see section 9.2, p. 16). The main control spool and the actuating element are held in the neutral position by a spring-loaded centering mecha-

nism. The actuating force increases as the displacement increases.

For technical data, see section 8.2.1, page 13.

3.1.2 Manual actuation with switching contact S1...S4

This actuating method is similar to H6 actuation, but is equipped with electrical switching contacts that serve to ac-

tivate and deactivate additional and auxiliary functions (valves, drives, relays etc.). Normally closed, normally

open and change over contacts can be implemented. See diagram in section 10.2, p. 18.

3.1.3 Manual actuation with positional locking and friction H7

With this actuating method, the main control spool is not spring-centered;

once the displacement has been set, it is maintained through self-locking.

3.2 Hydraulic actuation YO

In unactuated state, the main control spool is held in neutral position by a centering spring. When pressure is applied to control channels a, X/b and Y,

the main control spool is displaced proportional to the control pressure differential applied. For technical data, see section 8.2.2, p. 13.

Manually actuated, hydraulic pilot devices are used to generate the control pressure differential.

Technical information on request.

3.3 Electrical actuation E1/E2/M2(M1), proportional

An electrically and proportionally actuated pressure regulator serves as a pilot valve, the pressure as standard being supplied to it internally from the pump channel. The return line is connected internally to the tank channel. The main control spool is spring-centered and is displaced proportional to the electrical control current by the control

pressure differential regulated by the pilot valve. The supply and return of control oil requires the following minimum pressure differentials between the pump and tank ports or between the external ports: 8 bar for opening and 20 bar for full displacement of the main control spool. The electrical control cur-

rent is converted to a control pressure differential by proportional solenoids that continue displacing the pilot spool until an equilibrium of forces is achieved at the pilot spool between the magnetic force and the control pressure differential. For technical data, see section 8.2.3, p. 13.

3.3.1 Figure: Transient function

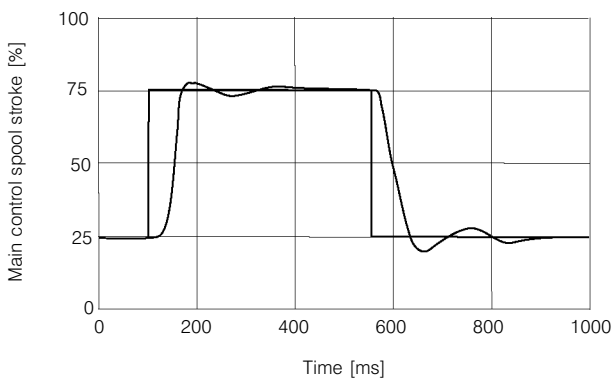

Transient function with step-shaped electrical input signal 50 % ± 25 %.

3.4 Combined actuation

3.4.1 hydraulic/manual H0

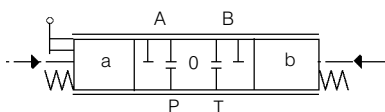

Priority is given to manual actuation when the actuating forces require this.

3.4.2 electrohydraulic/manual K...

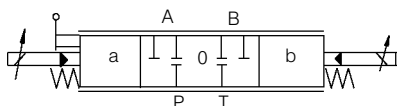

Priority is given to manual actuation when the actuating forces require this.

3.4.3 electrohydraulic/hydraulic Y../B..

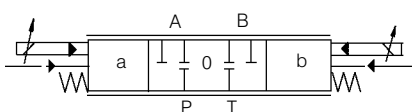

With this combination, the actuating method that is active is always that with the greatest control pressure differential.

4. Special functions/additional functions

In addition to the standard valve versions described in sections 1 to 3, there are numerous additional functions available for customizing systems to

the particular requirements for the control tasks to be solved. Section 4 provides an overview of the most important

of these additional functions. More detailed information is available on request.

4.1 Sandwich plate in the pilot circuit

(Assembly beneath the pilot valve)

Sandwich plates in the pilot circuit (assembly beneath the pilot valve), e.g. for external control oil supply V10 (see figure

2.1.1.1) or for tapping the pilot pressure signal V15 (see figure

2.1.1.1). Special options possible on request.

4.2 Actuator pressure protection separated on A and B sides

A further option is that of different pressure protection for the actuator ports A and B. It must be noted that the pressure at port B can only be set to a value lower than that at port A (see figure 4.2.1, p. 11). With this additional function, separate pilot pressure relief val-

ves are fitted for ports A and B. If the load pressure exceeds the values set at the pilot valves and the main control spool is open, the pressure compensator spool acts as a pressure relief valve in MU and MR valves and as a pressure reducing valve in MD and ML valves.



Anmerkung: With multiple valves, it is also possible to implement pressure protection on both sides (on request). This does not apply to actuating methods H6 and H7 and their combinations K10, K20 etc.

4.2.1 Figure: Example of circuit for separate actuator pressure protection in an MD valve

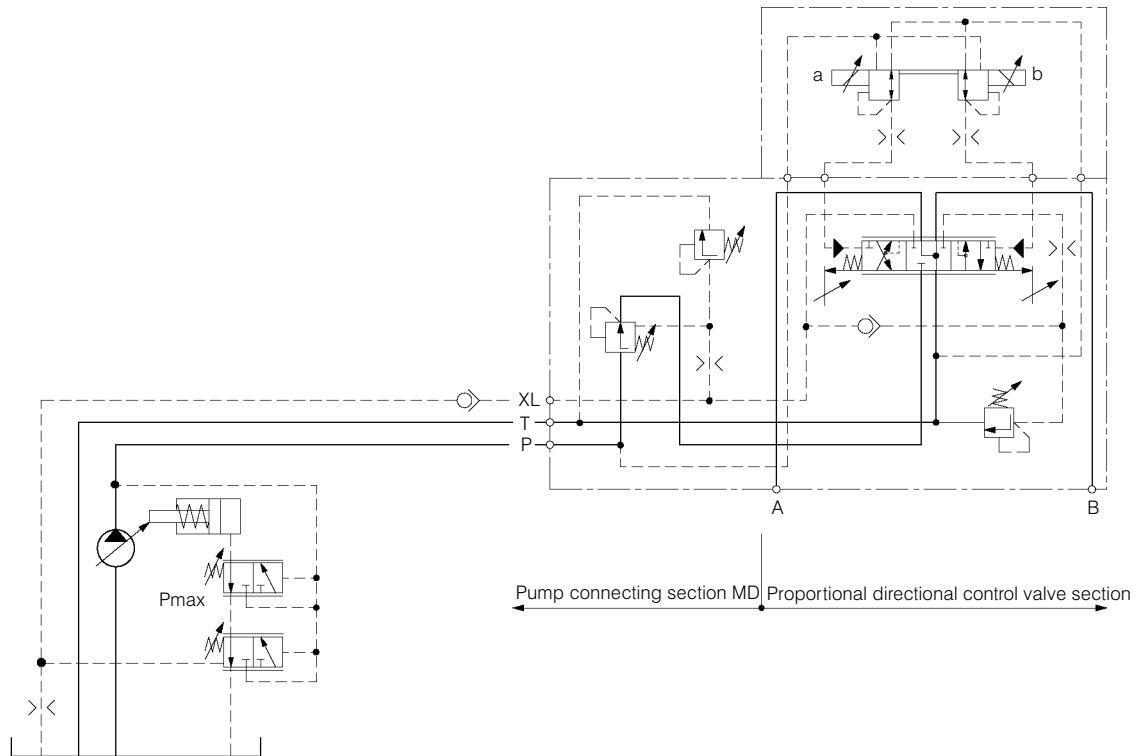

5. Safety instructions

Look for this User's Information about Proportional Valves in Monoblock- and Compac-type with the reference-no. 301-P-9050027.

6. Assembly instructions

6.1 Figure: Views of a proportional valve

Look for this User's Information about Proportional Valves in Monoblock- and Compac-type with the reference-no. 301-P-9050027.

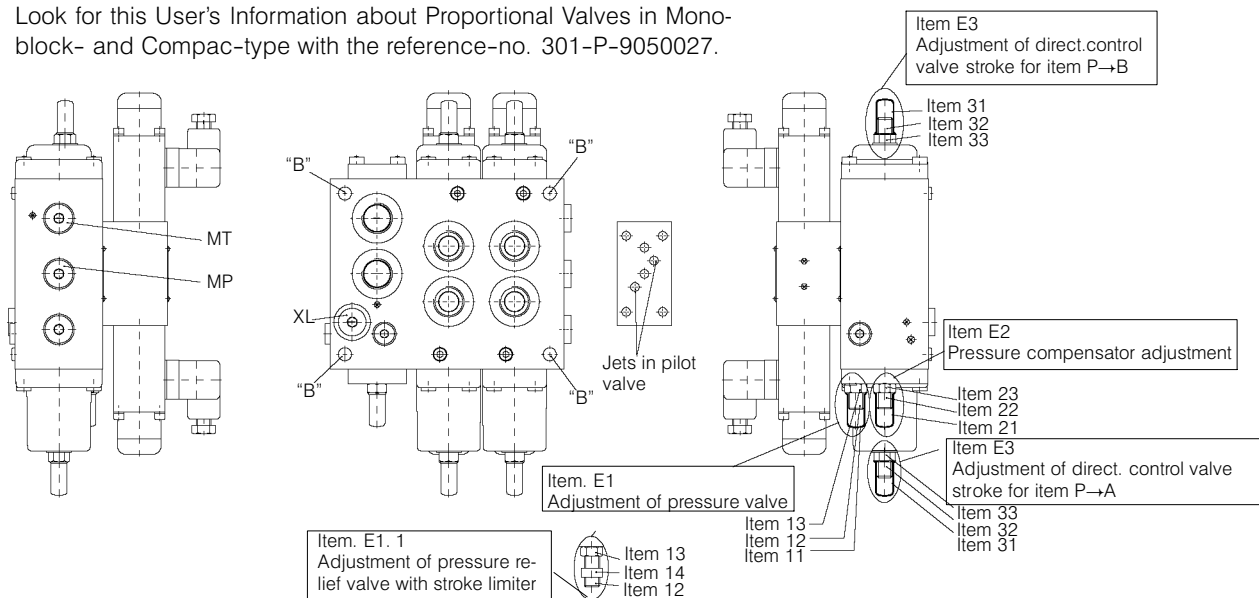

7. Adjustment instructions

Look for this User's Information about Proportional Valves in Monoblock- and Compac-type with the reference-no. 301-P-9050027.

8. Sizes

8.1 General

Design	all functions: spool valve pilot relief valve: seat valve
Actuation	electrically actuated proportional, hydraulic, manual
Type of connection	company standard: see sec. 10., p. 17 for connecting thread
Installation position	any (look for a good ventilation)
Weight	see table 8.1.1, p. 13
Ambient temperature	-30 ... 60°C
Hydraulic medium	mineral oil per DIN 51524 and DIN 51525 (HL/HLP)
Recommended pressure fluid temperature	20 ... 60°C
min. temperature	-20°C
max. temperature	80°C, other temperature on request
Recommended viscosity range	15 ... 100 mm ² /s
min. viscosity	10 mm ² /s
max. viscosity	380 mm ² /s
Filtering/purity class	see table 8.1.2, p. 13
Max. working pressure	
Port P/A/B	... 350 bar
Port T	... 50 bar
MR version only: Port T1	... 350 bar
Max. pump delivery rate	NG 8: 100l/min. NG 12: 200l/min. NG 18: 400l/min. NG 25: 900l/min.
Nominal flow	NG 8: 50l/min. NG 12: 100l/min. NG 18: 200l/min. NG 25: 450l/min.
Flow characteristics	see figure 1.2.2, p. 5

8.1.1 Table: Weight of valves MU, MR, MD, ML (single/twin/triple/quad) in kg

Actuation Valvesection	NG 8				NG 12				NG 18				NG 25			
	1	2	3	4	1	2	3	4	1	2	3	4	1	2	3	4
H6	4.0	5.3	6.6	7.9	7.3	9.4	11.5	13.6	15.8	20.6	26.4	31.2	-	-	-	-
H7	4.1	5.4	6.7	8.0	7.5	9.6	11.7	13.8	16.9	21.7	27.5	32.3	-	-	-	-
Y0	4.3	6.1	7.9	9.7	7.6	12.1	16.6	21.1	16.0	22.5	29.0	35.5	36.0	55.0	73.0	92.0
E1,E2, M2(M1), M3(M4)	5.8	10.0	14.2	18.4	9.1	14.5	19.9	25.3	17.6	25.7	33.8	41.9	38.0	59.0	80.0	101.0
K0 ... K9	6.4	10.9	15.4	19.9	9.9	15.6	21.3	27.0	19.5	28.5	37.5	46.5	-	-	-	-
H0	4.3	6.1	7.9	9.7	7.6	12.1	16.6	21.1	17.1	24.7	32.3	39.9	-	-	-	-
Y1,Y2, B2(B1), B2(B4)	7.8	14.0	20.2	26.4	11.1	18.5	26.0	33.5	19.6	28.3	37.0	45.7	40.0	64.0	88.0	112.0

8.1.2 Table: Functional safety and service life requirement

ISO 4406	class 18/15
NAS 1638	class 9

8.2 Actuating methods

8.2.1 Manual	Max. actuating angle	approx. 20 degrees
	Actuating force	
	neutral pos.	NG 8: 0.9 daN NG 12: 1.4 daN NG 18: 2.2 daN
	max. control	NG 8: 2.0 daN NG 12: 4.2 daN NG 18: 6.6 daN
8.2.2 Hydraulic	Control pressure range	6...18 bar
8.2.3 Electrohydraulic		
8.2.3.1 Proportional with 12 V and 24 VDC standard solenoids	Hysteresis of end value	≤6 % of rated current (control with 70 -100 Hz PWM signal)
	Recovery time for control spool stroke 25 %-75 %	Control characteristics (Figure 3.3.1, p. 9)
	Recommended dither freq.	70...100 Hz
	Supply pressure (internal and external) for the pilot valve	20...350 bar (*)
	Type of protection per DIN 40050	IP65
	Cyclic duration factor	100 %
	Insulation class	F
	Max. ambient temperature	45°C

(*) during the internal supply the circuit pressure has to be at least 8 bar in the resting position of the main spool valve

8.2.3.2 Tabelle

Voltage type	DC voltage	
Rated voltage	12 V	24 V
Coil resistance 5 % at 20°C	4.9 Ω	29.6 Ω
Coil resistance 5 % at 60°C	5.67 Ω	22.7 Ω
Control current range for Q = 0...100 %	480 ... 1200 mA	260 ... 650 mA
Power input at max. valve displacement (coil resistance at 60°C)	8.2 W	9.6W
Max. perm. current	1.9 A	0.95 A
Inductance (start of stroke...end of stroke)	0.07...0.13 H	0.29...0.55 H
Electrical connection	Power socket per DIN EN 175301-803 (DIN 43650)	

8.2.3.3 Switching (ON/OFF) in explosion-proof version (intrinsically safe)

Type of protection per EG RL 94/9	 I M2 EEx ia I
Rated voltage	12 V
Making current	260 mA
Holding current	130 mA
Power input	
Switch-on	3.2 W
Holding	1.6 W
Solenoid certification	DMT 99 ATEX E 102

8.2.3.4 Proportional as explosion-proof version (intrinsically safe)

Type of protection per EG RL 94/4	 I M2 EEx ia I
Rated voltage	12 V
Control current range for Q = 0...100 %	90...270 mA
Power input at max. valve displacement	< 2 W
Solenoid certification	DMT 99 ATEX E 102

9. Type codes

9.1 Type codes with example for ordering (MU valve with 2 actuator sections)

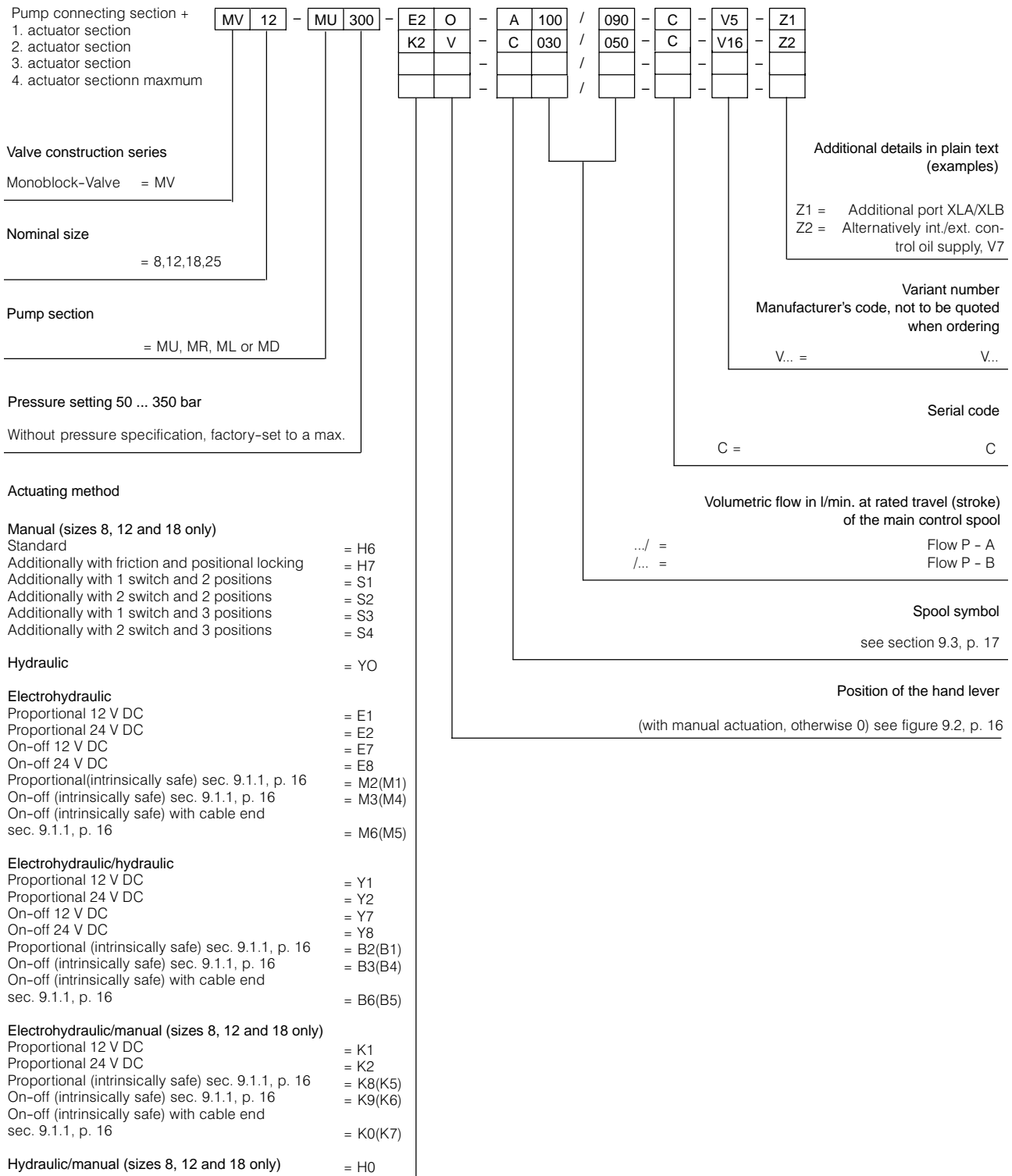

9.1.1 Type code table

	Old-unit 30.06.03	New-from 01.07.03
Designation	EE ia I	I M2 EE i a I
Approval No.	BVS Nr. 85.1035	DMT 99 ATEX E 102
Electric proportional	M1	M2
ON/OFF	M4	M3
	M5*	M6*
Electro-hydraulic prop.	B1	B2
ON/OFF	B4	B3
	B5*	B6*
Electro-mech. prop.	K5	K8
ON/OFF	K6	K9
	K7*	K0*

* on request only

9.2 Position of the hand lever

Manual actuating methods H0/H6/H7/K/S
Possible lever positions

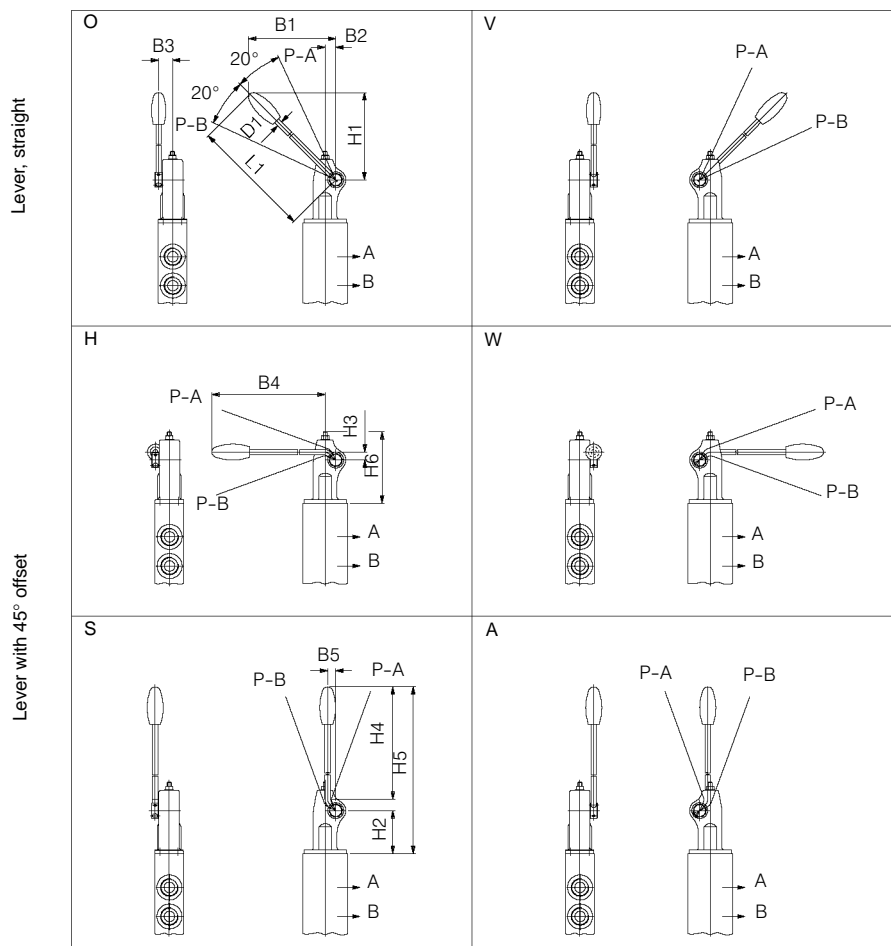

Dimensions

NG	B1	B2	B3	B4	B5	H1	H2	H3	H4	H5	H6	L1	D1
8	145.5	10.5	18.5	194	11.2	148	43.3	11.2	177	238	78	198	8
12	146	14	19.5	194	11.2	148	50.3	11.2	177	245	95	198	8
18	230.5	19.5	28	316	15	232	81.30	15	294	398	135	320	10

9.3 Spool symbols

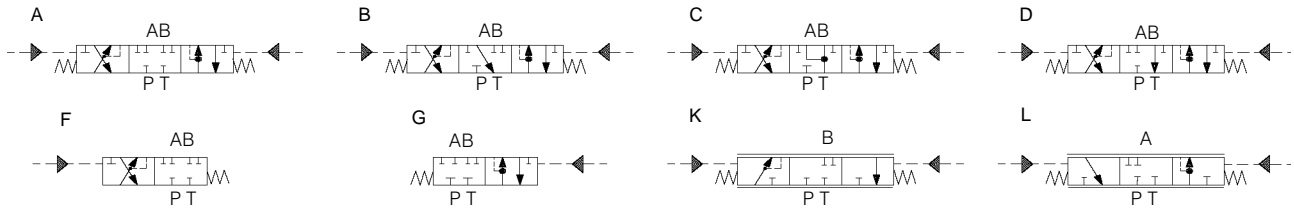

10. Dimensions

Valve types

(Fig. 12M... Y00...)

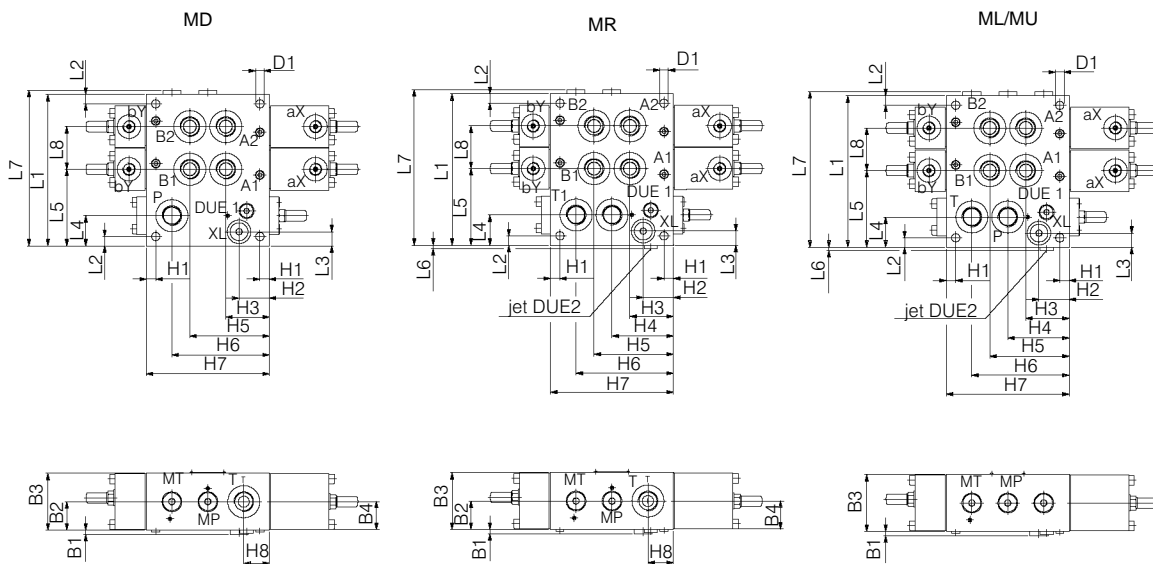

Dimensions

NG	L2	L3	L4	L5	L6
8	5.5	14	29	71	-
12	10	15	32	81	3.5
18	9	40	36.5	103.5	-
25	18	55	55	145	-

Monobloc with 1 actuator section

NG	L1	L7	L8
8	100	103.5	-
12	115	119.5	-
18	140	144.5	-
25	200	204.5	-

Monobloc with 2 actuator sections

NG	L1	L7	L8
8	140	143.5	40
12	160	164.5	45
18	200	204.5	60
25	-	-	-

Monobloc with 3 actuator sections

NG	L1	L7	L8
8	180	183.5	40
12	205	209.5	45
18	260	264.5	60
25	-	-	-

Monobloc with 4 actuator sections

NG	L1	L7	L8
8	220	223.5	40
12	250	254.5	45
18	320	324.5	60
25	-	-	-

Dimensions

NG	H1	H2	H3	H4	H5	H6	H7	B1	B2	B3	B4
8	7.5	24	36	50	64	78	100	4.5	25	50	27.5
12	10	32	46	65	84	103	130	4.5	30	60	30
18	10	27.5	63	90	117	144	180	4.5	40	80	40
25	10	47	83	120	157	194	240	4.5	55	110	55

Fastening hole

Connecting thread

NG	D1	P/T/T1*	A/B*	XL*	MP/MT
8	6.4	G 3/8	G 3/8	G 1/4	G 18
12	9	G 1/2	G 1/2	G 1/4	G 1/4
18	11	G 1	G 1	G 1/4	G 1/2
25	M12, 19 deep	G 1 1/2	G 1 1/2	G 1/4	G 3/4

* DIN 3852

10.1 Valves with actuating methods H6 / H7

10.1.1 Valve with actuating method H6 (Fig. 12 MD..H6O..)

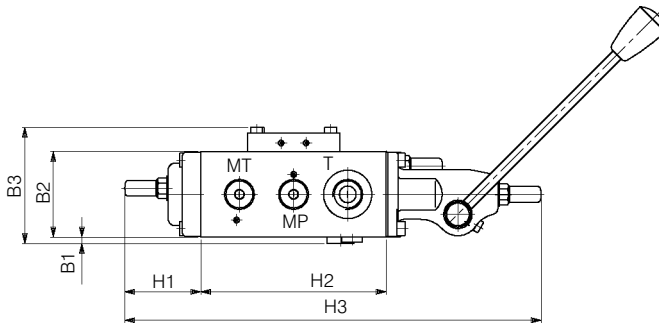

Dimensions

NG	B1	B2	B3	H1	H2	H3
8	4.5	50	71.5	42.5	100	233.7
12	4.5	60	81.5	53.5	130	292.3
18	4.5	80	101.5	58.5	180	388.3

10.1.2 Valve with actuating method H7 (Fig. 12 MD..H7O..)

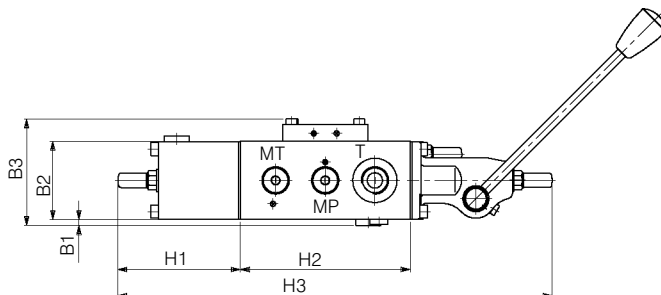

Dimensions

NG	B1	B2	B3	H1	H2	H3
8	4.5	50	71.5	76.8	100	268
12	4.5	60	81.5	93.8	130	332.6
18	4.5	80	101.5	107.8	180	437.6

10.2 Valves with actuating methods S1, S2, S3, S4 (Fig. 12 MD..S1O..)

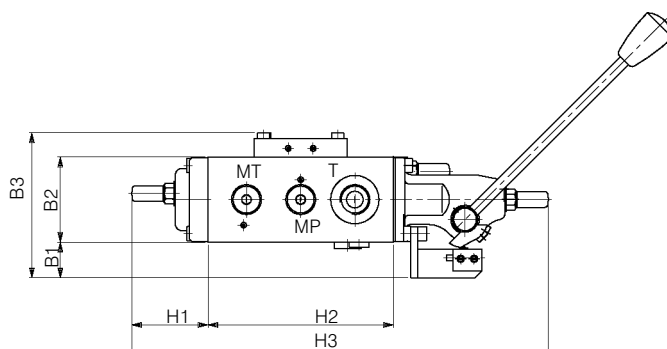

Dimensions

NG	B1	B2	B3	H1	H2	H3
8	26	50	93	42.5	100	233.7
12	25	60	102	53.5	130	292.3
18	25.5	80	122.5	58.5	180	388.3

10.3 Valves with actuating methodst YO (Fig. 12 MD..Y00..)

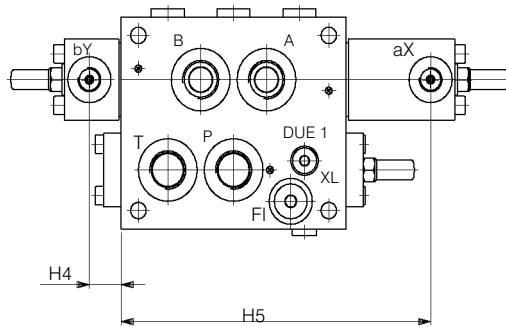

Dimensions

NG	B1	B2	B3	B4
8	4.5	50	56	-
12	4.5	60	66	-
18	4.5	80	86	-
25	4.5	110	-	149

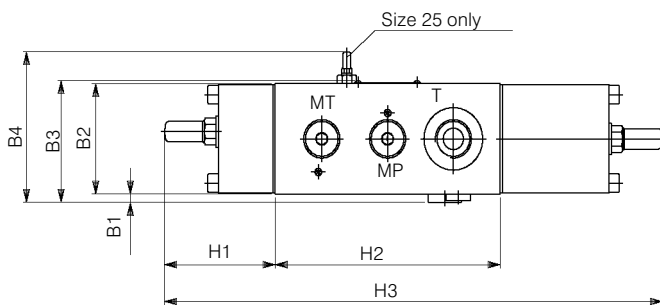

Connecting thread

NG	H1	H2	H3	H4	H5	aX/bX
8	51.8	100	228.6	14.3	136.3	G1/4"
12	63.8	130	287.6	18.3	178.8	G1/4"
18	59.8	180	347.6	13.3	237.3	G1/4"
25	77.5	240	470	15	328	G1/4"

10.4 Valves with actuating methodst E1/E2 / E7/E8

10.4.1 Valve with actuating method E1/E2 (Fig. 12 MD..E10/E20..)

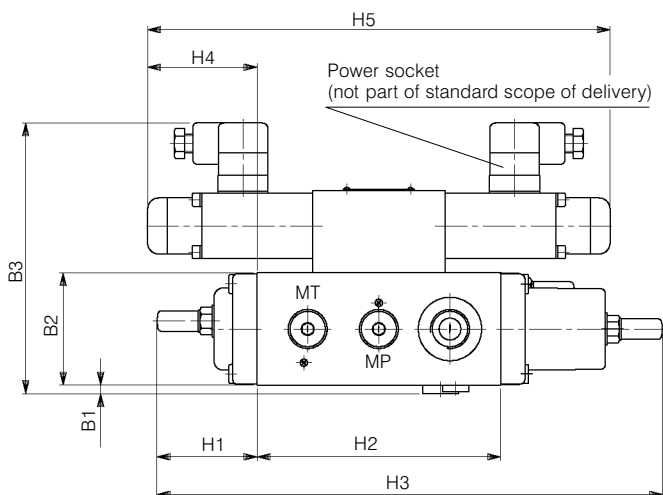

Dimensions

NG	B1	B2	B3
8	4.5	50	135
12	4.5	60	145
18	4.5	80	165
25	4.5	110	195

NG	H1	H2	H3	H4	H5
8	42.5	100	210	67	app. 234
12	53.5	130	270	52	app. 234
18	58.5	180	345	27	app. 234
25	77.5	240	470	-3	app. 234

10.4.2 Valve with actuating method E7/E8 (Fig. 12 MD..E70/E80..)

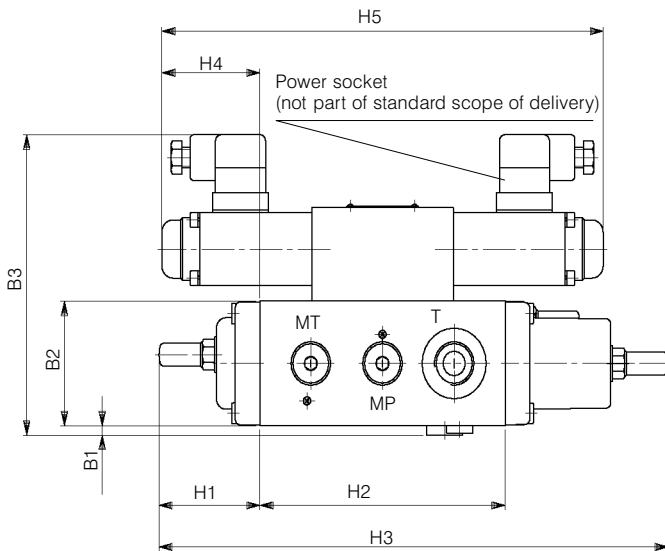

Dimensions

NG	B1	B2	B3
8	4.5	50	135
12	4.5	60	145
18	4.5	80	165
25	4.5	110	195

NG	H1	H2	H3	H4	H5
8	42.5	100	210	67	234
12	53.5	130	270	52	234
18	58.5	180	345	27	234
25	77.5	240	470	-3	234

10.5 Valves with actuating methodst M2(M1) / M3(M4)

10.5.1 Valve with actuating method M2(M1) (Fig. 12 MD..M20(M10)..)

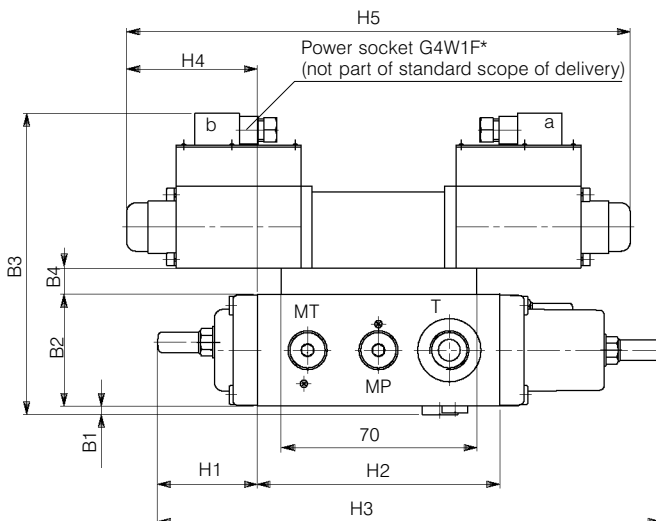

* contact occupation 1 and 2

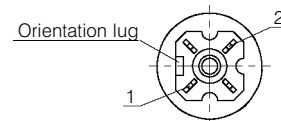

Dimensions

NG	B1	B2	B3	B4	H1	H2	H3	H4	H5
8	4.5	50	151	10	42.5	100	210	85	270
12	4.5	60	161	10	53.5	130	270	70	270
18	4.5	80	181	10	58.5	180	345	45	270
25	4.5	110	201	-	77.5	240	470	15	270

10.5.2 Valve with actuating method M3(M4) (Fig. 12 MD..M30(M40)..)

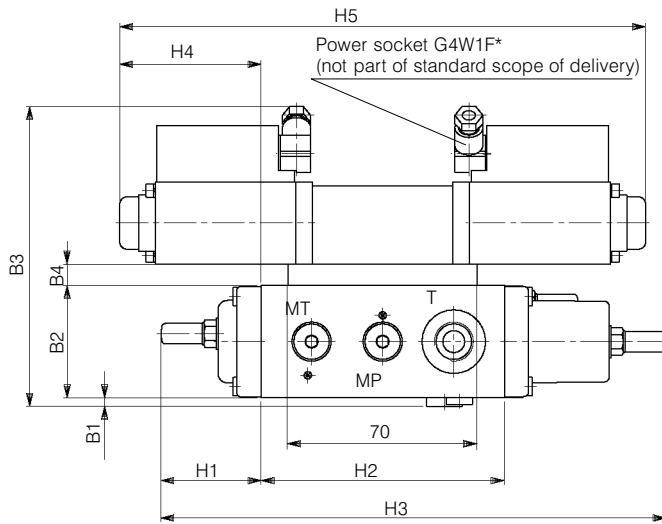

* contact occupation 1 and 2, see page 20.

Dimensions

NG	B1	B2	B3	B4
8	4.5	50	153	10
12	4.5	60	163	10
18	4.5	80	183	10
25	4.5	110	203	-

NG	H1	H2	H3	H4	H5
8	42.5	100	210	90.5	281
12	53.5	130	270	75.5	281
18	58.5	180	345	50.5	281
25	77.5	240	470	20.5	281

10.6 Valves with actuating methodst M6(M5) / B6(B5)

10.6.1 Valve with actuating method M6(M5) on request only (Fig. 12 MD.. M60(M50)..)

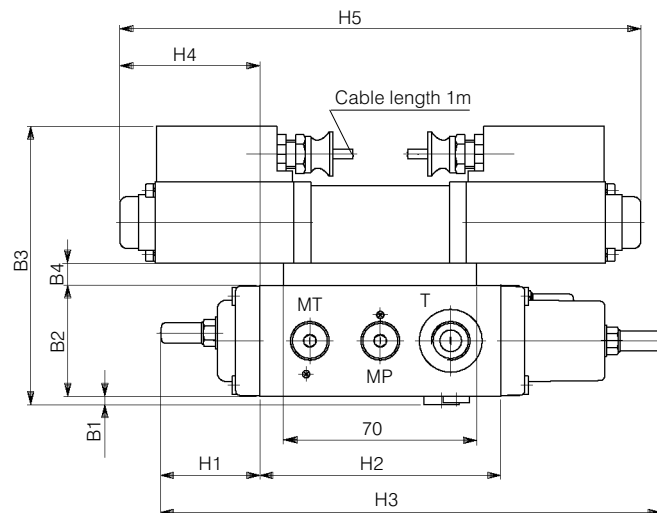

Dimensions

NG	B1	B2	B3	B4
8	4.5	50	142	10
12	4.5	60	152	10
18	4.5	80	172	10
25	4.5	110	192	-

NG	H1	H2	H3	H4	H5
8	42.5	100	210	90.5	281
12	53.5	130	270	75.5	281
18	58.5	180	345	50.5	281
25	77.5	240	470	20.5	281

10.6.2 Valve with actuating method B6(B5) on request only (Fig. 12 MD..B60(B50)..)

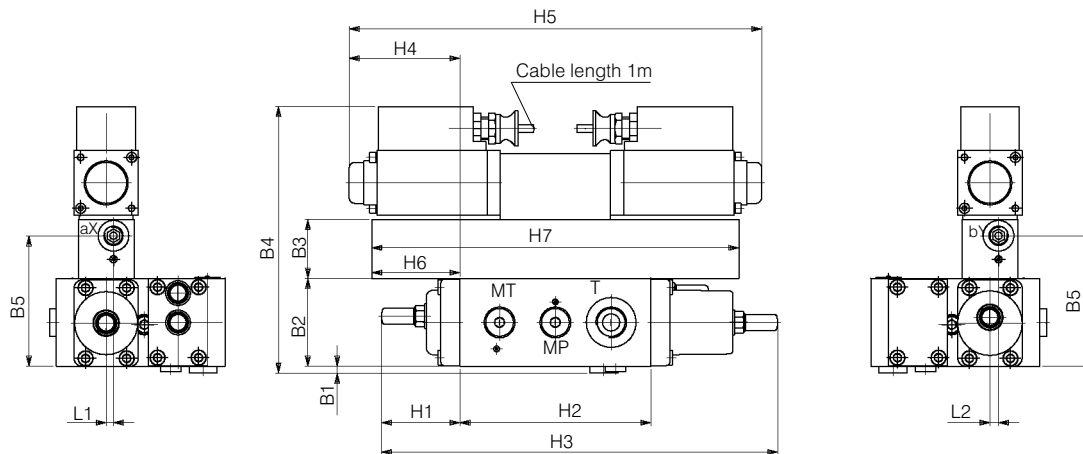

Dimensions

Connecting thread

NG	B1	B2	B3	B4	B5	L1	L2	aX/bX	H1	H2	H3	H4	H5	H6	H7
8	4.5	50	40	172	79	5	5.9	G1/4"	42.5	100	210	90.5	281	75	250
12	4.5	60	40	182	89	5	5.9	G1/4"	53.5	130	270	75.5	281	60	250
18	4.5	80	40	202	109	5	5.9	G1/4"	58.5	180	345	50.5	281	35	250
25	4.5	110	40	232	139	5	5.9	G1/4"	77.5	240	470	20.5	281	5	250

10.7 Valves with actuating methodst Y1/Y2 / Y7/Y8

10.7.1 Valve with actuating method Y1/Y2 (Fig. 12 MD..Y10/Y20..)

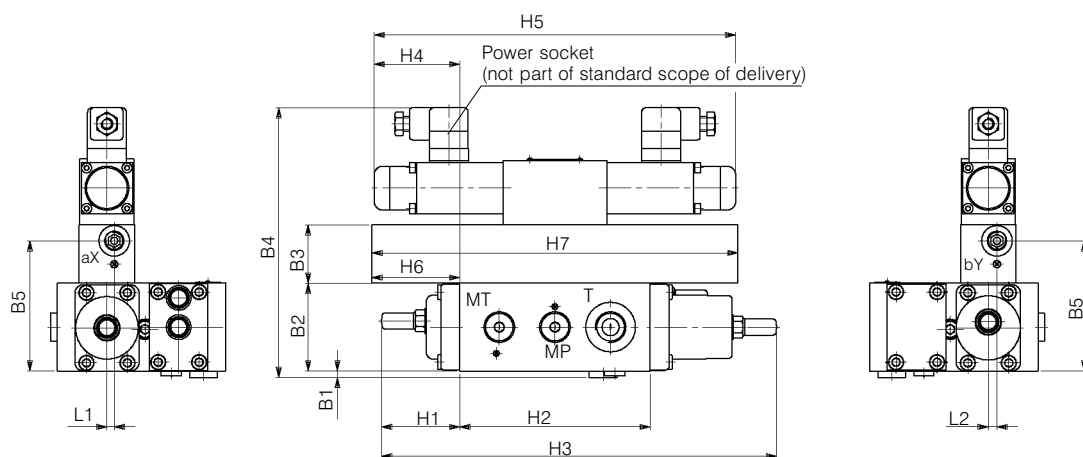

Dimensions

Connecting thread

NG	B1	B2	B3	B4	B5	L1	L2	aX/bX	H1	H2	H3	H4	H5	H6	H7
8	4.5	50	40	175	79	5	5.9	G1/4"	42.5	100	210	67	app. 234	75	250
12	4.5	60	40	185	89	5	5.9	G1/4"	53.5	130	270	52	app. 234	60	250
18	4.5	80	40	205	109	5	5.9	G1/4"	58.5	180	345	27	app. 234	35	250
25	4.5	110	40	235	139	5	5.9	G1/4"	77.5	240	470	-3	app. 234	5	250

10.7.2 Valve with actuating method Y7/Y8 (Fig. 12 MD..Y70/Y80..)

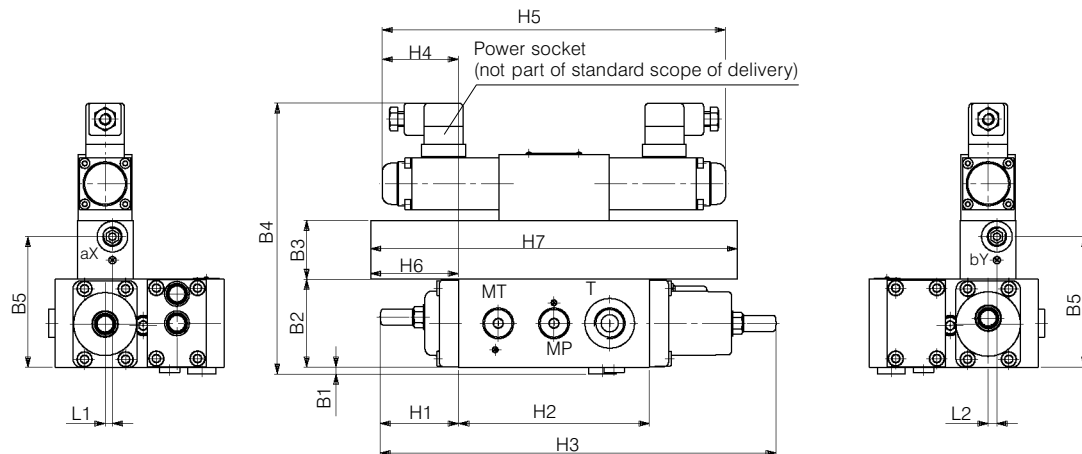

Dimensions

Connecting thread

NG	B1	B2	B3	B4	B5	L1	L2	aX/bX	H1	H2	H3	H4	H5	H6	H7
8	4.5	50	40	175	79	5	5.9	G1/4"	42.5	100	210	67	234	75	250
12	4.5	60	40	185	89	5	5.9	G1/4"	53.5	130	270	52	234	60	250
18	4.5	80	40	205	109	5	5.9	G1/4"	58.5	180	345	27	234	35	250
25	4.5	110	40	235	139	5	5.9	G1/4"	77.5	240	470	-3	234	5	250

10.8 Valves with actuating methodst B2(B1) / B3(B4)

10.8.1 Valve with actuating method B2(B1) (Fig. 12 MD..B20(B10)..)

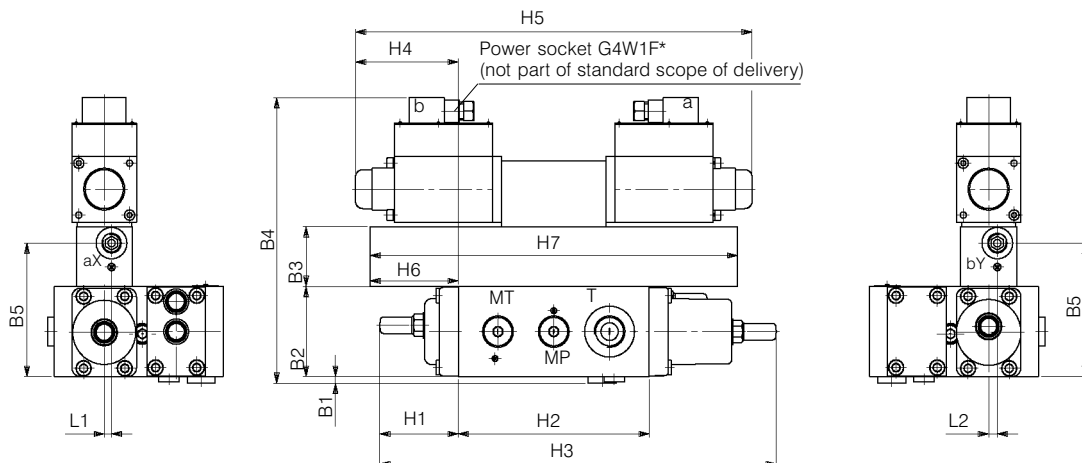

* contact occupation 1 and 2, see page 20.

Dimensions

Connecting thread

NG	B1	B2	B3	B4	B5	L1	L2	aX/bX	H1	H2	H3	H4	H5	H6	H7
8	4.5	50	40	181	79	5	5.9	G1/4"	42.5	100	210	85	270	75	250
12	4.5	60	40	191	89	5	5.9	G1/4"	53.5	130	270	70	270	60	250
18	4.5	80	40	211	109	5	5.9	G1/4"	58.5	180	345	45	270	35	250
25	4.5	110	40	241	139	5	5.9	G1/4"	77.5	240	470	15	270	5	250

10.8.2 Valve with actuating method B3(B4) (Fig. 12 MD..B30(B4)..)

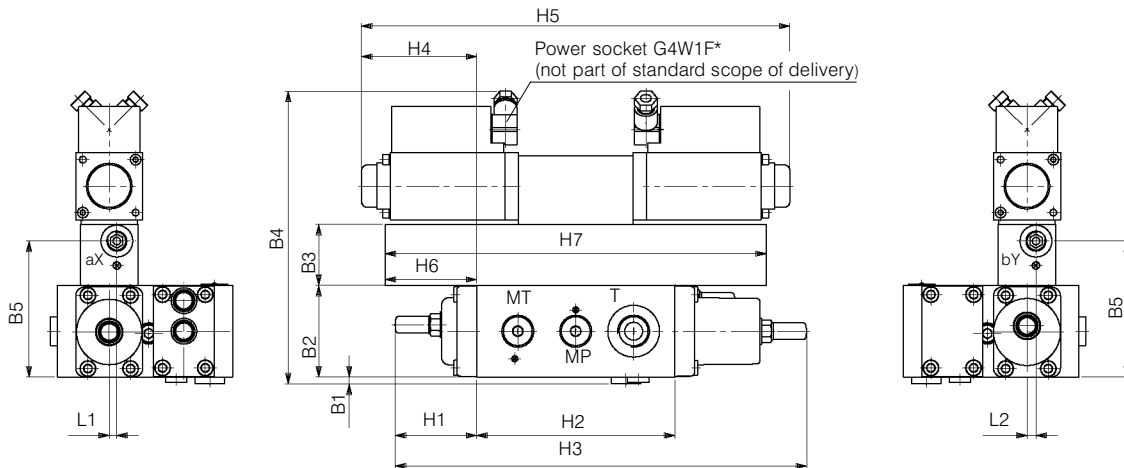

* contact occupation 1 and 2, see page 20.

Dimensions

Connecting thread

NG	B1	B2	B3	B4	B5	L1	L2	aX/bX	H1	H2	H3	H4	H5	H6	H7
8	4.5	50	40	183	79	5	5.9	G1/4"	42.5	100	210	90.5	281	75	250
12	4.5	60	40	193	89	5	5.9	G1/4"	53.5	130	270	75.5	281	60	250
18	4.5	80	40	213	109	5	5.9	G1/4"	58.5	180	345	50.5	281	35	250
25	4.5	110	40	243	139	5	5.9	G1/4"	77.5	240	470	20.5	281	5	250

10.9 Valves with actuating methodst K1/K2 / K8(K5)

10.9.1 Valve with actuating method K1/K2 (Fig. 12 MD..K10/K20..)

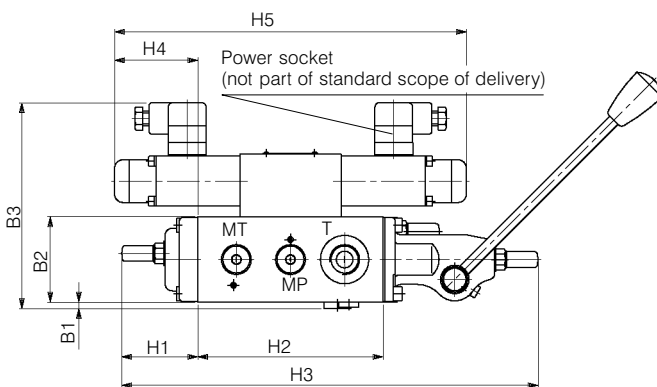

Dimensions

NG	B1	B2	B3
8	4.5	50	135
12	4.5	60	145
18	4.5	80	165

NG	H1	H2	H3	H4	H5
8	42.5	100	233.7	73.5	247
12	53.5	130	292.3	58.5	247
18	58.5	180	388.3	33.5	247

10.9.2 Valve with actuating method K8(K5) (Fig. 12 MD..K80(K5O)..)

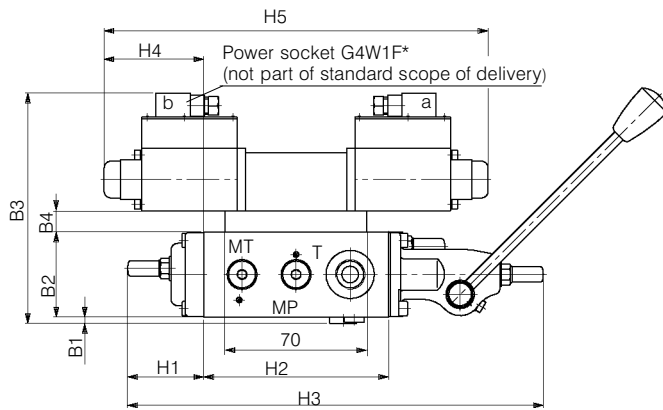

* contact occupation 1 and 2, see page 20.

Dimensions

NG	B1	B2	B3	B4
8	4.5	50	151	10
12	4.5	60	161	10
18	4.5	80	181	10

NG	H1	H2	H3	H4	H5
8	42.5	100	233.7	85	270
12	53.5	130	292.3	70	270
18	58.5	180	388.3	45	270

10.10 Valves with actuating methodst K9(K6) / K0(K7)

10.10.1 Valve with actuating method K9(K6) (Fig. 12 MD..K90(K6O)..)

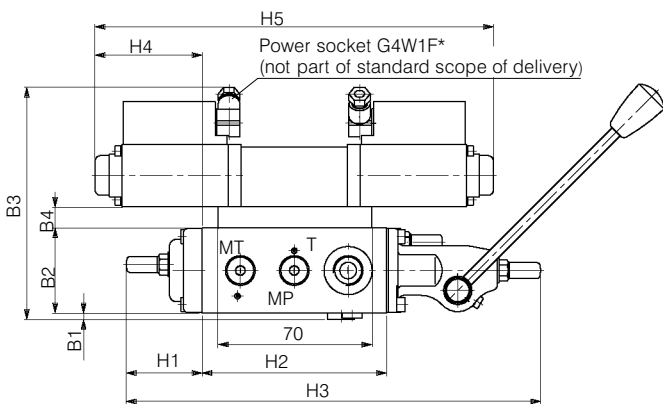

* contact occupation 1 and 2, see page 20.

Dimensions

NG	B1	B2	B3	B4
8	4.5	50	153	10
12	4.5	60	163	10
18	4.5	80	183	10

NG	H1	H2	H3	H4	H5
8	42.5	100	233.7	90.5	281
12	53.5	130	292.3	75.5	281
18	58.5	180	388.3	50.5	281

10.10.2 Valve with actuating method K0(K7) (Fig. 12 MD..K00(K7O)..)

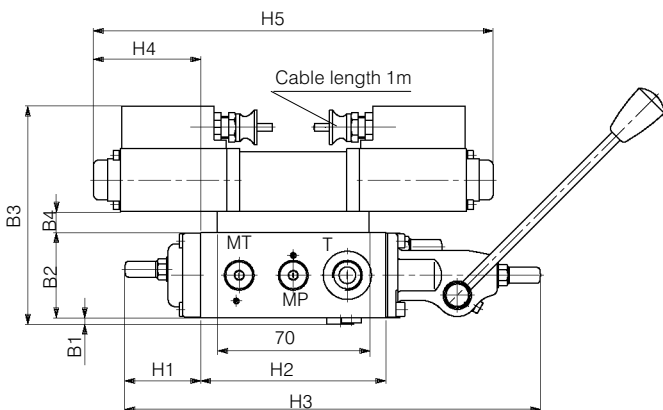

Dimensions

NG	B1	B2	B3	B4
8	4.5	50	142	10
12	4.5	60	152	10
18	4.5	80	172	10

NG	H1	H2	H3	H4	H5
8	42.5	100	233.7	90.5	281
12	53.5	130	292.3	75.5	281
18	58.5	180	388.3	50.5	281

10.11 Valves with actuating methodst H0 (Fig. 12 MD..H0O..)

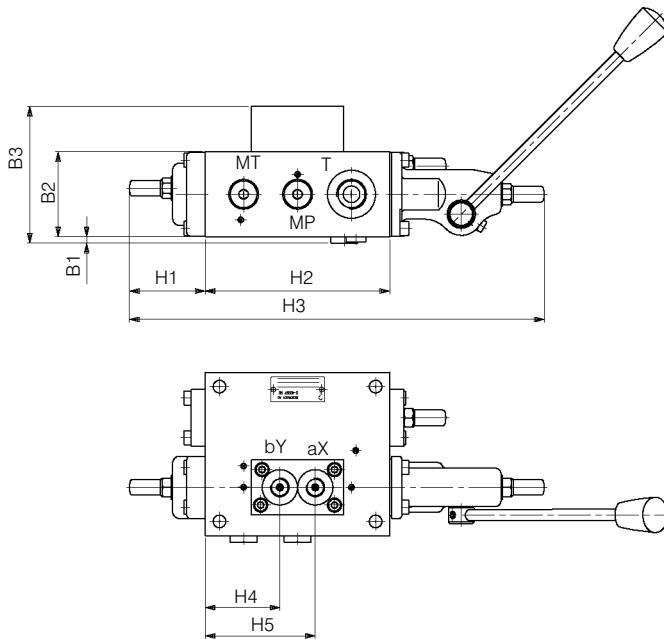

Dimensions

NG	B1	B2	B3	H1	H2	H3	H4	H5
8	4.5	50	86.5	42.5	100	233.7	37.5	62.5
12	4.5	60	96.5	53.5	130	292.3	52.5	77.5
18	4.5	80	116.5	58.5	180	388.3	77.5	102.5

Connecting thread

aX/bX
G1/4"
G1/4"
G1/4"

BUCHER HYDRAULICS

Germany

Phone +49 7742 85 20
 Fax +49 7742 71 16
 info.de@bucherhydraulics.com

France

Phone +33 389 64 22 44
 Fax +33 389 65 28 78
 info.fr@bucherhydraulics.com

Netherlands

Phone +31 79 34 26 24 4
 Fax +31 79 34 26 28 8
 info.nl@bucherhydraulics.com

UK

Phone +44 24 76 35 35 61
 Fax +44 24 76 35 35 72
 info.uk@bucherhydraulics.com

USA

Phone +1 262 605 82 80
 Fax +1 262 605 82 78
 info.wi@bucherhydraulics.com

Switzerland

Phone +41 33 67 26 11 1
 Fax +41 33 67 26 10 3
 info.ch@bucherhydraulics.com

Italy

Phone +39 0522 92 84 11
 Fax +39 0522 51 32 11
 info.it@bucherhydraulics.com

Austria

Phone +43 6216 44 97
 Fax +43 6216 44 97 4
 info.at@bucherhydraulics.com

China

Phone +86 10 64 44 32 38
 Fax +86 10 64 44 32 35
 info.bj@bucherhydraulics.com

Product Center (Elevator)

Phone +41 41 757 03 33
 Fax +41 41 757 16 49
 info.nh@bucherhydraulics.com

www.bucherhydraulics.com

We reserve the right of modification without notice.