

- **Very robust construction for mechanical engineering and industrial plant application**
- **For converting linear displacements of up to 30 m into a rotary movement**
- **For mounting onto an absolute or incremental encoder**
- **Easy to install and to use**
- **Protection grade IP 65 (IP 54)**

KEY INFORMATION OVERVIEW

DESIGN & FUNCTION

The linear movement of a flexible steel cable with a length of up to 30 m is converted into a rotary movement with the aid of a measuring drum. The measuring drum is connected to the shaft of an encoder. In this way a change in displacement of the measuring cable causes the shaft of the encoder to rotate by a directly proportional amount which can be recorded.

The restoring force of the spring drive holds the measuring cable tight at all times and prevents any sagging which would otherwise induce an error. The measuring drum moves axially on a spindle ensuring that the cable is wound up precisely and reproducibly wrap for wrap in the helical groove of the drum.

The nozzle, through which the cable enters the drum, is protected with a brush and a bellow to prevent water or dust entering the drum.

FEATURES AND INTERFACES OF ENCODERS

The cable converter is supplied with or without encoder. Generally encoders and converters are supplied as one unit.

Upon request both items are also available as separate units.

Suitable for mounting on the SWF draw-wire displacement transducer are T-series encoders with digital, incremental or analogue interfaces, C-series and K-series as well as the DAF model series with analog interface.

Preferably, encoders with TWK flange designs 58 or 50 are used. Encoders with other mounting flanges can be mounted on request.

TECHNICAL DATA
MECHANICAL DATA

Measuring ranges	5, 10, 15, 20, 25, 30 m
Drum circumference	334 mm nom. ¹⁾
Permissible cable speed v_{max}	ref. to table page 4
Permissible cable acceleration a_{max}	ref. to table page 4
Force required to draw out the cable (start / end)	15 N max. / 30 N max.
Cable material	stainless steel 1.4401, highly flexible steel wires (7x19 = 133 wires)
Cable diameter	1.3 mm (0.8 mm optional)
Life span for cable and spring drive	$\geq 10^6$ changes of load
Housing material	anodized aluminium
Spring housing material	plastic
Protection grades	housing IP65 cable entry IP54
Working and storage temperature range	-20 °C to +70 °C
Mass	ref. to table page 4

1) The actual value is shown on the item when supplied.

ORDER CODE FORMAT

SWF	5	B	-	27
------------	----------	----------	----------	-----------

SWF	Cable type displacement converter SWF		
5	Measuring range	5	5 m
		10	10 m
		15	15 m
		20	20 m
		25	25 m
		30	30 m
B	Accessories (options)	B	With bellows (standard)
		U	With deflection roller SWF-U
		BÜ	With external brush chamber SWF-BÜVO to avoid entry of dust
27	Electrical and/or mechanical variants*	01	For flange design 58
		04	For flange design 105
		06	For flange design 65
		07	For flange design 66
		27	For flange design 50

* The basic versions according to the data sheet bear the number 01. Deviations are identified with a variant number and are documented at TWK.

ACCESSORIES (TO BE ORDERED SEPARATELY)
ADAPTER

ADAKIT50 Adapter ring for encoder flange design 50
ADAKIT58 Adapter ring for encoder flange design 58
ADAKIT65 Adapter ring for encoder flange design 65
ADAKIT66 Adapter ring for encoder flange design 66

DEFLECTION ROLLER

360° deflection roller for cable

SWF-U refer to SWF10749

BRUSH CHAMBER

External set of brushes for applications in dusty environment

SWF-BÜVO refer to SWF11195

CABLE

Cable extension (X = extension in meters, e.g. 2,5 for two and a half meters)

SWF-V-X-01 refer to SWF11027

ATTACHMENT FOR COMPRESSED AIR

Recommended in applications with saw mills - for example

SWF-DRUVO refer to SWF11173

For use under aggressive ambient conditions, e.g. in maritime climate, the converters can be supplied with a protective anodised hard coating.

DOCUMENTATION
DOCUMENTATION

The following documents can be found in the Internet under www.twk.de/en in the documentation area, model SWF.

Data sheet [SWF10652](#)
 CE Declaration of Conformity [ZE12467](#)
 UKCA Declaration of Conformity [ZE16569](#)
 Reach compliant [QS15286](#)
 RoHS compliant [QS13284](#)

INSTALLATION DRAWINGS

MODEL SWF WITH BELLOW AND FOR FLANGE DESIGN 58

Dimensions in mm

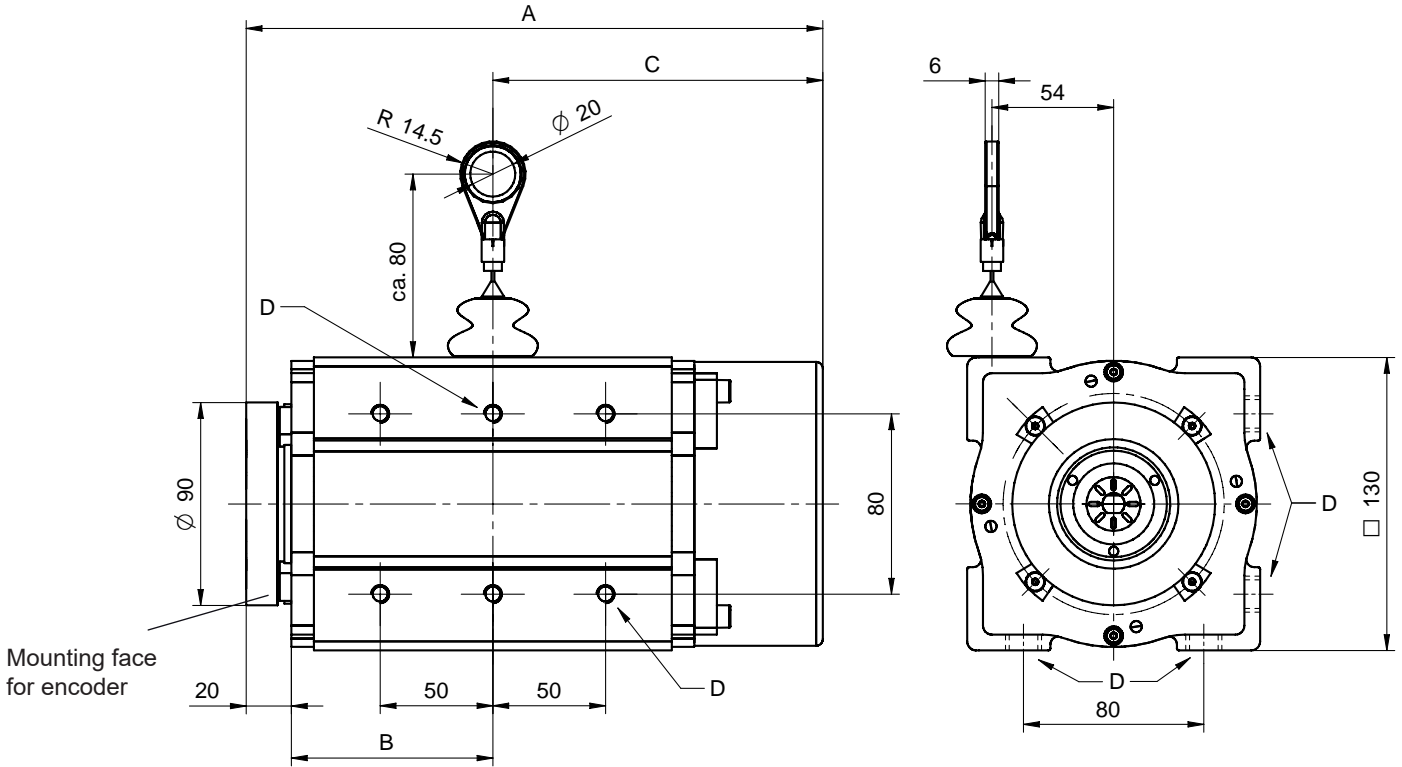

SIZES A TO D, MASS, CABLE SPEED AND CABLE ACCELERATION

Models	5 m	10 m	15 m	20 m	25 m	30 m
A	142	187	256	301	370	415
B	45	67	89	112	134	157
C	77	100	147	169	216	238
D	2 x M8, 8 deep			6 x M8, 8 deep		
Mass (kg)	3	4	5.5	6.5	7.5	8.5
v_{max} @ T = 20 °C	12 m/s	12 m/s	10 m/s	10 m/s	6 m/s	6 m/s
a_{max} @ T = 20 °C	70 m/s ²	60 m/s ²	40 m/s ²	30 m/s ²	25 m/s ²	15 m/s ²

MOUNTING POSITION

The threaded holes (D) at two faces permit to adjust the position of the cable exit to suit the requirements.

NOTE

The cable exit should be downwards or sideways. The cable must be extracted rectilinearly with reference to the housing (no lateral deflection admitted).

CONSTRUCTION

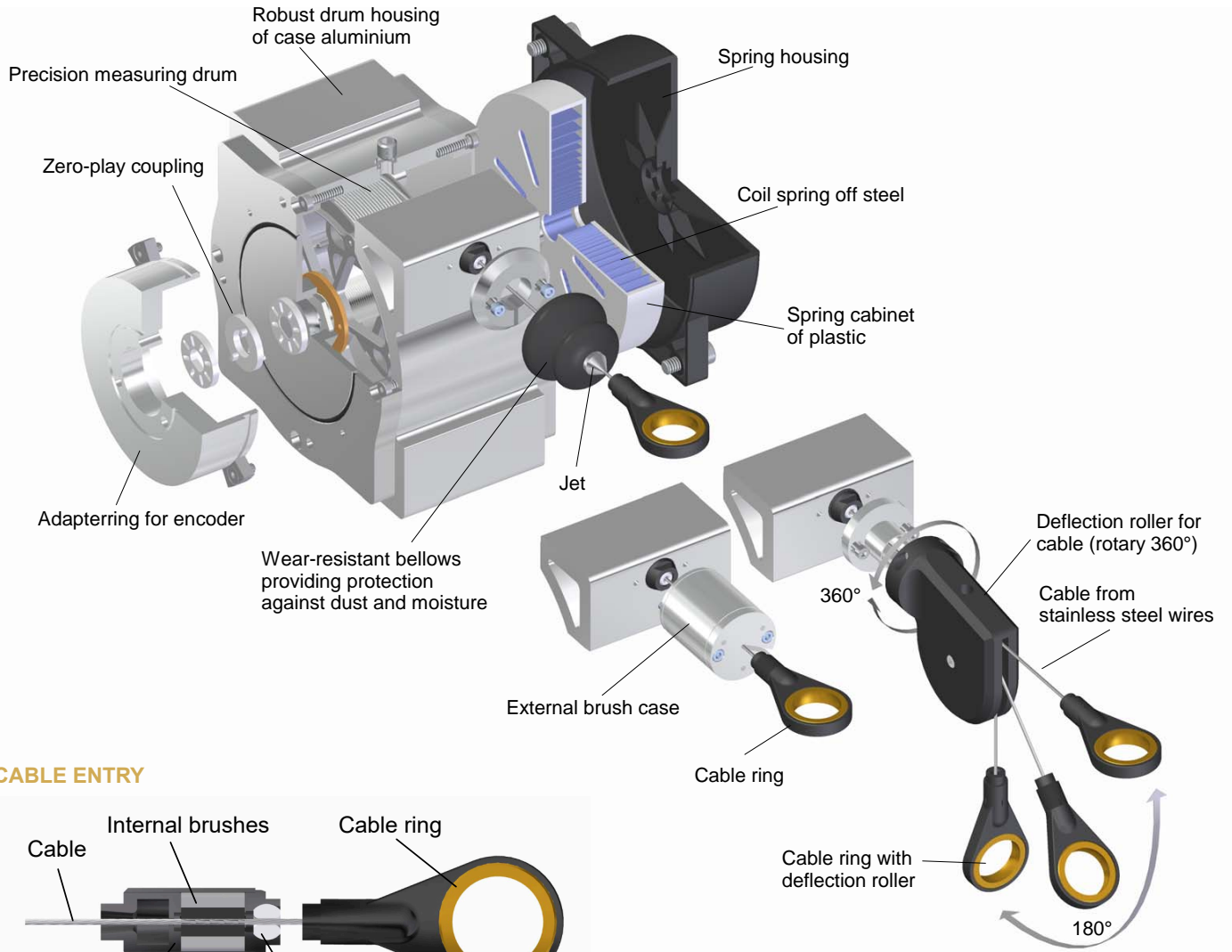

CABLE ENTRY

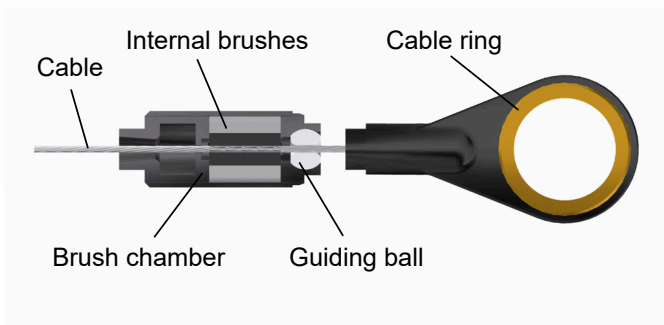

CABLE EXTENTION SWF-V-X-01

The cable extension SWF-V-X-01 is to be ordered separately. The "X" is the cable extension in meters. E.g. "SWF-V-7-01" extends the cable by 7 m (measured at the outside lying inner edges of the snap hook and the round eyelet).



Dimensions in mm

