

January 2018

Continuously Evolving TAWERS!

The Arc Welding Robot System

TAWERS



NEW



TS series



Separate Type



Through-Arm Type



External Type



TL series

TM series

TAWERS WGIII/WGHIII

Robot Systems with Integrated Welding Power Source Technology

Torch type selectable to fit your application!

WGIII/WGHIII

TM-1400WGIII

TM series



Separate Type

Superior wire feedability and reduced cable interference



Through-Arm Type

Focused on reducing cable interference



External Type

Focused on wire feedability

TM
1100
1400
1600
1800
2000

Space saving & high payload!

TS-950

NEW

TS series



External Type

Through-Arm Type

WGIII/WGHIII

TS
800
950

Payload
8 kg
TS-800/950

Long-arm & high payload!

WGIII/WGHIII

TL series



External Type

TL
1800
2000

Payload
TL-1800: **8 kg**
TL-2000: **6 kg**

Manipulator Lineup (as of January 2018)

	TS series		TM series					TL series	
	800	950	1100	1400	1600	1800	2000	1800	2000
Separate	—	—	○	○	○	○	○	—	—
Through-Arm	○	○	○	○	○	○	○	—	—
External	○	○	○	○	—	—	—	○	○
Payload	8 kg		6 kg		4 kg	6 kg		8 kg	6 kg

Rated Welding Output:

WGIII: 350 A @ 80 % duty cycle (CV). 350 A @ 60 % duty cycle (pulse).

WGHIII: 450 A @ 100 % duty cycle (CV/pulse)

A variety of features specialized for arc welding

Feature 1 (TM/TL) Enhanced Basic Performance

Increased Motion Speed

TM-1400: Speed of main 3 axes increased by 22 % on average. (approx. 42"/s more than TA type)

Extended Reach

TM-1400: 1 437 mm (63 mm more than TA type)

Feature 2 (TS/TM) Arm Specialized for Welding

Cantilever Structure makes arm compact and improves accessibility to workpieces.



Feature 3 (TM/TL) Structure Specialized for Welding Clean Cable Management!

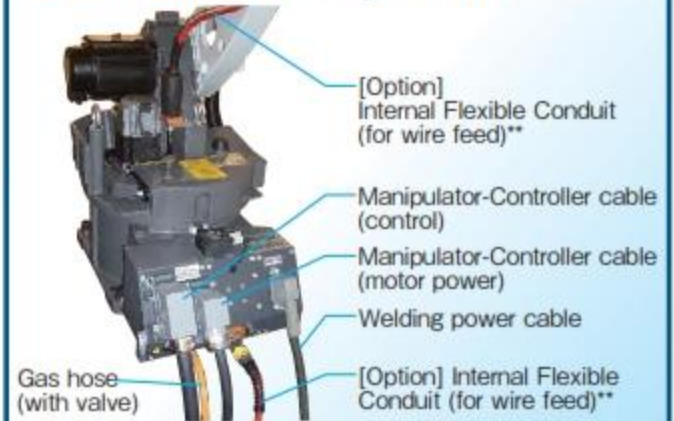

**For use with drum packing wire only.

In addition to Through-Arm Type and External Type,

A third choice—Separate Type (TM series)

Revolutionary new type of arc welding robot with advantages of both Through-Arm Type and External Type.



Feature 1 External Flexible Conduit

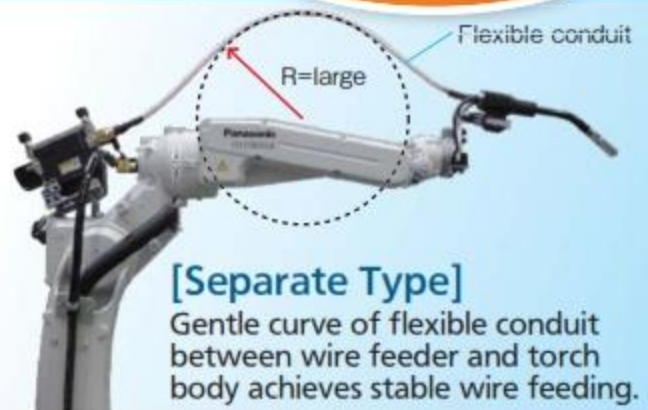
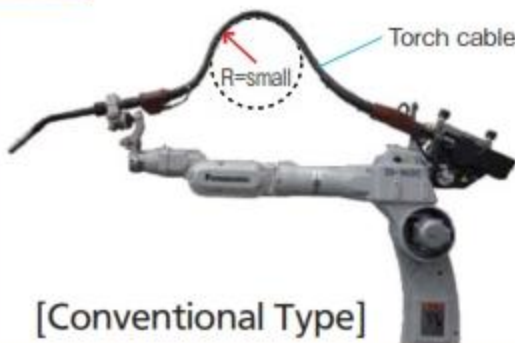

Feature 2 Through-Arm Power Cable

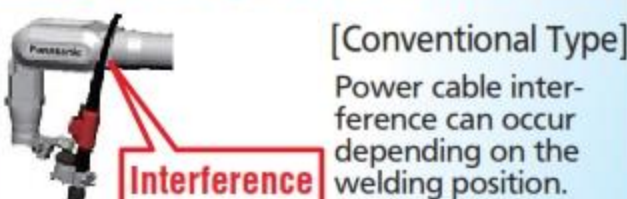

[Separate Type]

Through-arm power cable reduces cable interference.



An example of circumferential welding

Suppresses twist of wire!



Reduces target position error at weld start and end points!

New type welding robot achieves even higher quality welds.

"Weld Navigation" allows easy parameter setting Standard



Easy setting with Teach Pendant



Note: Screens are subject to change without notice.

Rich welding parameter database developed through our long experience

"Weld Navigation" reduces parameter setting time.

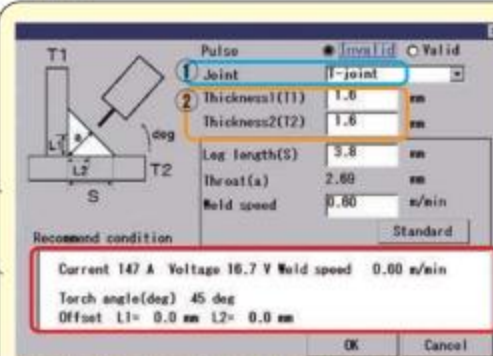

Note: Torch angle and aiming point also calculated

Two Easy Steps:

1. Select weld joint. The figure changes according to the joint.



2. Select plate thicknesses. That's all!

The right parameters automatically

Leg length and weld speed are also adjustable.

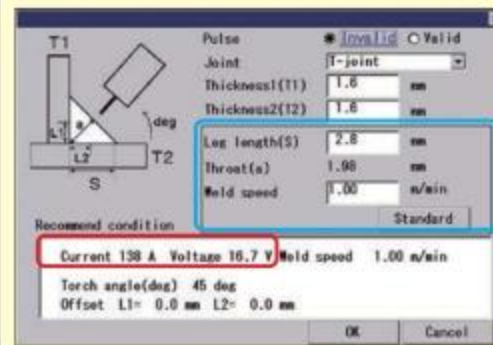

Weld Navigation recalculates weld current and voltage according to the changes.

Notes: *Parameters by Weld Navigation are guideline only and do not guarantee welding result.
*Consult us for material and processes available with Weld Navigation.

WGIII controller with high performance

- Compared to the conventional model, 6 times faster main CPU and 4 times more memory capacity reduce start-up time by 50 % to **about 30 seconds.**



WGIII

WGHIII

Improved maintainability

- Swivel rack in the case makes maintenance easy and saves space.
- Cables with connectors on both ends reduce Cable exchange time.



Swivel rack

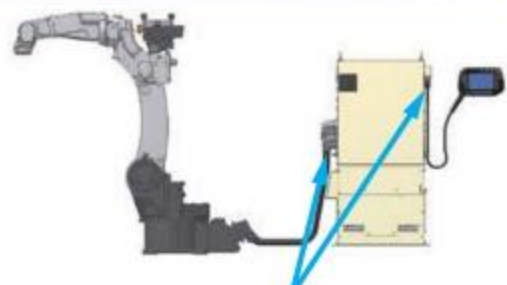

Cables with connectors on both ends

TAWERS WGII/WGHI

TAWERS Technology— Various Welding Processes

- **SP-MAGII** for short-circuit mixed gas welding on thin plates
- **HD-Pulse** for high-speed and low-spatter in high-current pulsed mixed gas welding
- **MTS-CO₂** for CO₂ welding

TAWERS Welding Process Guide

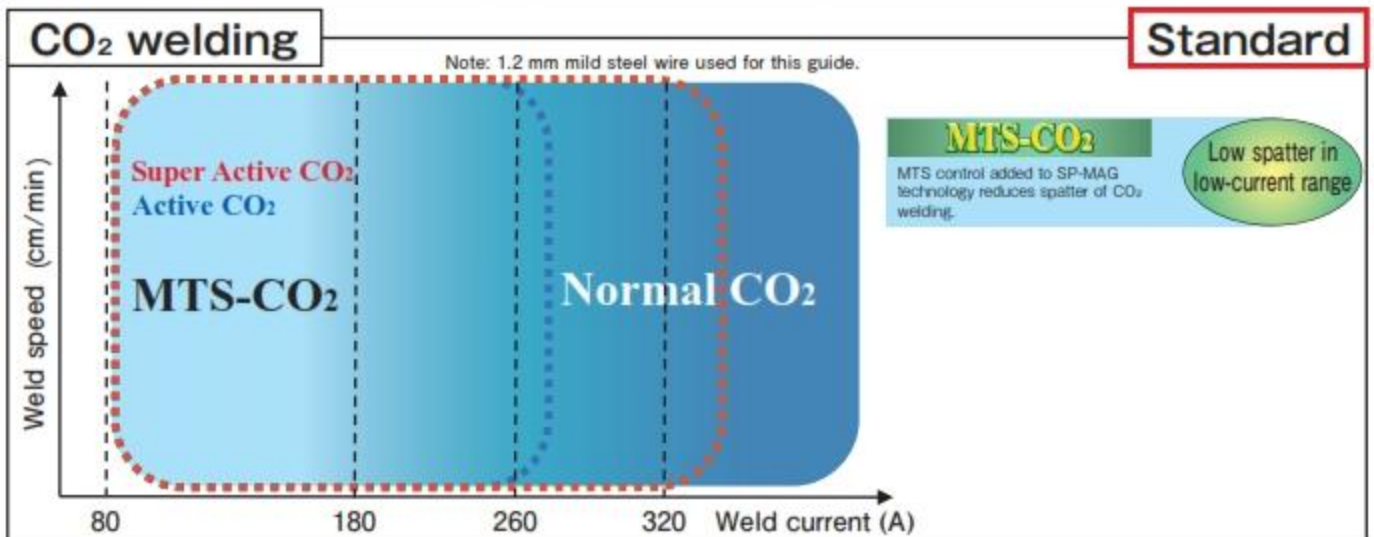
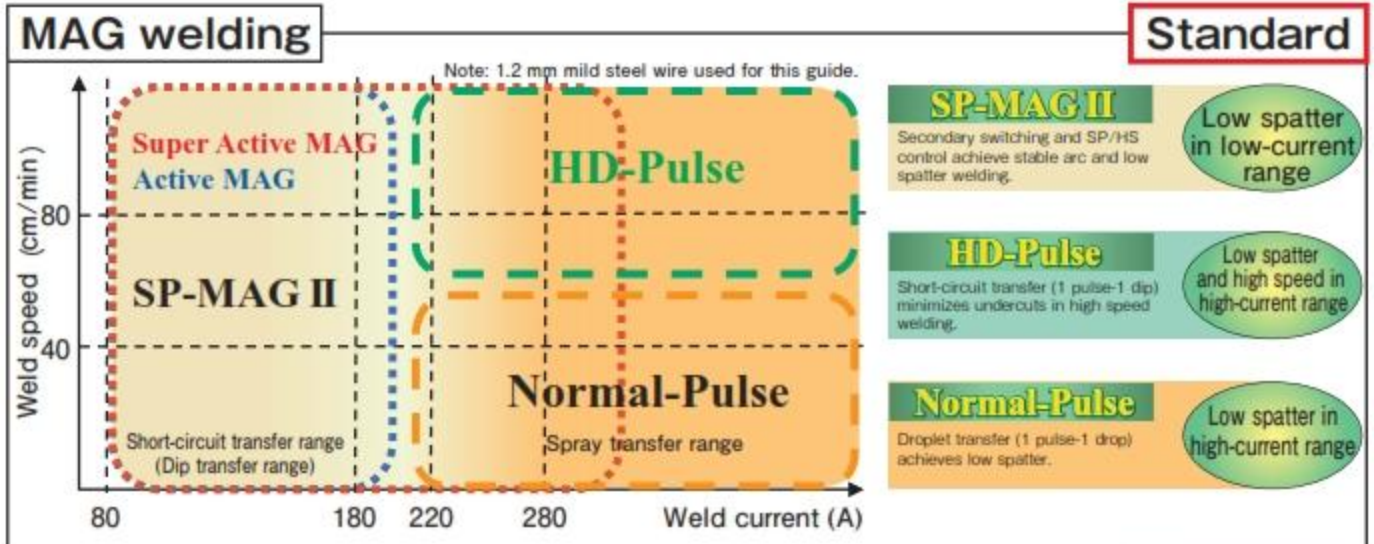

APPLICATION TYPE

Super Active TAWERS

NEW

Super Active Wire Feed Process

Achieves even lower spatter with high-precision control of wire feed speed.

Super Active MAG
Super Active CO₂



See the page of "Super Active TAWERS" for details.

TAWERS WGII/WGIII

TAWERS Technology— Various Welding Processes

- SP-MAGII for short-circuit mixed gas welding on thin plates
- MTS-CO₂ for CO₂ welding

SP-MAG II

(Super-imposition Control)

Greatly reduces spatter in mixed gas (MAG) welding on thin plates

Welding waveform control achieves low spatter in short-circuit transfer range.

Spatter comparison (1 minute at 200 A)

Conventional welder (350GB2)

TAWERS (SP-MAG II)

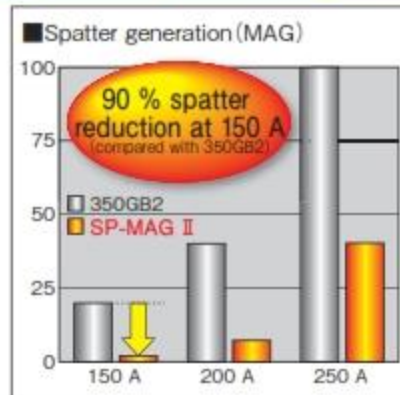
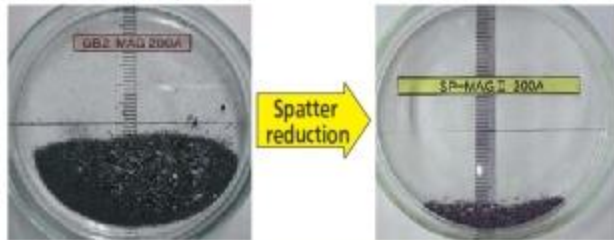

Recommended Panasonic wire YM-50MT used.



SP-MAG II current waveform

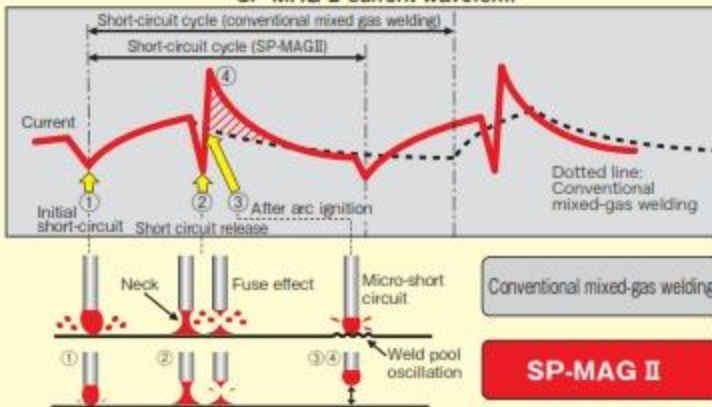

- 1 Initial short-circuit control**
Detects initial short-circuit and then the secondary switching* circuit reduces weld current rapidly to prevent micro-short circuit that causes spatter.
- 2 Neck control**
Detects a neck of the droplet and then the secondary switching* circuit reduces weld current rapidly to prevent fuse effect that causes spatter.
- 3 HS control**
Suppresses weld pool oscillation and prevents micro-short circuit that causes spatter.
- 4 SP control**
Superimposes the current immediately after a short-circuit release and allows for higher wire-melting speed. This makes the next short circuit smooth and also makes the short-circuit cycle shorter.

*Secondary switching is the spatter reduction process that rapidly reduces weld current immediately before and after short-circuit and allows for smooth transitions between arc and short circuit.

MTS-CO₂

(Metal Transfer Stabilization Control)

Reduces spatter by up to 75 % using inexpensive CO₂ gas

MTS control added to SP-MAG technology reduces spatter of CO₂ welding.

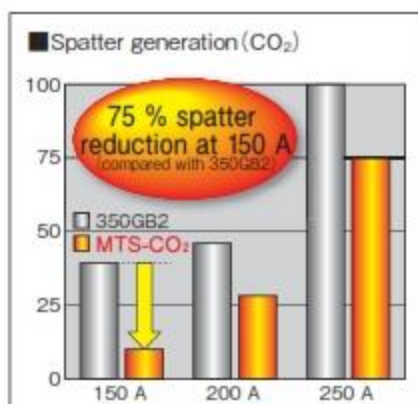

CO₂ welding delivers uniform pan-bottom shaped penetration.

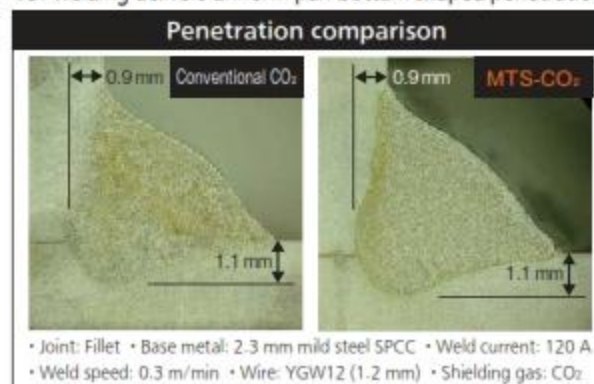

Conventional CO₂ process (350GB2)



MTS-CO₂



- Normal pulse for ultra-low spatter welding
- HD-Pulse for high-speed and low-spatter welding

HD-Pulse

(Hyper Dip-Pulse Control)

Achieves high-speed pulsed welding

Short and narrow arc prevents undercuts during high-speed welding.

HD-Pulse advantages:

- Preventing undercuts during high speed welding.
- Dip (Short circuit) transfer enabling lower heat input with better gap handling capability.
- Precisely controlled dip timing reducing spatter.

High speed welding

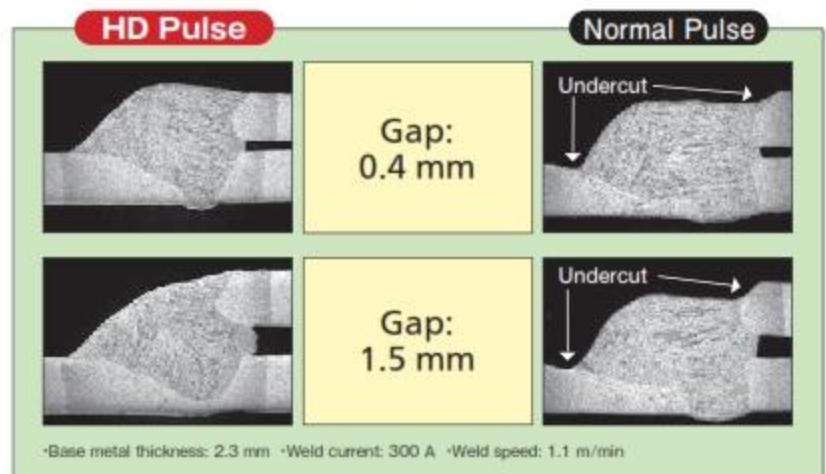

Preventing undercuts with ideal penetration!

Type of the droplet transfer

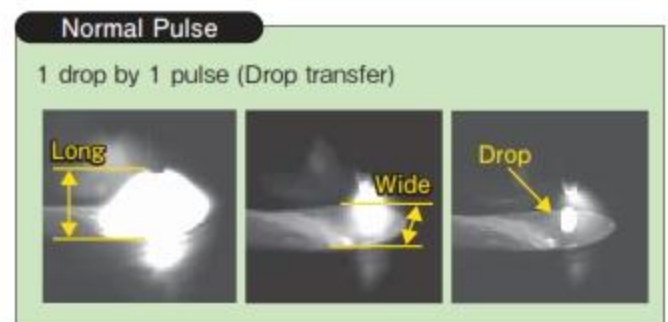
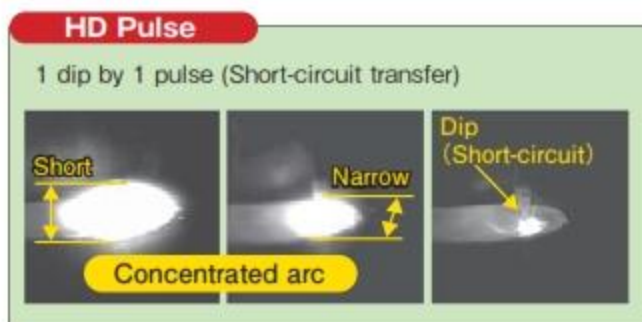

Spray transfer range: 280 A or more

Weld process	SP-MAG II	Normal-Pulse	HD-Pulse
Weld speed	good	good	excellent
Spatter	good-fair	excellent	good
Penetration pattern	fair	good-fair	excellent
Undercut	fair	fair	excellent
Heat input	fair	fair	good
Gap handling	fair	fair	good
Overall	fair	fair	excellent

- SP-MAG II disadvantage: Spatter in high-current range.
- Normal-pulse disadvantage: Undercuts in high-speed welding.

HD-Pulse process is ideal for high-current and high-speed welding.

TAWERS WGII/WGIII

Standard Features

External Communication (Ethernet)

Production and Quality Control on LAN

The LAN connection allows you to share welding data with other robots and improve production and quality control.



Flying Start

Executes arc-on/off programs a little before the torch reaches the weld start/end point to reduce cycle times.

Standard Arc Start

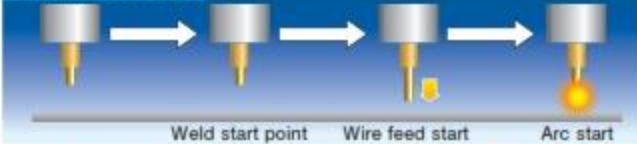

Flying Start

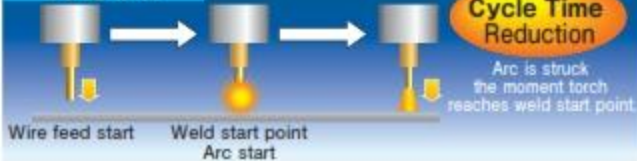

Wire Auto Retract

As the robot moves to weld start points, the wire is retracted automatically; thereby, improving arc start.



Wire Stick Auto Release (for CO₂/MAG)

Automatically detects a wire stuck at the end of a weld and re-ignites the arc to release the wire.

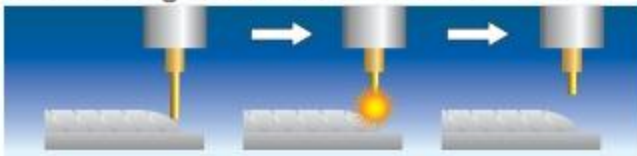

Pitch Movement ("Jog settings")

This function enables robot movement at a pre-set distance by every click of the jog dial. This is useful when working in narrow, constricted spaces or in fine-tuning robot position.



Lift Start / Lift End

Quality Weld Starts and Ends. Spatter and Cycle Time Reduction.

The robot lifts up the welding torch quickly at the start and end of the weld. By coordinating the robot motion with the welding waveform and wire feed control, quality and cycle time are improved. (Much quicker than wire retraction.)

Lift Start

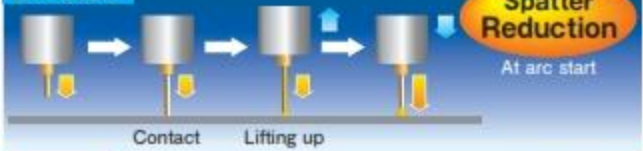

Lift End



Arc Start Retry (for CO₂/MAG)

Detecting a failure of arc start, the robot automatically starts arc ignition again.



Torch Angle Display (Teach Pendant)

Torch angle is displayed on the screen, making it possible to reduce teaching time and obtain consistent bead appearance.



Program Test

In Teach mode, operator can safely verify taught program including welding without switching to Auto mode.



TAWERS WGII/WGHI

Optional Features

Weld Data Management

Big progress toward ideal production and quality control. Samples weld data with a interval of up to 50 micro seconds, allowing high-precision monitoring and status/error output. The data can be stored and used for quality control.

Weld Monitor

Standard

Monitors data such as weld current, voltage and wire feed speed constantly and warns when abnormality is detected.

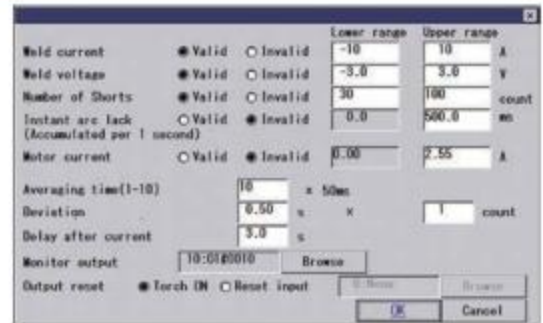

Weld Data Management

Optional Software

- Weld Monitoring (Expanded function)
Up to 50 weld monitoring conditions can be defined.
- Weld Data Logging/Recording
Data such as weld current, voltage and wire feed speed can be logged according to the preset triggers. The log data can be graphed on the teach pendant and recorded on SD memory card.

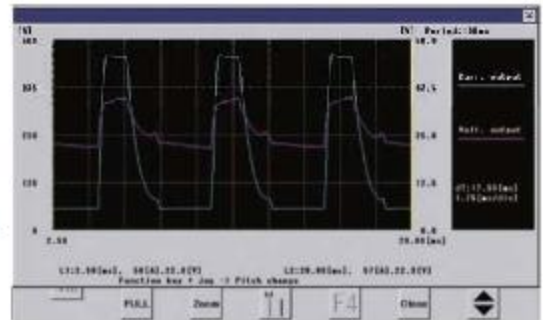

Welding Data Log

Optional Software

Logs data of weld sections. The log data can be saved for analysis.

Example of log data analysis

Wire target position misalignment caused by production lot change

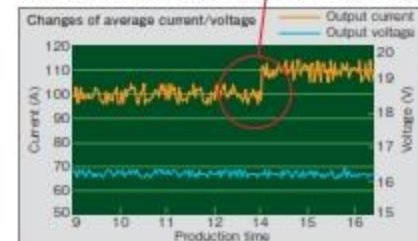

Available for defect rate reduction

More advanced welding system available

Utilize features such as external communication and large capacity memory.

Auto Extension Control

Optional Software

Compensates heat distortion or teaching error of odd-shaped work.

Robots detects changes in wire extension and compensates automatically.

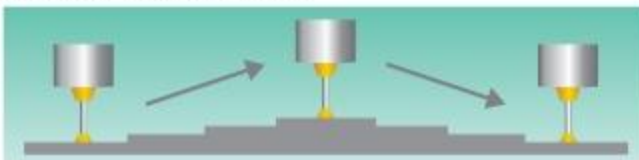

Cooperative Multi-Robot Control

Allows cooperative control between two robots.

Synchronous Weaving Low Pulse (Spiral Weaving Included)

[Spiral weaving movement]

Torch movement

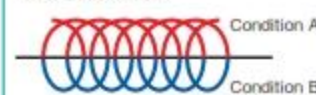

Weld current



Wire feed speed



•Synchronizes weld current, wire feed speed and weaving completely.

•Alternates condition A/B during weaving, which is ideal for welding of different thickness plates. (One for thin plate, the other for thick plate)

Small Type Arc Welding Robots

TS Series

NEW

**Payload:
8 kg**
TS-800/950



TS-800

TS-950

Succeed TAWERS' welding performance

● Various welding styles

Super Active TAWERS / TAWERS-TIG / TAWERS or others

【TW axis: Hollow arm】

Torch type selectable between through-arm and external



【Separate wire feeder】
Free layout

Improve small work productivity

● Space saving

48 % smaller footprint

(example of one customer, compared with our TM-1100)

Floor/Wall/Ceiling mount

(Ceiling mount type is special specification.)

● High speed despite 8 kg payload

Maximum motion speed: 540°/s
(average for all axes)

Dimensions & Work Envelope

For working envelope of point O, consult us.

(Unit: mm)

**Short Type
TS-800**

**Short Type
TS-950**

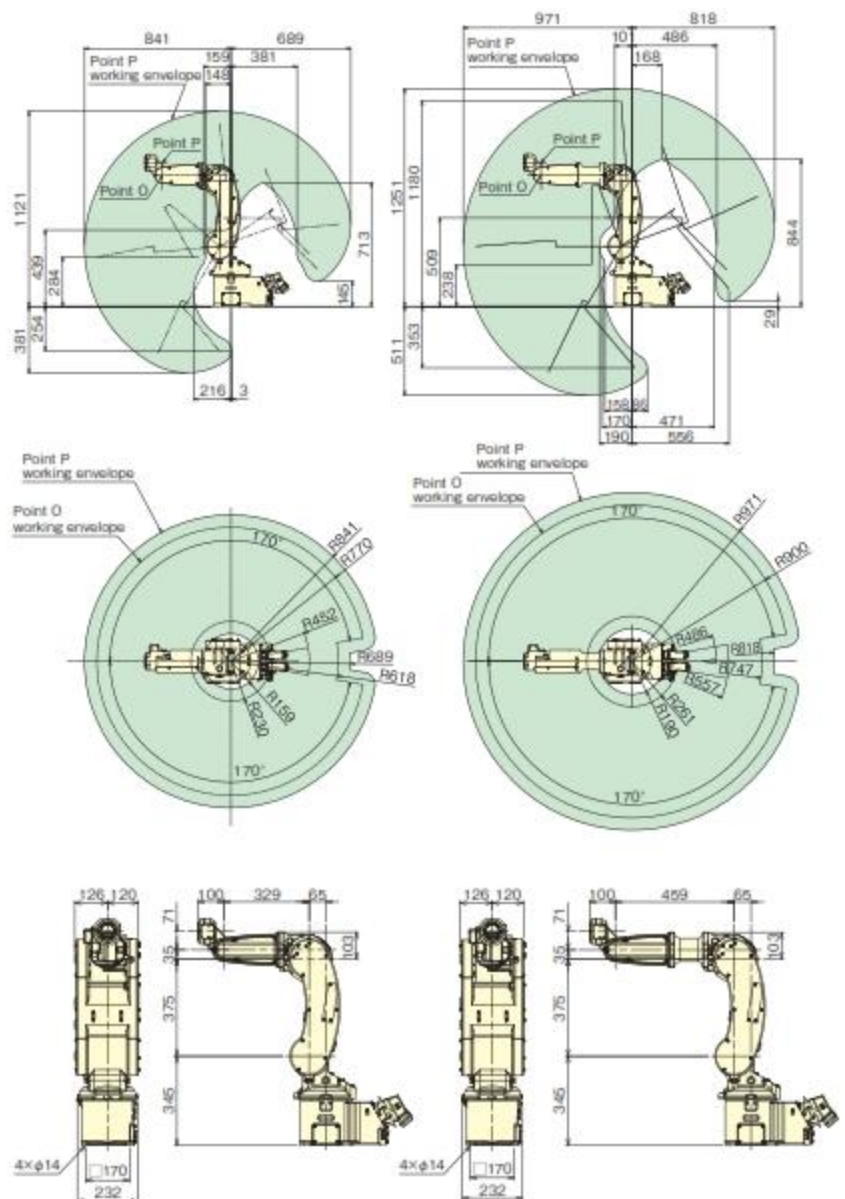

■ Manipulator General Specifications

Model	TS-800	TS-950
Type	Short arm	Short arm
Structure	6 axis articulated	
Payload	8 kg	
Maximum Reach	841 mm	971 mm
Minimum Reach	159 mm	190 mm
Working Range	682 mm	781 mm
Max. Motion Speed	RT (Rotating Trunk)	326°/s
	UA (Upper Arm)	326°/s
	FA (Forearm)	510°/s
	RW (Rotating Wrist)	518°/s
	BW (Bending Wrist)	518°/s
Position Repeatability	±0.05 mm	
	TW (Twisting Wrist)	
Motors	Total Power	2 100 W
	Brakes	All axes
Mounting	Floor/Ceiling*1/Wall*2	
Weight	55 kg	56 kg

*1: Ceiling mount type is factory optional.

*2: *Setting by service personnel is necessary. *Working range of RT axis is limited.

Dimensions & Work Envelope

(Unit: mm)

Short Type TM-1100

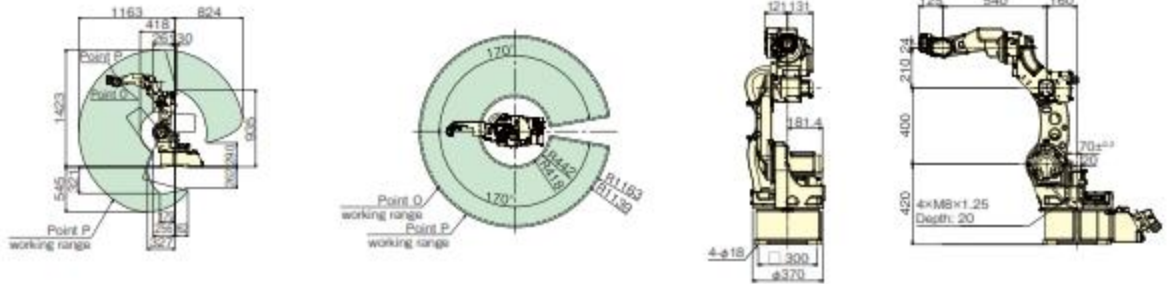

Standard Type TM-1400

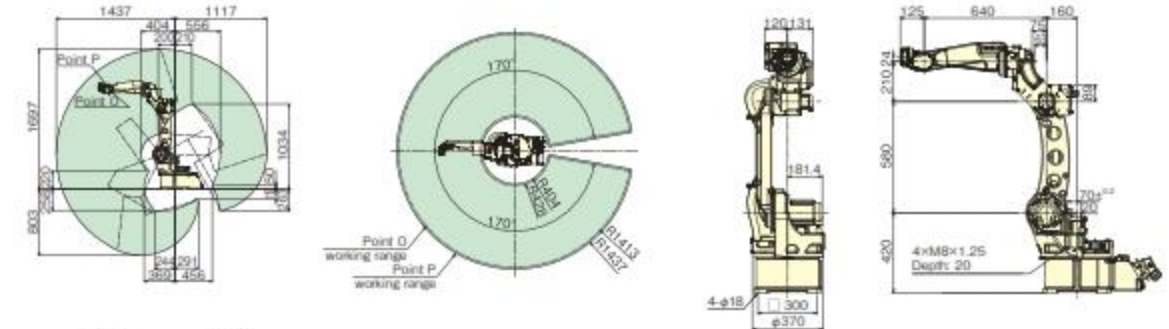

Middle Type TM-1600

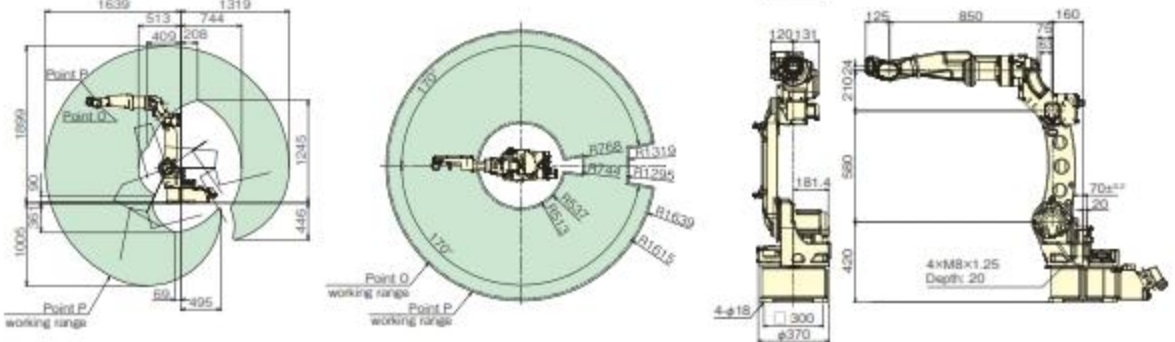

Long Type TM-1800

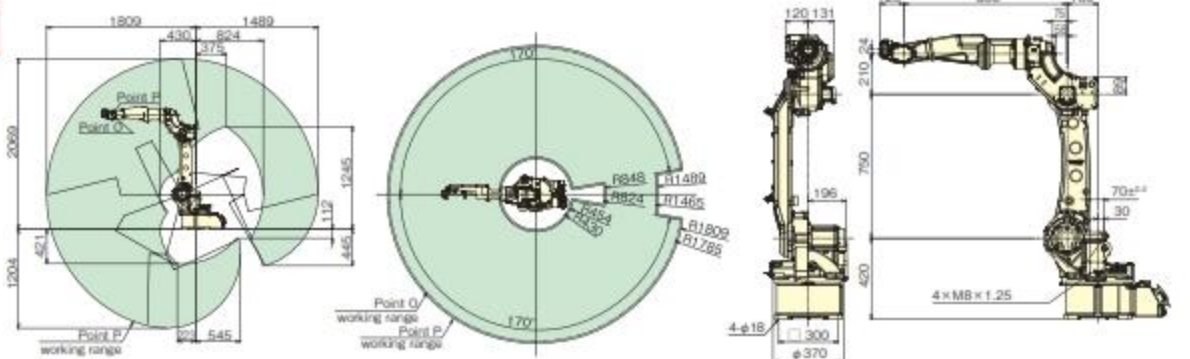

Manipulator General Specifications

Model	TM-1100	TM-1400	TM-1600	TM-1800	TM-2000	TL-1800	TL-2000
Type	Short arm	Standard arm	Middle arm	Long arm	Long arm	Long arm	Long arm
Structure	6 axis articulated						
Payload	6 kg		4 kg	6 kg		8 kg	6 kg
Maximum Reach	1 163 mm	1 437 mm	1 639 mm	1 809 mm	2 011 mm	1 801 mm	1 999 mm
Minimum Reach	418 mm	404 mm	513 mm	430 mm	550 mm	383 mm	491 mm
Working Range	745 mm	1 033 mm	1 126 mm	1 379 mm	1 461 mm	1 418 mm	1 508 mm
Max. Motion Speed	RT (Rotating trunk)	225°/s		210°/s	195°/s		195°/s
	UA (Upper arm)	225°/s		210°/s	197°/s		197°/s
	FA (Forearm)	225°/s		215°/s	205°/s		205°/s
	RW (Rotating wrist)	425°/s		425°/s	425°/s		385°/s
	BW (Bending wrist)	425°/s		425°/s	425°/s		375°/s
	TW (Twisting wrist)	629°/s		629°/s	629°/s		624°/s
Position Repeatability	±0.08 mm				±0.10 mm		±0.08 mm ±0.15 mm
Motors	Total Power	3 400 W			4 700 W		5 050 W
	Brakes	All axes					
Mounting	Floor / Ceiling*						
Weight	156 kg	170 kg	180 kg	215 kg	217 kg	215 kg	216 kg

*Ceiling mount type is factory optional.

Dimensions & Work Envelope

(Unit: mm)

Long Type TM-2000

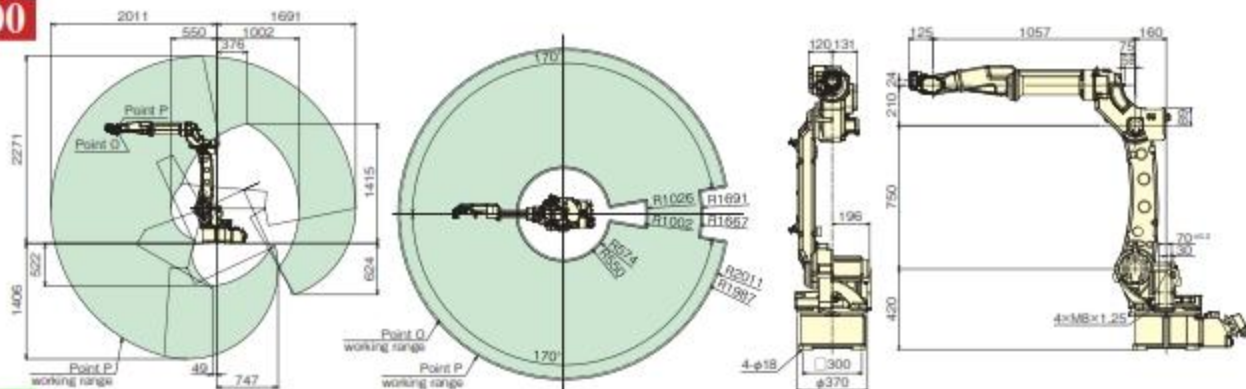

Long Type TL-1800

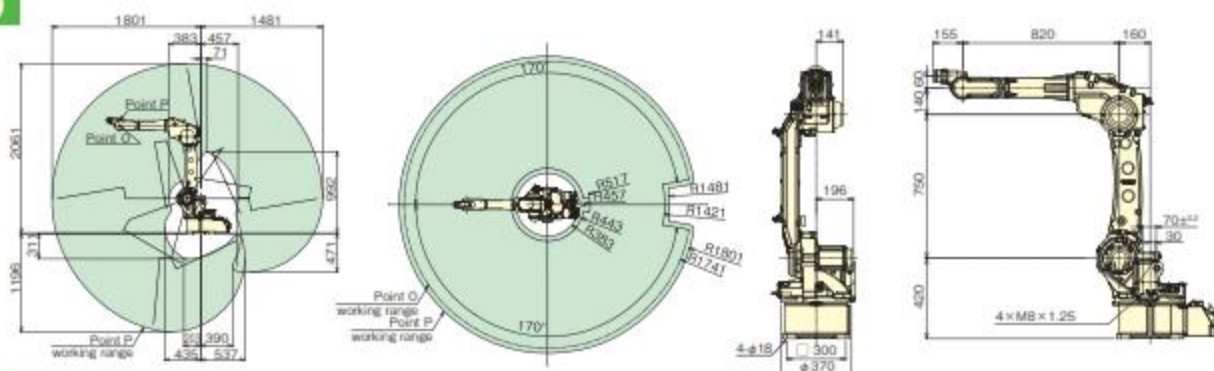

Long Type TL-2000

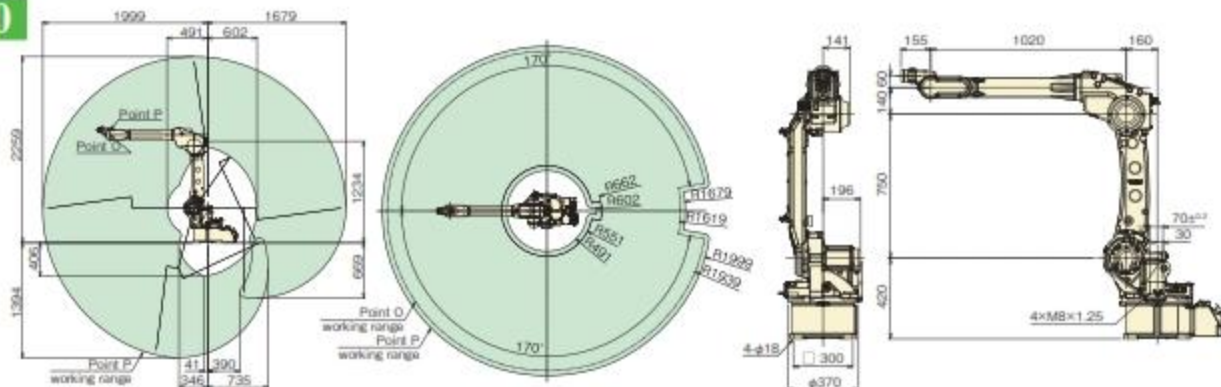

Controller / Welder Technical Specifications

Model	WGIII	WGHIII
Dimensions*	W 553 mm x D 550 mm x H 1181 mm	W 553 mm x D 550 mm x H 1407 mm
Weight**	135 kg	171 kg
Memory Capacity	40 000 points	
Position Control	Software servo control	
External Memory	Teach Pendant: one SD memory card slot, two USB 2.0 ports (USB 2.0. Hi-Speed not supported)	
Control Axes	6 axes simultaneously (Max. 27 axes)	
Input and Output	Input: 40 points (Optionally expandable up to 2048 points) Output: 40 points (Optionally expandable up to 2048 points)	
Input Power	3 phase, 200 V AC±20 V AC, 22 kVA, 50/60 Hz	3 phase, 200 V AC±20 V AC, 30.5 kVA, 50/60 Hz
Welding Process	CO ₂ / MAG / Stainless steel MIG / Pulse MAG / Stainless pulse MIG	
Output Current Range	30 to 350 A DC	30 to 450 A DC
Output Voltage Range	12 to 36 V DC	12 to 42 V DC
Duty Cycle	CV: 80 % @ 350 A Pulse: 60 % @ 350 A	100 %

Controller (with power unit)



Teach Pendant

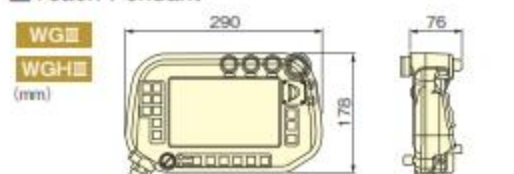

17 *Protruding portions not included. **Teach pendant and connection cable not included.
Note: For details on the power connection, refer to "Connecting primary power source" in the arc welding robot controller manual.

TM-1400WGIII (Separate Type)

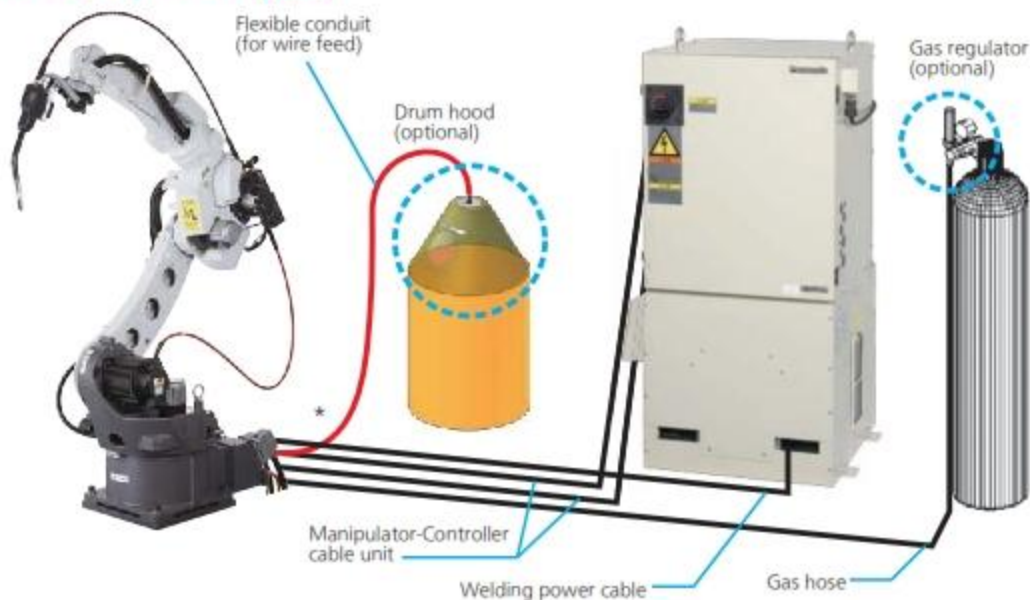

*For use with drum packing wire only.

Large Robot Series (GIII Controller)

Great material handling capability!

Coordinated multi-robot movement for flexible system without jig.



● Coordinated movement with WGIII/GIII robot(s)



Allows to build flexible system without jig.

Maximum configuration:
 •Arc welding robot x 2
 •Large robot x 1

● GIII controller for large robots

Same operation, maintenance and options as conventional robots

■ Manipulator General Specifications

Model	YS-080GIII	HS-220GIII		
Type	6 axis articulated robot			
Payload	80 kg	220 kg		
Working Range	RT (Rotating trunk)	±180°	±178°	
	UA (Upper arm)	-80° ~ +155°	-65° ~ +80°	
	FA (Forearm)	Referenced from Horizontal	-140° ~ +230°	-130° ~ +230°
		Referenced from upper arm	-80° ~ +180°	-73° ~ +190°
	RW (Rotating wrist)	±360°	±360°	
Max. Motion Speed	BW (Bending wrist)	±125°/s	±128°/s	
	TW (Twisting wrist)	±360°/s	±360°/s	
	RT (Rotating trunk)	170°/s	120°/s	
	UA (Upper arm)	140°/s	105°/s	
Position Repeatability	FA (Forearm)	160°/s	110°/s	
	RW (Rotating wrist)	230°/s	145°/s	
	BW (Bending wrist)	230°/s	145°/s	
	TW (Twisting wrist)	350°/s	220°/s	
Weight	±0.15 mm			
	645 kg	955 kg		