



THERA 650



## LIFTING MECHANISM

with 4-post lifting units which guarantee a consistently high level of sealing quality due to evenly distribution of the sealing pressure.

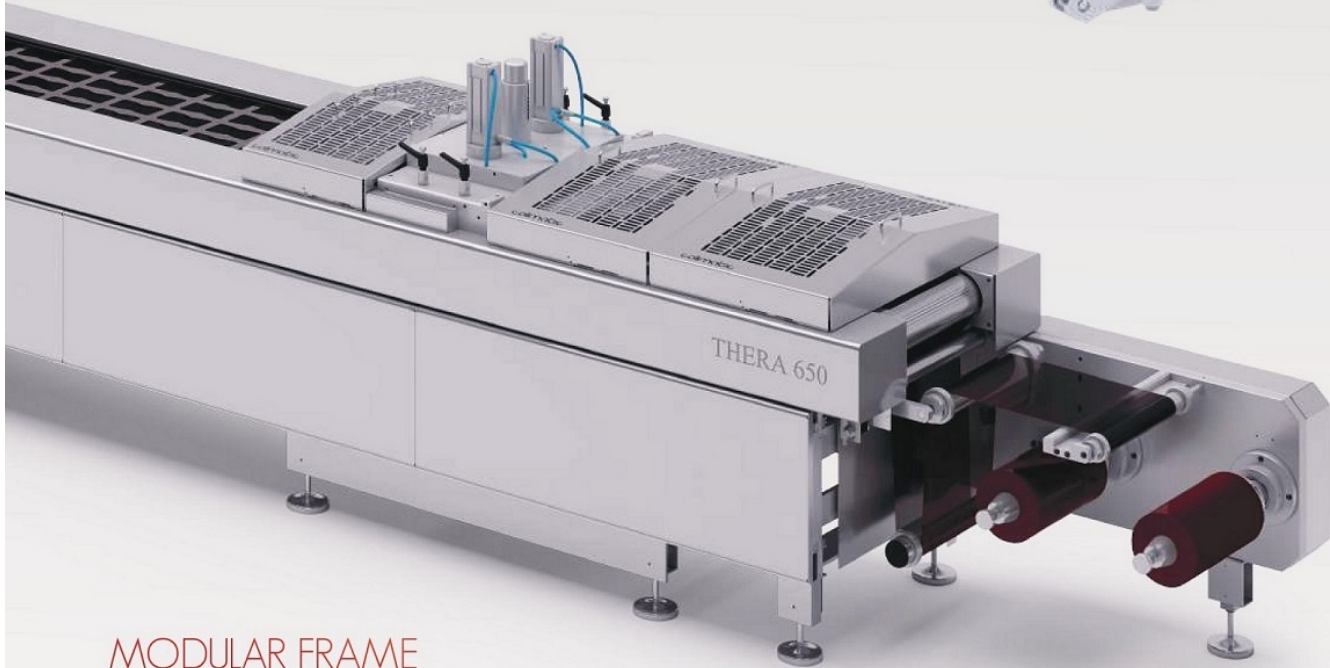
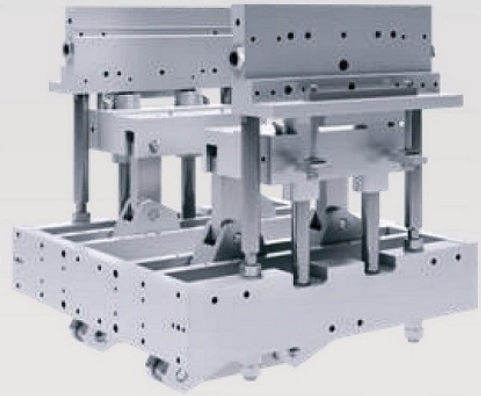

## MODULAR FRAME

to ensure the highest level of flexibility, with modular construction, uncompromisingly tailored to customers applications of today and still remain open to the demands of tomorrow.

## HINGED CHAMBERS

with folding opening device to allow the fastest format change, cleaning & maintenance operations.

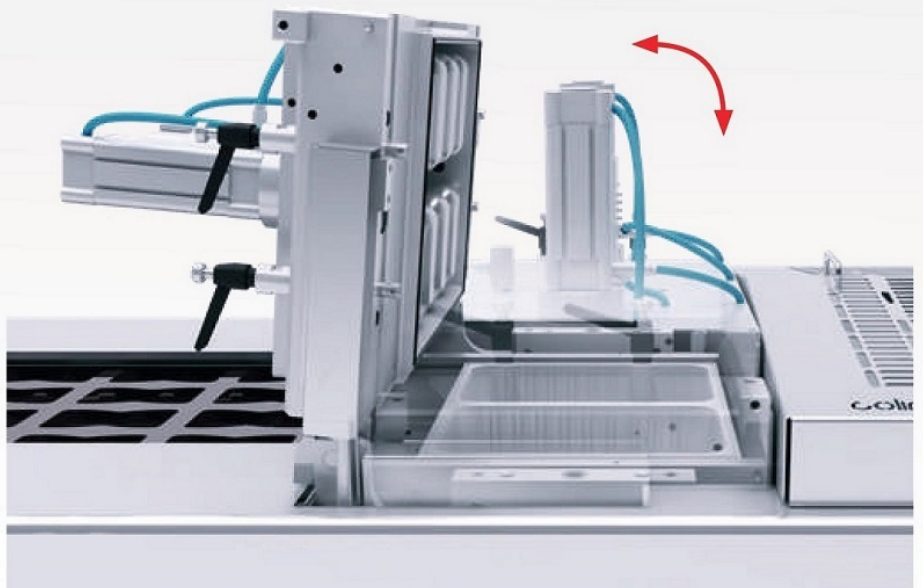

# OPTIONALS

- Double upper and lower film reelholder

- Automatic adjustment of packs depth
- Forming station adjusting device

- Integral cutting system
- Hydraulic cutting systems
- In line folding device for wallet-packs

- L.I.S.A.® connect
- CFR21 software integration
- Vision systems

- External components integration service

- Customer's logo embossed

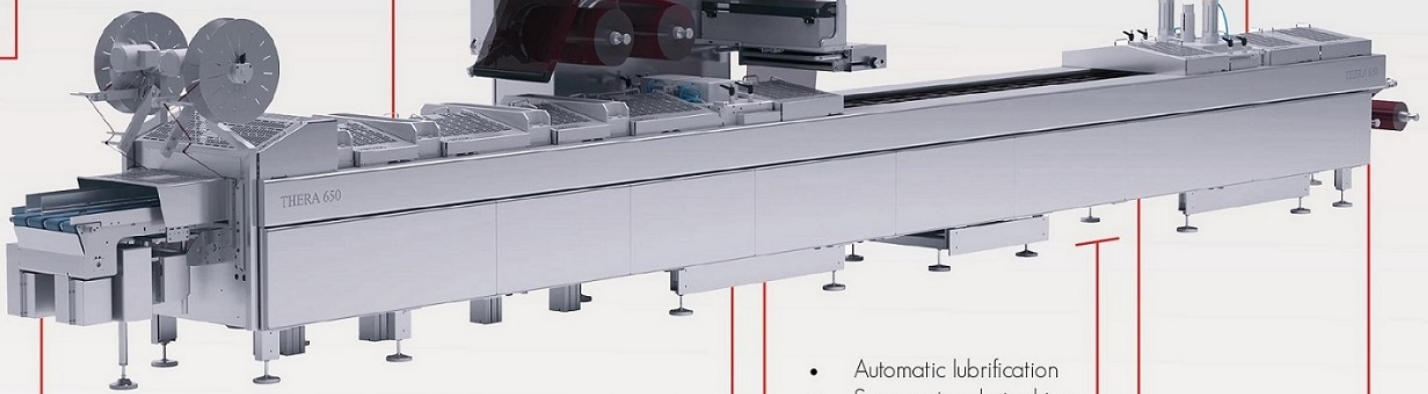

- Integrated printing and labelling systems
- Reclosable top film application

- Automatic lubrication
- Servomotor chain drive system

- High hygiene components set

- Liquid and creamy product dosing systems
- Automatic loading devices
- Integrated pick&places systems

- Aligning devices
- Output conveyors



- Jumbo reelholder