



Twin-Headed Rocking Piston

Model: ZW300A-75/1.4-HK008



- Permanently lubricated bearings
- Oil-less, non-lubricated cup and cylinder
- Long-life cup design
- Thin wall cylinder for good heat transfer
- Stainless-steel valves
- Field Service ability
- ISO 9000 registered
- RoHS & REACH compliant
- Other voltages and configuration available upon request

Specifications

Input Voltage / Frequency	220 V / 50Hz
Max Open Flow	95 LPM
Max Vacuum	-800 mbar
Rated Flow Rate	75lpm @1.4 bar
Max Intermittent Pressure	2 bar
Pressure Restart Capability	N/A
Rated Input Power	370W@1.4 bar
Current at Rated Load	1.7A @1.4 bar
Noise Level	57 dB
Ambient Temperature	10°C to 40°C
Starting Current	4.5 Amp
Recoverable Thermal Protector	135°C ±5%
Capacitor value	10uF, 450VAC
Weight	5.5 Kg
Motor type	PSC

Flow Curve

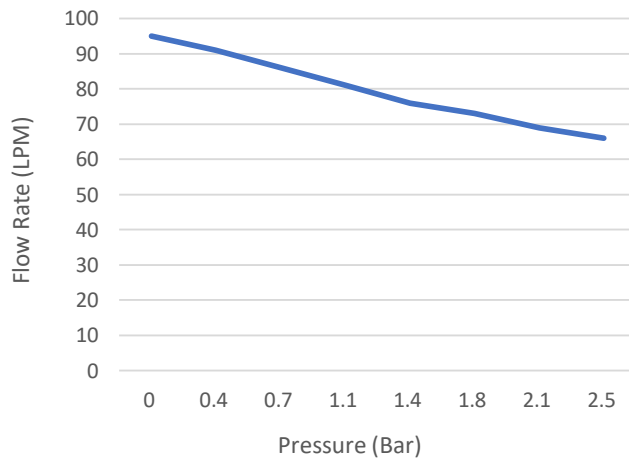

Dimensions

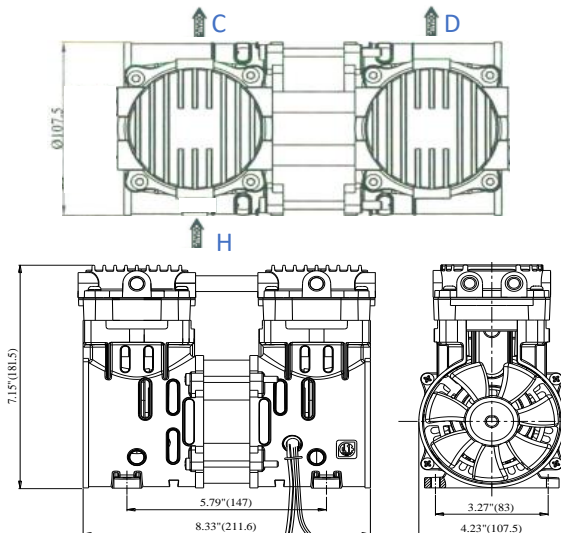

Configuration

Power leads	700mm (Black, Black)
Capacitor leads	370mm (Red, Red)
Ground wire	N/A
Power Socket / Terminal	N/A
Pressure Relief valve	N/A
Intake Filter	N/A
Shock mount	N/A
Capacitor	∅ 34 x 82, Mounted
Fan Guard	N/A
Foot Mount Tap	4 x M6
Elbow Fitting	Port "D" & "H"
All Tapped Port	M12 x 1.25
Intake Port	Port "H"
Exhaust Port	Port "C" & "D"
Cooling air direction	Toward motor
Surface finish	No painting