

REDUREX-Stirnradgetriebe dreistufig mit Fuß Bauart SDN

REDUREX triple reduction helical gear units with feet Type SDN

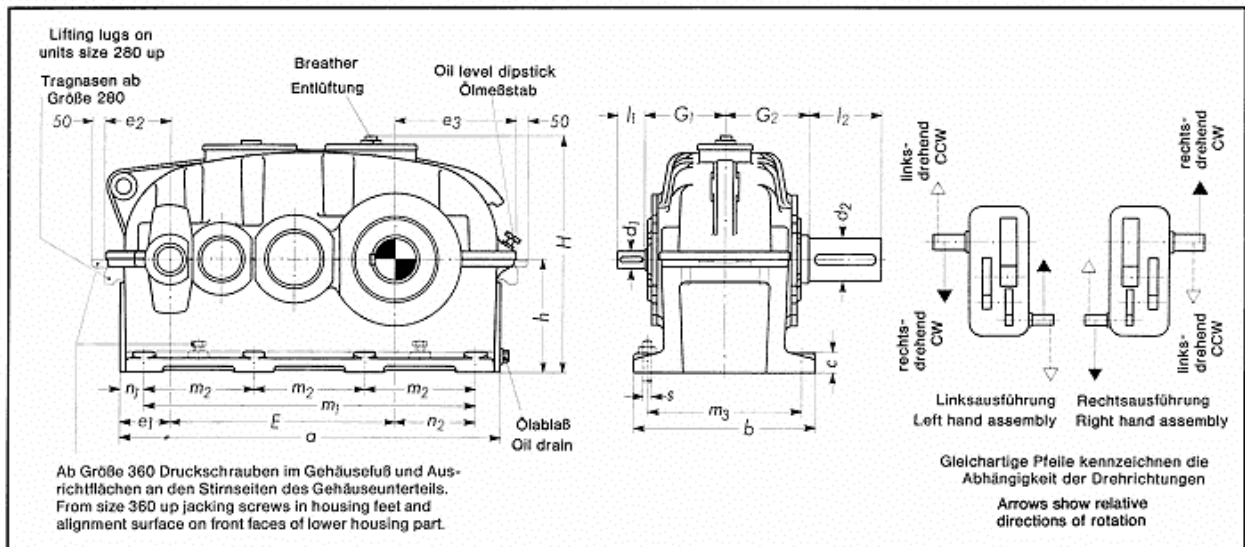

Maße, Gewichte und Ölmengen **Dimensions, weights and oil quantities**

Bauart Type SDN Größe Size	a mm	b mm	c mm	Wellenende ¹⁾ Shaft end ¹⁾		d ₁ mm	l ₁ mm	d ₂ mm	l ₂ mm	E mm	e ₁ mm	e ₂ mm	e ₃ mm	G ₁ mm	G ₂ mm	h mm	H mm
				i _N = 22,4-71	i _N = 80-100												
160	600	290	32	24 k6	40	19 k6	35	75 m6	120	352	83	107	188	130	140	180	375
180	665	320	32	28 m6	50	22 k6	35	85 m6	140	395	85	109	209	145	155	200	415
200	745	355	40	32 m6	60	22 k6	35	95 m6	160	440	97,5	128	238	160	170	225	462
225	840	390	40	38 m6	60	24 k6	40	100 m6	180	497	110,5	141	263	175	190	250	511
250	930	450	50	42 m6	70	32 m6	60	110 n6	180	555	120	158	293	200	215	280	570
280	1025	500	50	48 m6	80	38 m6	60	130 n6	210	620	120	160	325	225	240	315	644
320	1160	570	63	48 m6	80	42 m6	70	140 n6	240	705	140	189	364	255	270	355	719
				i _N = 20-35,5		i _N = 40-90											
360	1280	600	63	60 m6	105	48 m6	80	170 n6	270	790	140	188	398	275	290	400	806
400	1420	690	80	65 m6	105	55 m6	90	180 n6	310	880	155	215	445	305	320	450	906
450	1610	750	80	70 m6	120	60 m6	105	210 n6	350	995	175	240	505	345	360	500	1006
				i _N = 20-45		i _N = 50-90											
500	1790	830	100	80 m6	140	65 m6	105	240 n6	400	1110	200	277	557	385	400	560	1121
560	2010	910	100	95 m6	160	75 m6	120	270 n6	450	1240	235	324	624	400	440	630	1261
630	2260	1030	125	110 n6	180	85 m6	140	300 n6	500	1400	255	344	694	460	500	710	1406
710	2540	1160	125	120 n6	210	90 m6	160	340 n6	550	1570	295	400	780	520	560	800	1581
800	2850	1320	160	140 n6	240	100 m6	180	390 n6	650	1760	335	448	868	595	645	900	1783

Bauart Type						Fußschrauben Found. bolts		Gewicht Mittelwert Average weight kg	Öl- Höchstmenge Max. oil quantity Liter litres
SDN	m ₁	m ₂	m ₃	n ₁	n ₂	s	Anzahl No. off		
Größe Size	mm	mm	mm	mm	mm	mm			
160	510	170	245	45	120	M 16	8	150	10
180	570	190	275	47,5	137,5	M 16	8	205	14
200	630	210	300	57,5	150	M 20	8	285	19
225	705	235	335	67,5	165	M 20	8	390	26
250	810	270	380	60	195	M 24	8	540	36
280	855	285	430	85	200	M 24	8	750	53
320	960	320	490	100	215	M 30	8	1050	75
360	1080	360	520	100	250	M 30	8	1400	115
400	1200	400	590	110	275	M 36	8	1950	160
450	1350	450	650	130	310	M 36	8	2650	220
500	1500	500	710	145	335	M 42	8	3800	300
560	1680	560	790	165	370	M 42	8	5100	450
630	1890	630	890	185	420	M 48	8	7200	520
710	2130	710	1000	205	470	M 48	8	10800	820
800	2400	800	1140	225	530	M 56	8	14000	1150

Größere Getriebe auf Anfrage
 1) Wellende mit Paßfeder nach DIN 6885 Teil 1 Form A und Zentrierung nach DIN 332 Form DS
 Larger gear units against enquiry.
 1) Shaft end with parallel key to DIN 6885/1 form A and tapped centering hole to DIN 332 form DS

SDN/O/A