



Kodak

ThermoFlex Wide II

Output Device

Site Preparation Guide
English

Copyright

© Kodak, 2007. All rights reserved.

Kodak, Creo and ThermoFlex are trademarks of Kodak.

Acrobat, Adobe, Distiller, Illustrator, PageMaker, Photoshop, and PostScript are trademarks of Adobe Systems Incorporated.

Apple, AppleShare, AppleTalk, iMac, ImageWriter, LaserWriter, Mac OS, Power Macintosh, and TrueType are registered trademarks of Apple Computer, Inc. Macintosh is a trademark of Apple Computer, Inc., registered in the U.S.A. and other countries.

Hexachrome, PANTONE, PANTONE Hexachrome, and PANTONE MATCHING SYSTEM are the property of Pantone, Inc.

PEARL, PEARLdry, PEARLgold, PEARLhdp, and PEARLsetter are registered trademarks of Presstek, Inc.

XEROX is a trademark of XEROX CORPORATION.

<http://graphics.kodak.com/>

Internal 725-00093A-EN Rev D

Revised June 2007

Contents

ThermoFlex Wide II Site Preparation Guide	1
Introduction	1
Tools Needed.....	1
Equipment Overview	2
Size and Weight.....	3
Cables, Connectors, and Receptacles	4
Site Requirements	9
Footprint and Working Area.....	9
Debris Removal Cabinet.....	10
Environmental Conditions.....	11
Floors	11
Floor Vibration.....	12
Electrical.....	13
Power Quality	13
Special Precautions	13
Heat Output	14
Power Line Voltage/Frequency	14
Power Line Disturbances	14
Air Supply	15
Ventilation.....	15
External Venting for Debris Removal System	16
Drum Vacuum System.....	17
Drum Vacuum Pump	17
Drum Vacuum Drive	18
Telephone Link	20
Network	20
Media and Processor(s)	20
Shipment and Delivery	21
Responsibilities	21
Forklift.....	21
Doors and Hallways	22
Shipping Crates.....	23
Appendix A:Notice	25
Appendix B:Site Inspection Checklist	27

ThermoFlex Wide II Site Preparation Guide

Introduction

Please take a few moments to read through this document. It provides guidelines for preparing your site for the Kodak® ThermoFlex® Wide II platesetter installation.

Your service representative will help you to ensure that your site meets all the requirements. Proper preparation will help to prevent unnecessary problems and delays when installing the device.

The following topics are discussed:

- Device configuration
- Floor space requirements
- Device dimensions
- Weight requirements
- Electrical requirements
- Debris removal system requirements
- Environmental conditions
- Ventilation requirements
- Network/modem requirements
- Processor specifications

With your service representative, complete the *Site Inspection Checklist* in Appendix B.

Tools Needed

- Microscope (100X recommended)
- Dotmeter: Centurfax CCDot, BetaFlex 330 or equivalent
- Press sheet densitometer (recommended): GretagMacbeth® D19C or D196, X-Rite® 400 series, Tobias IQ150. All with relative density and dot area (Murray-Davies) functions.

Equipment Overview

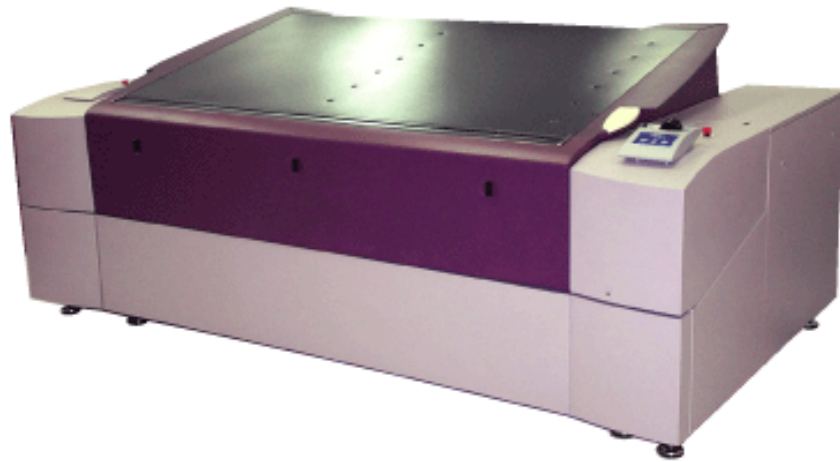

The device consists of the following standard components:

- Plate recording output device
- Very high power 2400 dpi thermal imaging head
- Drum vacuum system
- Debris removal system¹ and thermal head cooling systems

Plus the following options:

- Sleeve capability, including the Quick Change Drum Exchange System
- One universal sleeve arbor
- Sleeve toolkit (hardware and software)
- Sleeve load/unload production hub
- “One-touch” semi-automatic sleeve load/unload system, including modified processor shafts
- Sleeve transport cart

1. The debris removal system consists of a vacuum pump and filtration system for removing debris from exposed media. Refer to the *UDRC Site Preparation Guide* (part number 725-00089A).

Size and Weight

Table 1 shows the maximum dimensions and weight of the ThermoFlex Wide II components. The measurements are taken facing the ThermoFlex Wide II system, with the panels installed. Width is in the x-axis direction. Depth is in the y-axis direction.

For measurements of the crates as shipped, see *Shipping Crates* on page 23.

Table 1: Size and weight of ThermoFlex Wide II device

Component	Width	Depth	Height	Weight
Base unit	3338 mm (131 in.)	1891 mm (74 in.)	1391 mm (55 in.)	1727 kg (3800 lb.)
Chiller	380 mm (15 in.)	600 mm (23.5 in.)	660 mm (26 in.)	73 kg (160 lb.)
Drum vacuum drive	410 mm (16 in.)	220 mm (8.5 in.)	530 mm (21 in.)	25 kg (55 lb.)
Drum vacuum pump	1440 mm (57 in.)	695 mm (27.5 in.)	520 mm (20.5 in.)	60 kg (132 lb.)
Pedestal	tbd	tbd	tbd	tbd
Transport cart	1900 mm (approx) (74.8 in.)	1100 mm (approx) (43.3 in.)	2000 mm (approx) (78.7 in.)	tbd
Debris removal cabinet	See the <i>UDRC Site Preparation Guide</i> (part number 725-00089A).			
Workstation	Varies with configuration			

Cables, Connectors, and Receptacles

Tables 2-4 list the supplied and required cables and connectors for the output device. Table 5 lists the power/air connections. An overview of the system connections is shown in Figure 1 on page 8.

Table 2: Cables and Interconnects—North America

Cables	Supplied by Kodak	Required by customer ^a
Output device main power	Attached 4.5 m (14.7 ft.) power cord with L6-30P plug	Dedicated 30 A, 200-240 V circuit (single phase) with L6-30R receptacle. The circuit breaker must be 30 A time-delay type.
Drum vacuum drive power	Labeled terminals for hookup of AC mains input cable (3-phase plus ground). Pilot hole for appropriate conduit fitting.	Dedicated 20 A, 340-506 VAC ($\pm 0\%$), 50/60 Hz, 3-phase branch circuit with circuit breaker protection. Wiring, circuit breaker and panel fittings supplied by customer in accordance with local electrical standards.
Workstation power	Detachable 2.5 m (8.2 ft.) power cable with 5-15P plug	Dedicated 15 A, 120 V branch circuit and 5-15R receptacle
Chiller power	2.5 m (8.2 ft.) power cable with 5-15P connector	5-15R receptacle and dedicated 120 V, 15 A branch circuit
Debris removal cabinet power	Refer to the <i>UDRC Site Preparation Guide</i> (part number 725-00089A).	
Telephone line	Modem and serial cable. The modem power supply can be plugged into a UPS.	Two dedicated telephone lines and RJ-11 cables to plug into modem (must be long enough to reach workstation). One line is to connect to the workflow, and the other is to connect to Kodak remote support.

- a. The tolerances for input voltages are +6%, -10%. The specification for the frequency is 50/60 Hz $\pm 1.5\%$. Branch circuits should have time delay type circuit breakers to avoid nuisance tripping caused by inrush currents. For details, see *Electrical* on page 13.

Table 3: Cables and Interconnects—Europe, Australia and S.E. Asia

Cables	Supplied by Kodak	Required by customer ^a
Output device main power	Attached 4.5 m (14.7 ft.) power cord with L6-30P plug	Dedicated 32A, 200-240 V circuit with IEC309 32 A/250 V receptacle and slow-blow circuit breaker
Drum vacuum drive power	Labeled terminals for hookup of AC mains input cable (3-phase plus ground). Pilot hole for appropriate conduit fitting.	Dedicated 20 A, 340-440 VAC ($\pm 0\%$), 50/60 Hz, 3-phase branch circuit with circuit breaker protection. Wiring, circuit breaker and panel fittings supplied by customer in accordance with local electrical standards.
Workstation power	IEC320, type C14 appliance inlet	IEC320, type C13 connector with 8 A cord Dedicated 8 A, 200-240 V branch circuit
Chiller power	2.5 m (8.2 ft.) power cable with 5-15P connector	Dedicated 120 V, 15 A branch circuit with 5-15R receptacle
Debris removal cabinet power	See the <i>UDRC Site Preparation Guide</i> (part number 725-00089A).	
Telephone line	Serial cable for modem	Two dedicated telephone lines and RJ-11 cables to plug into modem (must be long enough to reach workstation). One line is to connect to the workflow, and the other is to connect to Kodak remote support. Also requires separate AC power source (UPS provided only with IEC type 320 outlet receptacles).

- a. The tolerances for input voltages are +6%, -10%. The specification for the frequency is 50/60 Hz $\pm 1.5\%$. Branch circuits should have time delay type circuit breakers to avoid nuisance tripping caused by inrush currents. For details, refer to *Electrical* on page 13.

Table 4: Cables and interconnects—Japan

Cables	Supplied by Kodak	Supplied by customer ^a
Output device main power	Attached 4.5 m (14.7 ft.) power cord with L6-30P plug	Dedicated 30 A, 200 V branch circuit with slow-blow circuit breaker and L6-30R receptacle
Drum vacuum drive power	Labeled terminals for hookup of AC mains input cable (3-phase plus ground). Pilot hole for appropriate conduit fitting.	Dedicated 20A, 340-506 VAC ($\pm 0\%$), 50/60 Hz, 3-phase branch circuit with circuit breaker protection. Wiring, circuit breaker and panel fittings supplied by customer in accordance with local electrical standards.
Workstation power	2.5 m (8.2 ft.) power cable with 5-15P connector	5-15R receptacle and dedicated 100 V, 15 A branch circuit
Chiller power	2.5 m (8.2 ft.) power cable with 5-15P connector	5-15R receptacle and dedicated 120 V, 15 A branch circuit
Debris removal cabinet power	See the <i>UDRC Site Preparation Guide</i> (part number 725-00089A).	
Telephone line	Serial cable for modem.	Two dedicated telephone lines and RJ-11 cables to plug into modem (must be long enough to reach workstation). One line is to connect to the workflow, and the other is to connect to Kodak remote support. Also requires separate AC power source (UPS provided only with 5-15R receptacles).

- a. The tolerances for input voltages are +6%, -10%. The specification for the frequency is 50/60 Hz $\pm 1.5\%$. Branch circuits should have time delay type circuit breakers to avoid nuisance tripping caused by inrush currents. For details, refer to *Electrical* on page 13.

Table 5: Air and network connections

Other connections ^a	Supplied by Kodak	Required by customer ^b
Network connection (for connecting to the workflow)	Ethernet: 100 Base-T (RJ-45)	Network connection and cable long enough to reach workstation.
	FDDI: Duplex SC	3 consecutive IP addresses for the MCE and RAS connections, plus 1 IP address for the Local Area Network connection to the customer network
Drum vacuum pump hose	15.2 m (50 ft.) of 2 in. flexible vacuum tubing and 4 hose clamps	50.8 mm (2 in.) Schedule 40 PVC tubing for use where flexible hose is not required. See <i>Tubing (Pump to Output Device)</i> on page 18.
Chiller hose	2.5 m (8.2 ft.) long head coolant hose assembly between the external chiller and the output device	
Workstation interface	7.6 m (25 ft.) long SCSI and serial interface cables between the workstation and the output device	
Shop air supply (dedicated branch recommended—see <i>Air Supply</i> on page 15)	12.7 mm (0.5 in.) national pipe thread (NPT) female fitting on the device	<p>A flexible airline, 12.7 mm (0.5 in.) internal diameter minimum, with 12.7 mm (0.5 in.) male NPT fitting at the end for connection to the ThermoFlex Wide II.</p> <p>The air line <i>must</i> be capable of delivering 40 SCFM @ 100120 psi.</p> <p>Keep the airline as short as possible and free from restrictions. If the air line is longer than 6.1 m (20 ft.), use a larger internal diameter airline.</p>

a. For a diagram of system connections, see Figure 1 on page 8.

b. For the location of the air supply, see *Footprint and Working Area* on page 9. For further details, see *Air Supply* on page 15 and *Network* on page 20.

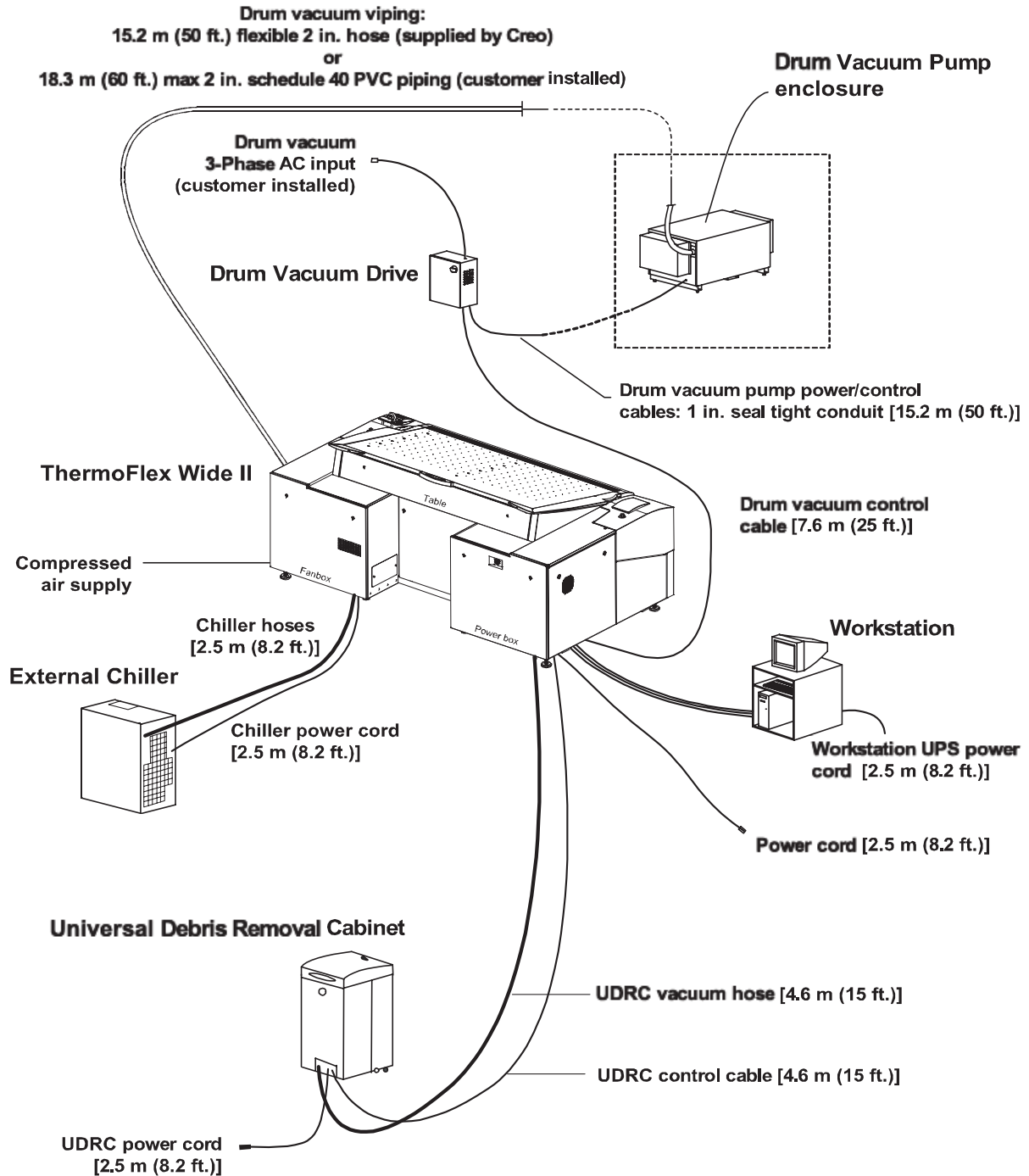

Figure 1: ThermoFlex Wide II system connections

Site Requirements

Footprint and Working Area

See Figures 2-3 for the recommended work area and dimensions. For operator and service access, leave at least 1067 mm (42 in.) clearance at the front of the device, and 910 mm (36 in.) clearance at the sides of the device.

The customer should provide an area close to the device for storing media (for immediate use), disks, paperwork, and so on.

Note: The workstation, debris removal cabinet, drum vacuum pump, and external chiller must not intrude into the service clearance zone around the perimeter of the output device.

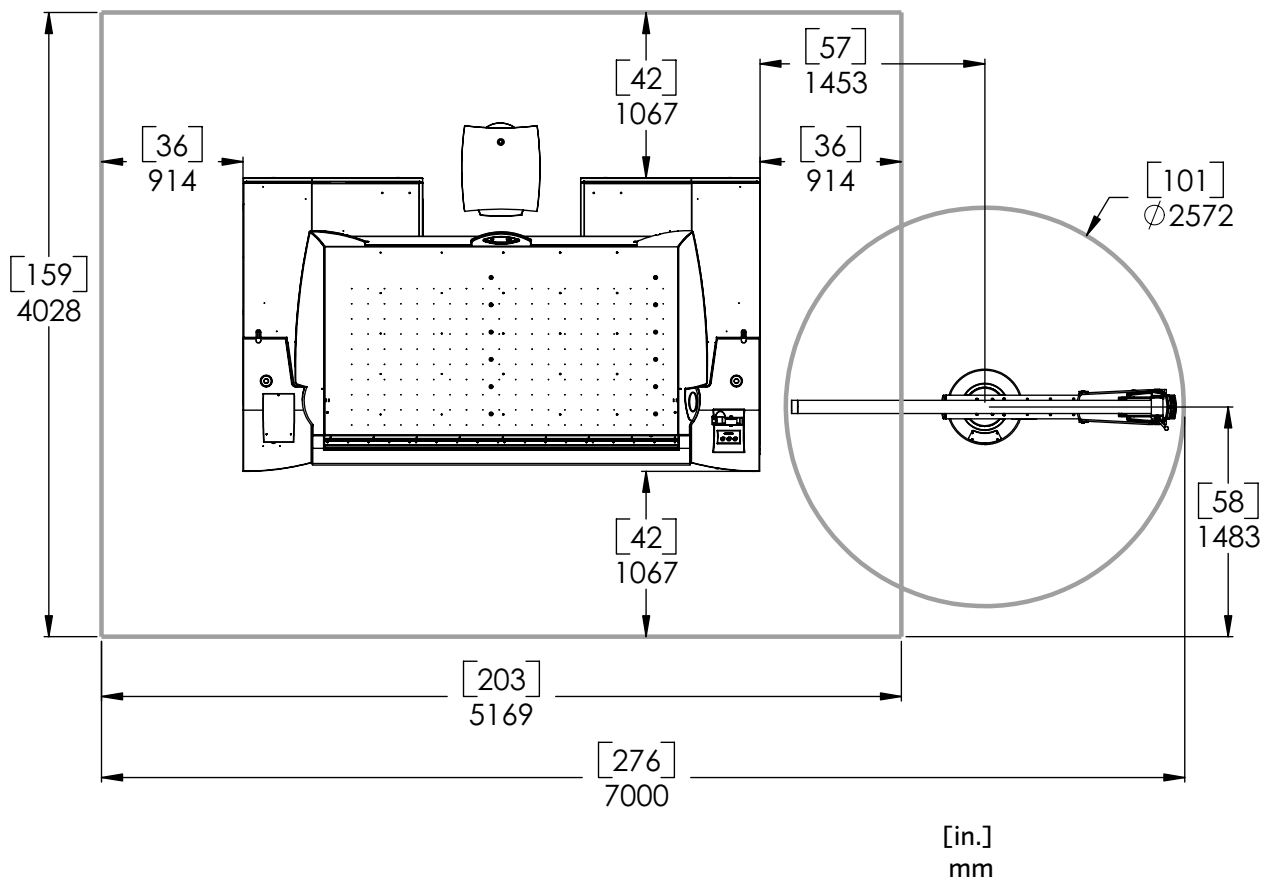

Figure 2: Top view of ThermoFlex Wide II work area

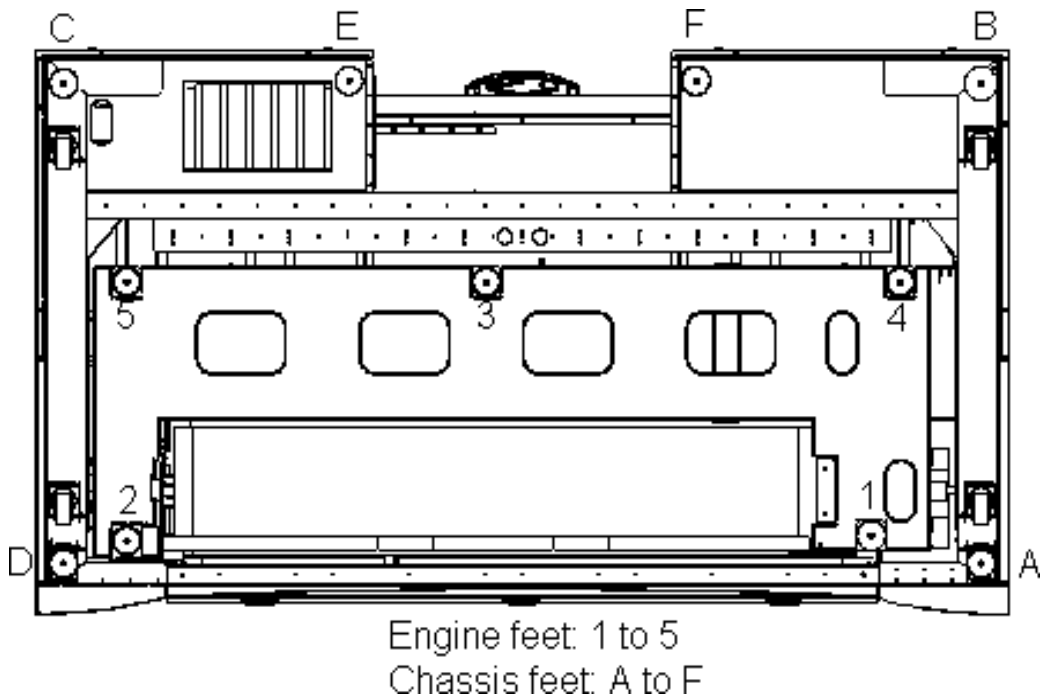

Figure 3: Top view of ThermoFlex Wide II foot layout

Debris Removal Cabinet

Certain printing media (plates or film) may release airborne emissions during the imaging process. Kodak output devices are supplied with—or may be able to be upgraded to—a debris removal system containing a collection nozzle located on the thermal head and a filtration unit, such as the Universal Debris Removal Cabinet (UDRC).



WARNING: Emissions, either particulate or gaseous, that are not properly filtered can endanger your health. For a list of airborne emissions that pertain to the media you are using, refer to the media MSDS or contact the media manufacturer or distributor directly.

The debris removal system is designed to extract and filter the airborne emissions, thus contributing to a healthier working environment, consistent image quality, and general reliability and cleanliness of the imaging device. Some types of media typically release both particulate and gaseous emissions. Other types of media, under certain imaging conditions, may release largely particulate emissions.



WARNING: Filtration of airborne emissions is not 100% efficient and must be complemented by adequate outdoor air room ventilation. Failure to ensure adequate ventilation may result in exposure to airborne emissions in excess of applicable regulatory limits and in possible discomfort, illness, injury, and/or disability.

The UDRC configuration may include various filter options tailored to suit specific qualified media types. The configuration for a particular customer site is typically specified in a Kodak proposal, sales agreement, order form, product specification, or equivalent document.

The cabinet must be located within the cable and hose limitations.

For more information on the debris removal cabinet, please refer to the *UDRC Site Preparation Guide* (part number 725-00089A).

Environmental Conditions

Install the device in a clean prepress area wherever possible to ensure the highest quality output. If you must install the device in a pressroom environment, an enclosed room is mandatory.

Operating environment for the device:

Temperature 17°-25° C (63°-77 °F)

Humidity 30%-70% RH, non-condensing

Note: Some media types may restrict the operating environment of the system. Consult the media manufacturer for their recommended temperature and humidity ranges for media use and storage.

For the UDRC operating environment, see the *UDRC Site Preparation Guide* (part number 725-00089A).

Floors

The floor must be level, with a maximum incline or waviness of ± 12.5 mm (± 0.5 in.) across the footprint. The maximum floor loading specifications for the device are:

- Maximum concentrated load: 400 kg (880 lb.)
- Loading pressure: 635 kPa (92 psi) (per area of one support foot)
- Floor load (average): 260 kg/m^2 (53 lb./ft.^2)

The device is suitable for mounting on a concrete floor or other non-combustible floor material only, extending a minimum of 150 mm (5.9 in.) around the perimeter of the machine.

The floor loading specifications for the pedestal's Hilti® bolts are 13790 kPa (2000 psi) in North America. For installation in Europe, contact the local Hilti dealer for their *Technical Guide for Concrete Strength* to ensure adequate concrete strength.

Floor Vibration

If the customer site is close to heavy vehicle or rail traffic routes, or is near an industrial site, the ThermoFlex device may be exposed to high levels of vibration through the floor. The customer is responsible for hiring an independent contractor to conduct floor vibration tests to determine the level of vibration. These tests will show what shock acceleration will get transmitted to the ThermoFlex device during imaging. The results of the vibration test must be sent to a Kodak representative for further analysis.

Recommendations on how to check the vibration levels are shown below:

1. Hook up an accelerometer probe with a sensitivity of 1000 mV/g (such as the Kistler® PiezoBEAM® accelerometer, Model 8628B5) to a signal analyzer.
2. Attach the probe to a metallic block that is approximately 50 mm³ (2 in.³).
3. Place the block on the floor where the output device will be installed so that vibration in the vertical direction can be measured.
4. Set the analyzer range to 0–200 Hz (x-axis) and 0–10 mg (y-axis).
5. Measure and record the floor vibration spectrum from 0–200 Hz when there are maximum peaks of seismic activity at the site.
6. Repeat step 5 at least 5 times.

Test result guidelines:

- 0 to 2 milli-g's acceleration (0-200 Hz)—no image artifacts expected.
- 2 to 10 milli-g's acceleration (0-200 Hz)—requires analysis of specific frequency peaks and amplitudes.
- Greater than 10 milli-g's (0-200 Hz)—very high probability of image artifacts.

Electrical

The dedicated branch circuit for the output device main power, external chiller power, debris removal system main power, and workstation main power must be supplied from the same AC supply panel to ensure that all branch circuits are at the same ground potential.

Figure 4 shows the configuration of the receptacles used by the device and peripheral equipment.

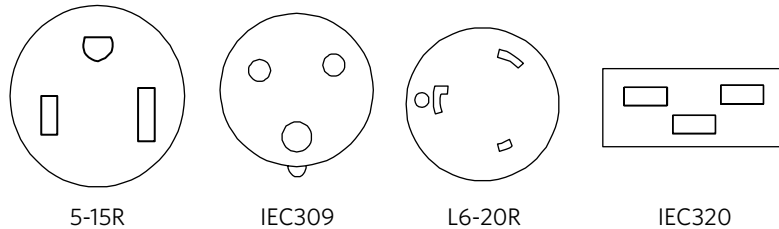

Figure 4: Receptacles used on ThermoFlex Wide devices

See the *UDRC Site Preparation* document (725-00089A) for information on UDRC electrical connections.

Power Quality

If you suspect that there are problems with the power supply, a power monitor should be installed to measure power quality. If the power supply is unreliable, a line conditioner may be required. If power in the local area is suspect, check with the local service.

If the power quality at the customer site is outside Kodak specifications (+6%/-10%), the customer should purchase a line conditioner for the ThermoFlex Wide II circuit from a local supplier.

If there are concerns about power quality (blackouts or brownouts) at the customer site, an online uninterruptible power supply (UPS) device can be purchased from a local supplier. A UPS allows a correct, complete shutdown of the device. (A line conditioner allows the device to function for extended periods of time when the power conditions are outside of the ThermoFlex Wide II specifications.)

Note: A UPS does not provide adequate line conditioning.

UPS specifications are available from the supplier.

Special Precautions

The plugs on the power cord(s) of the system are intended to be the disconnect device. Therefore, the branch circuit receptacle(s) must be installed near the ThermoFlex Wide II and be easily accessible.

Heat Output

The nominal heat output of the ThermoFlex Wide II device itself is 2200 watts (7513 BTU/hr.), while the drum vacuum pump gives off approximately 5600 watts (19220 BTU/hr.) of additional heat.

For heat output of the debris cabinet, see the *UDRC Site Preparation Guide* (part number 725-00089A).

Power Line Voltage/Frequency

Line voltage at the customer site must remain within +6%/-10% of the ThermoFlex Wide II rated voltage of 200 V-240 V, or between 180V and 254 V. The frequency is 50/60 Hz \pm 1.5%.

The electrician at the customer site should install the correct outlet to provide power to the device. The device must be powered from a different line than the workstation. Tolerances for the specified input voltages require balanced power inputs (L1-G=L2-G, or L1G=L1-N).

Power connectors must be the locking type in North America and Industrial type B in Europe, due to the high leakage current of the equipment. Frequency is 50/60Hz \pm 1.5%.

Power Line Disturbances

The reliable operation of computer systems depends on the availability of relatively noise-free AC power. Lightning, line faults, or power switching, commonly found in machinery or equipment in office or factory environments, can generate line transients that far exceed the peak value of the applied voltage. If not attenuated, these microsecond pulses can disrupt system operation. The power line to the machine should be run away from electrically noisy power cables. If power line disturbances are affecting the operation of the machine, the use of a power stabilizer is highly recommended.

Dips in power should not exceed 30% of nominal voltage with a maximum duration of 10 ms. Fast transient disturbances on the power line should not exceed 1.0 kV.

Air Supply

The output device requires a clean, dry, *oil-free*, *dust-free*, and *moisture-free* air supply of 1130 liters/min @ 827 kPA (40 SCFM @ 100 psi dynamic minimum to 120 psi dynamic maximum) of shop air, not to exceed 120 psi static.¹

A screw-type or scroll-type compressor is preferred. The air supply should conform to ISO 8573-1 Class 4.

- Maximum particle size 15 μ m (0.0006 in.)
- Concentration of solid contaminants: 8 mg/m³ (0.000216 oz./yd.³)
- Maximum pressure dew point 3°C (37.4°F)
- Maximum oil content 5 mg/m³ (0.000135 oz./yd.³)

Note: Do not add lubricant.

Ventilation

No filtration can be 100% efficient (for example, carbon monoxide is not captured by Kodak filters). That is why outdoor air ventilation is required with the debris removal system. Air exhaust vents (where air is drawn out of the room) should be located as close to the debris removal cabinet and output device as possible.

The ThermoFlex Wide II device requires a minimum of 340 m³/hr (200 cfm)² outdoor air ventilation. This air ventilation prevents the accumulation of airborne emissions that may be released when certain media are imaged.³

Outdoor air ventilation must not be confused with air circulation in the room that results from temperature control or humidity control. Outdoor air ventilation may be roughly estimated to be 10% to 30% of the air circulation rate in the room. To achieve adequate air mixing, Kodak recommends at least 3 ACH (air changes per hour).

These recommendations apply to a single device with no other equipment in the room. Other imaging equipment, processors, ovens, HVAC systems, and so on, may contribute additional emissions to the work environment, increasing the amount of outdoor air ventilation required.

The customer is responsible for assessing the level of airborne emissions in the room to ensure that, upon installation of the ThermoFlex Wide II, the requirements of local, state, provincial, regional, and national regulations for occupational health and safety are satisfied. In the event of any uncertainty about the levels of airborne emissions, the customer should arrange for an indoor air quality assessment to be conducted by a qualified industrial hygienist.

1. Guidelines for achieving these specifications for air cleanliness, volume and pressure are provided in *Air Compressors for Creo Output Devices* (part number 750-00006A).
2. This is a default value. Certain media may require higher ventilation; to check the recommended value for specific media, refer to the *CTP Media Imaging Performance Database* (available from your Kodak representative).
3. Information on the hazardous compounds released by a particular media during imaging should be available from the media manufacturer's Material Safety Data Sheet or equivalent document.

External Venting for Debris Removal System

If the external venting option is chosen for the debris removal system, the piping connected to the end of the debris cabinet hose shall be limited to one of:

1. 2 in. pipe (maximum Schedule 40)
 - maximum length = 45 m (150 ft.)
 - maximum number of 90° bends/elbows = 1 per 3 m (10 ft.)

OR
2. 2 1/2 in. pipe (maximum Schedule 40)
 - maximum length = 105 m (350 ft.)
 - maximum number of 90° bends/elbows = 1 per 3 m (10 ft.)

OR
3. 3 in diameter or larger ducting
 - maximum length = 240 m (800 ft.)
 - maximum number of 90° bends/elbows = 1 per 3 m (10 ft.)

Note: Option 3 is not recommended due to sealing issues. It may be used if there is an exhaust fan installed that ensures a vacuum within the ductwork at all times (the minimum flow of the exhaust fan must be greater than 35 SCFM).

The piping material may be galvanized steel, painted carbon steel, PVC, or a similar suitable material.

All joints and unions from the hose coupling to the exhaust/exit of the external venting piping shall be properly sealed along their length to prevent ingress or egress or any gas or liquid. Before initial startup, it is recommended that a pressure test be performed to ensure that this requirement is met.

The exhaust/exit of the external venting piping will be free to the exterior of the building, without any restrictions. Adequate non-restrictive weather protection shall be installed as required. The exit of the external venting piping must be regulated to ensure that no flow occurs when the debris cabinet is not in operation (i.e., back-flow prevention).

The customer shall supply a coupling to connect the external venting piping with the 1.5 in ID hose from the debris cabinet. This coupling should install by simply slipping the hose over a braided section of it and securing it with a hose clamp.

Connecting to an Existing Ventilation System

If the customer already has a ventilation system that exhausts to the exterior of the building (such as a processor exhaust system), the venting piping for the debris system may be joined to it. The end of the debris system venting pipe should be mated to the exhaust vent upstream of the ventilation fan, as follows:

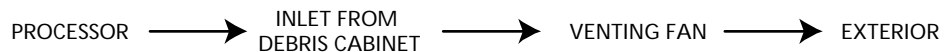

The limitations on pipe length described above apply.



WARNING: The exhaust fan for processor ventilation must be ON at the same as the debris removal system is ON (i.e., whenever the imaging device is operating). Failure to ensure this may result in air that has not been chemically treated entering the facility.

Drum Vacuum System

The drum vacuum system consists of the drum vacuum pump and the drum vacuum drive. The drum vacuum system connections to the ThermoFlex Wide output device are shown in Figure 1 on page 8.

Drum Vacuum Pump

The drum vacuum pump enclosure has the following features:

- Splash-proof design for interior or exterior installation
- Acoustic insulation that limits attenuation to 70 dB
- Integrated cooling fan and removable air filter at intake duct

Location

Because the drum vacuum pump generates a significant amount of heat during normal operation, the enclosure should not be installed in the same room as the output device.

The preferred location for the drum vacuum pump enclosure is an equipment room that is thermally insulated from normal working areas in the building, and that has forced ventilation or cooling. Alternatively, the pump may be mounted outside *if* the environmental conditions can be maintained within acceptable limits.

When selecting a location, consider the following:

- Ambient air temperature around the enclosure must not exceed 40° C (104° F) and must not go below -5° C (23° F). Adequate ventilation must be provided to keep the temperature below the upper limit.
- There must not be prolonged exposure to direct sunlight.
- The intake and exhaust ports (ends of the enclosure) must have at least 300 mm (12 in.) clearance from all obstacles to allow the cooling air to flow freely.
- There must be shelter from snow, ice and any debris that may impede the free flow of cooling air.
- There must be service access for changing the intake filter and removing the cover fasteners along the sides.
- The maximum length of tubing needed to reach the output device should be 15.2 m (50 ft.).

For exterior installations, a shed or shelter should be provided to protect against debris and solar heating.

Installation

The drum vacuum pump enclosure should be installed on a concrete pad, or a solid base, to which the enclosure can be fastened. The pump enclosure should be permanently mounted to the floor using four bolts or studs through four 1/2 in. (12.7 mm) holes in the enclosure base. The enclosure footprint and the layout of the mounting holes is shown in Figure 5.

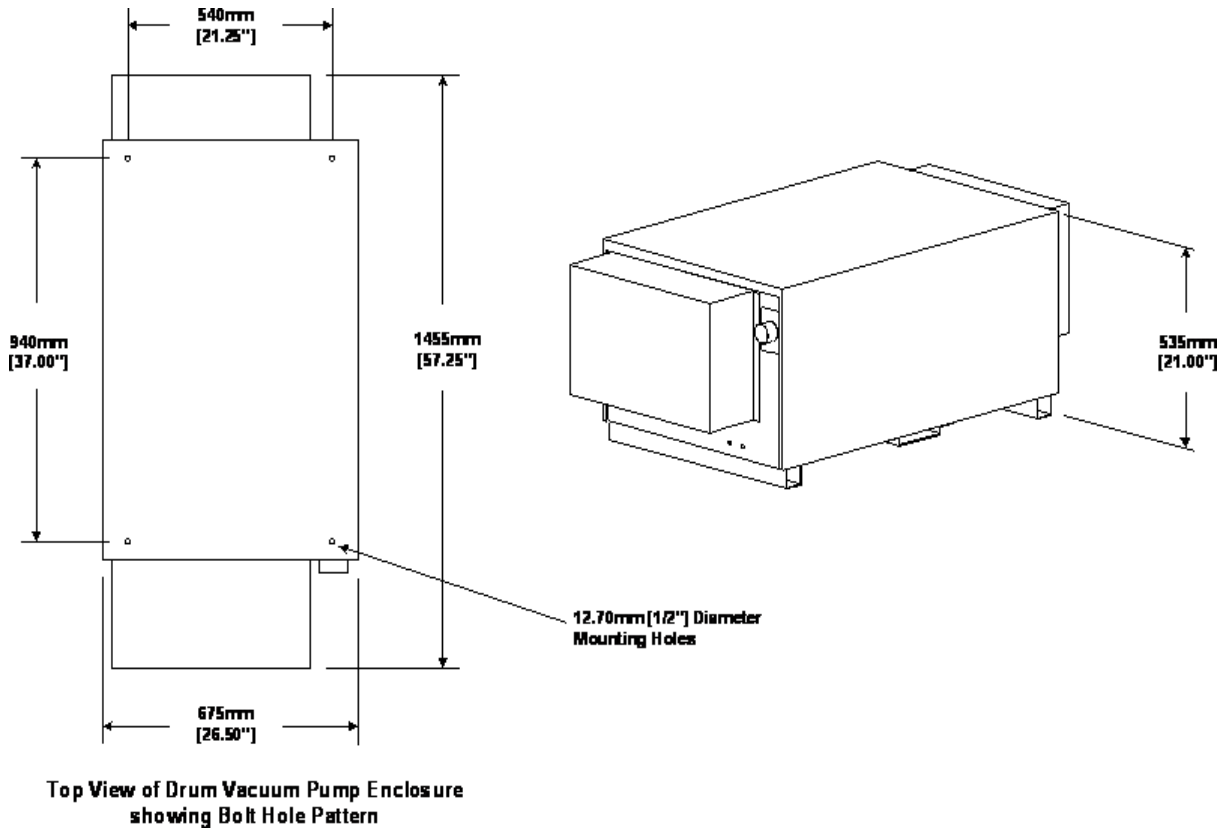

Figure 5: Drum vacuum pump enclosure

Tubing (Pump to Output Device)

Where possible, it is strongly recommended that the line from the drum vacuum pump be hard-piped to improve the performance of the system. Use 2 in. Schedule 40 PVC tubing from the drum vacuum pump to the output device.

Kodak supplies 15.2 m (50 ft.) of 2 in. ID flexible vacuum hose to connect the vacuum pump with the output device. This is the maximum length permissible without degrading the media-holding performance of the pump. If PVC piping is used, the total allowable vacuum line length (length of piping plus length of flexible hose) may be increased to 18.3 m (60 ft.). Keep the number of fittings to a minimum and use long-radius PVC conduit elbows. The customer is responsible for supplying and installing any PVC vacuum piping for the drum vacuum system.

Drum Vacuum Drive

The drum vacuum drive panel assembly must be mounted indoors on a vertical wall or surface within 7.6 m (25 ft.) of the output device. It must be secured with four screws through the four 8.5 mm (11/32 in.) holes in the back of the drive panel.

The drive panel weighs approximately 25 kg (55 lb.). If it is being mounted on a partition wall, it must be screwed either to wooden blocks inside the wall, or it must be screwed to a small sheet of plywood that has been securely screwed into the studs of the partition wall. Adequate space on both sides of the drive panel is required to allow for cooling of the assembly through the panel louvers.

When selecting a location, consider the following:

- The drum vacuum drive must be mounted on an interior vertical wall or surface.
- The 7.6 m (25 ft.) long control cable must reach the output device.
- The 15.2 m (50 ft.) long power/control cable must reach the drum vacuum pump.
- The customer-supplied branch circuit wiring must enter through the top.
- The ambient air temperature must not exceed 35° C (95° F).

The mounting-hole pattern, and panel dimensions are shown in Figure 6.

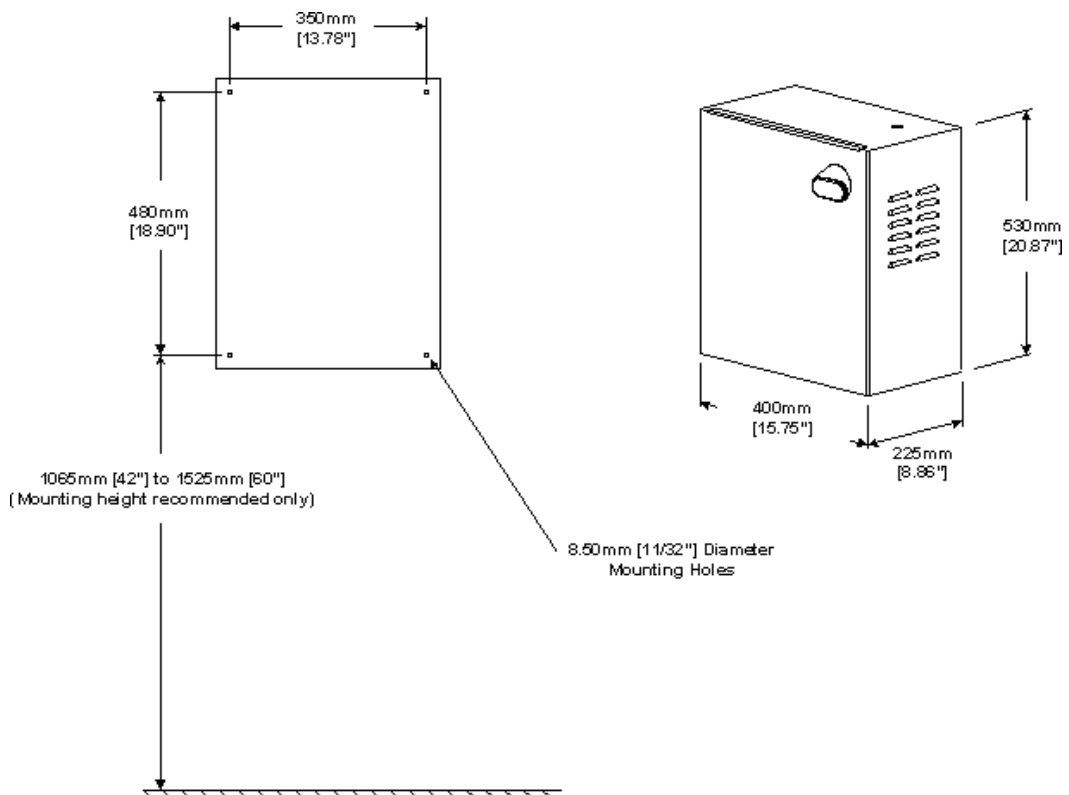

Figure 6: Drum vacuum drive panel

Telephone Link

The customer must maintain a “direct dial” analog telephone line that is dedicated to the workstation (no other devices sharing this line) for use with Kodak remote support. See Tables 2–4 for the required phone jack connector. The customer should also provide a separate voice telephone line to the output device location for communication with service representatives during remote support.

Note: Remote dial-in support to the output device is dependent upon a dedicated, direct dial-in telephone line. Kodak can only offer remote support to devices that do not share telephone lines with other equipment.

Network

A total of four TCP/IP addresses must be provided for each ThermoFlex Wide II device:

- One local area network (LAN) connection to the output device for supplying files from the workstation. See Table 5 on page 7 for supported network interfaces.
- Three consecutive static TCP/IP addresses for the output device-workstation connection:
 - ❑ One for the workstation end of the PPP connection
 - ❑ One for the MCE (master control electronics) end of the PPP connection
 - ❑ One for the RAS (remote access services) connection

Note: The customer must ensure that the three addresses are removed from the available addresses in the dynamic host configuration protocol (DHCP) pool.

Media and Processor(s)

The customer must provide an appropriate supply of media and processor(s) with an adequate supply of development chemistry, water, and drain/electrical connections as specified by the manufacturer.

The customer must provide a list of all media sizes and types to be used.

Note: This does not apply where chemistry-free plates are being used.

Shipment and Delivery

Responsibilities

The customer must provide Kodak with delivery instructions, and the customer must transport all of the shipping crates to the installation location and unload the shipping crates. However, the customer must not unpack the shipping crates. Kodak recommends that the customer use professional riggers to unload the crates. Dock level (a vertical distance from ground to dock of 1.2 m (4 ft.)), and the ability to handle a 15.9 m (53 ft.) trailer are required.

Kodak representatives will unpack the shipping crates and install the device.

Forklift

The customer must provide a forklift or crane with a minimum 2300 kg (5000 lb.) capacity for unloading of the equipment. The forks must be 1140 mm (45 in.) long and a maximum of 152 mm (6 in.) wide. The span should be approximately 580 mm (23 in.).

The forklift must be capable of safely lifting the device and crate with the center of gravity as shown in Figure 7.

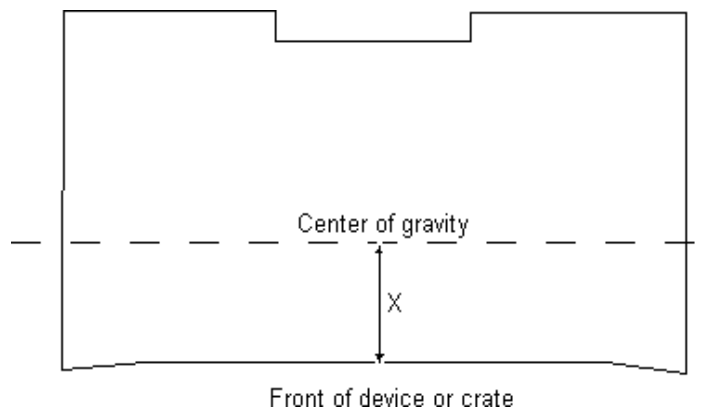

Ground crate with device:	X=860 mm (34 in.)
Air crate with device:	X=890 mm (35 in.)
Device only:	X=710 mm (28 in.)

Figure 7: Center of gravity for lifting device

The forks must be inserted from the front and should be centered on the length of the device. The output device is equipped with casters, so it may be rolled into position once it is on the ground.

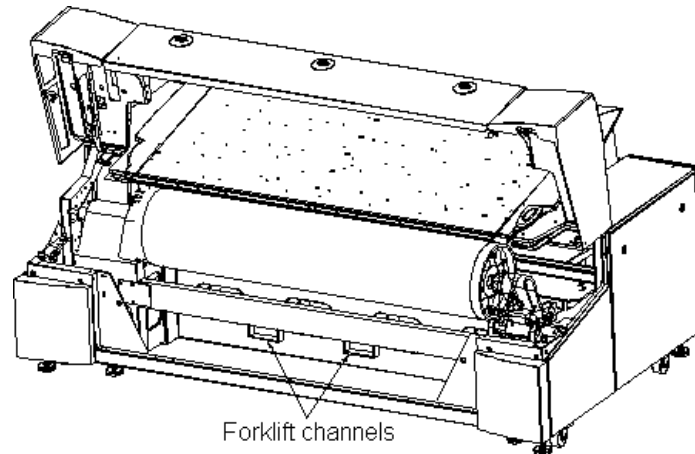

Figure 8: Lifting points



WARNING: Lift the machine *only* by inserting the forks in the engine casting. Do *not* attempt to lift the device from underneath. Ensure that the cable track on the back of the engine casting is not in the way of the forklift channels in the engine casting.

Doors and Hallways

The customer must provide free access through doors and hallways from the entrance to the ThermoFlex Wide II location so that the whole pallets can be transported to the installation location. Kodak recommends that the customer furnish a drawing of the route. See *Shipping Crates* on page 23 for maximum crate dimensions.

Once the components are uncrated, they may be moved through smaller doorways. See Table 1 on page 3 for dimensions of individual components.

Note: Walk the entire route from the loading dock to the installation area. Measure all doorways, openings and aisles to ensure that there is adequate space to move all of the components safely.

Shipping Crates

The output device is normally shipped in 10 crates. Table 6 lists the individual dimensions (L x W x H) and weights of air-shipped crates. Table 7 lists the individual dimensions (L x W x H) and weights of ground-shipped crates.

Table 6: Dimensions and weights of crates (air shipment)

Crate Contents	Length	Width	Height	Weight
ThermoFlex Wide II output device	3560 mm (140 in.)	2080 mm (82 in.)	1700 mm (67 in.)	2022 kg (4450 lb.)
Thermal head	870 mm (34 in.)	870 mm (34 in.)	870 mm (34 in.)	75 kg (165 lb.)
Workstation	Varies with configuration			
Debris removal cabinet	Refer to the <i>UDRC Site Preparation Guide</i> (part number 725-00089A).			
Drum vacuum drive assembly	610 mm (24 in.)	610 mm (24 in.)	460 mm (18 in.)	31 kg (68 lb.)
Drum vacuum pump assembly	1650 mm (65 in.)	870 mm (34 in.)	890 mm (35 in.)	216 kg (475 lb.)
Pedestal	1630 mm (64 in.)	760 mm (30 in.)	1250 mm (49 in.)	182 kg (400 lb.)
Transport cart	2010 mm (79 in.)	890 mm (35 in.)	1500 mm (59 in.)	182 kg (400 lb.)
Pedestal shaft	2570 mm (101 in.)	305 mm (12 in.)	200 mm (8 in.)	50 kg (110 lb.)
Arbor	2360 mm (93 in.)	430 mm (17 in.)	530 mm (21 in.)	109 kg (240 lb.)

Table 7: Dimensions and weights of crates (ground shipment)

Crate Contents	Length	Width	Height	Weight
ThermoFlex Wide II output device	3480 mm (137 in.)	2060 mm (81 in.)	1600 mm (64 in.)	1930 kg (4250 lb.)
Thermal head	820 mm (32 in.)	820 mm (32 in.)	820 mm (32 in.)	45.5 kg (100 lb.)
Workstation	Varies with configuration			
Debris removal cabinet	See the <i>UDRC Site Preparation Guide</i> (part number 725-00089A).			
Drum vacuum drive assembly	610 mm (24 in.)	610 mm (24 in.)	460 mm (18 in.)	31 kg (68 lb.)
Drum vacuum pump assembly	1650 mm (65 in.)	870 mm (34 in.)	890 mm (35 in.)	216 kg (475 lb.)
Pedestal	1600 mm (63 in.)	760 mm (30 in.)	1190 mm (47 in.)	159 kg (350 lb.)
Transport cart	1980 mm (78 in.)	870 mm (34 in.)	870 mm (34 in.)	182 kg (400 lb.)
Pedestal shaft	2570 mm (101 in.)	305 mm (12 in.)	200 mm (8 in.)	50 kg (110 lb.)
Arbor	2360 mm (93 in.)	430 mm (17 in.)	530 mm (21 in.)	109 kg (240 lb.)

Appendix A: Notice

The imaging of some media may result in airborne emissions. This notice is intended to provide general information relating to these emissions only. For information specific to particular media, please refer to the media manufacturer's MSDS or other documentation.

The by-products of the imaging of printing media may include one or more of: aldehydes (formaldehyde, acetaldehyde); oxides (nitrogen dioxide, nitric oxide, carbon monoxide); volatile organic compounds and olefins (benzene, 1,3-butadiene); other gaseous compounds (hydrogen cyanide, and so on); and particulate matter (dust). This list is not comprehensive, and other compounds may be present in the emissions, depending on particular media.

To help prevent contamination and to improve reliability of imaging, the Kodak output device may include a debris removal system containing a filtration unit, either internal or external (for example, a universal debris removal cabinet), corresponding to qualified media used at a particular site. Depending on the configuration of the filtration unit, the unit may trap dust only (for example, UDRC-BP), or it may trap dust and a number of gaseous by-products of the imaging process (for example, UDRC-LC). It is critical to change the filters in the filtration unit on a regular basis.

Not all emissions can be efficiently captured by filtration. Sufficient outdoor air ventilation must be provided in rooms where Kodak output devices and filtration units are located. The requirements to ventilation rate are contained in either the output device *Site Preparations and Requirements* document or another applicable document.

Kodak cannot assure occupational safety under all operational conditions because of factors that are outside the control or knowledge of Kodak. These factors include, but are not limited to:

- Inadequate air ventilation or poor air mixing in the imaging room, which may cause higher than expected emissions concentrations in all or parts of the room
- Imaging of media that were not qualified or pre-approved by Kodak; in particular, media not qualified for use with a debris removal system or a filtration unit specified in the Kodak Sales Agreement, Customer Agreement, Order Form, Service Agreement, Output Device Configuration, or similar applicable document
- Changes to the qualified printing media formulation or manufacturing process made by the media manufacturer after qualification, resulting in emissions changes (this may cause different or greater emissions than expected)
- Incorrect or incomplete specification of potential emissions to Kodak by the media manufacturer, which may cause different or greater emissions than expected
- Combined action of airborne emissions from multiple compounds, which may—through cumulative or synergistic effects—cause greater than expected effects on human health
- Airborne emissions from other sources combining with the imaging system's emissions to exceed occupational health regulations or having cumulative effects on human health greater than those expected for individual emissions
- Variation in individual sensitivity to airborne emissions that may cause greater effects in susceptible individuals
- Tampering with, misuse of, or incorrect maintenance of imaging equipment or emissions safety systems, which may cause additional emissions to occur
- Non-compliance with instructions in user guides, warning labels, site preparation, or other Kodak documents, which may cause excessive emissions levels
- Changes in occupational health regulations or industrial hygiene practices that may result in a system that is considered safe upon original installation, but is found to be unsafe at a later date.

Because of variables such as those listed above, many of which are in the control of the end user or the media manufacturers, Kodak cannot warrant that, under all imaging system installations and operating conditions, including the use of a filtration unit, and with all media types, media will not release emissions while being imaged that an operator or other persons may find objectionable or may claim to be injurious. KODAK'S ONLY WARRANTY AND LIABILITY, IF ANY, SHALL BE AS PROVIDED UNDER ITS STANDARD TERMS OF SALE OR CUSTOMER AGREEMENT, AS APPLICABLE. Neither this notice nor the *Site Preparations and Requirements* document or other similar document is a promise or guarantee of a particular level of performance, and neither this notice nor the *Site Preparations and Requirements* document or other similar document is a warranty of any kind whatsoever. It is the end user's responsibility to ensure continuing compliance with all Occupational Health and Safety regulations and guidelines in its work environment.

Appendix B: Site Inspection Checklist

Full completion of this checklist will greatly assist in building, delivering, and installing the ThermoFlex Wide II and all its accessories.

Site Information

Company name: _____

Site address:

Shipping address:

Directions to site:

Nearest airport:

Local hotels:

Local restaurants:

Contact Information

Contact name: _____

Position: _____

Telephone/fax: _____

E-mail: _____

Prepress manager: _____

Maintenance manager: _____

Network manager: _____

Device operators: _____

General background and computer skills of operators:

--

Note: All operators must be capable of running a personal computer with a Microsoft® Windows® operating system. If there are more than four operators to be trained, an extra day will be required after the installation.

Machine Usage

Number of shifts per day: _____
 Shift 1 hours: _____
 Shift 2 hours: _____
 Shift 3 hours: _____
 Shift 4 hours: _____

Media Supported

List all media types and sizes to be used for each device.

Measurements are in:

mm in.

Media type ^{a,b}	Plate size	Average # of plates per day	Average length of press run	Type of work (4-color; spot color; halftones; Staccato [®] ; text only)

- a. Kodak-approved media only. Imaging speed can be affected if media sensitivity or processing is inconsistent with Kodak’s qualification testing. See your Kodak representative for specific media information.
- b. Some plates may restrict the operating environment of the system. Consult the plate manufacturer for their recommended temperature and humidity ranges for plate operation and storage.

Press(es) Supported

Press name and model: _____

Processor Supported

Processor name and model: _____
 Delivery date: _____

Has the customer met the power and plumbing requirements for the processor?

Yes No

Comments:

Other Kodak Equipment On Site

Are any other Kodak products already installed?

Yes No

Comments:

Will Kodak be installing other new equipment during the installation of the ThermoFlex Wide II?

Yes No

If yes, what will be installed?	When?	Who at Kodak is doing the install?

Other Non-Kodak Equipment in Prepress Room

Are any other non-Kodak products already installed in the prepress room?

Yes No

Comments:

Planned Installations Nearby

Will any other new equipment be installed in the vicinity of the device (for example, a processing line)?

Yes No

If yes, what will be installed?	When?	Who is doing the install?

Output Device Configuration

Model of output device (check the model that applies):

4836 4260 5280

F Speed V Speed

Type of workstation ordered: _____

Type of workflow ordered: _____

Site Requirements

Note: Install the device in a clean prepress area.

1. Is there sufficient space for the device? Measure the available space at the site location. (See *Footprint and Working Area* on page 9.)

Yes No

Comments:

2. Is the working area free from support beams or other obstacles?

Yes No

Comments:

3. Does the mounting location of the drum vacuum pump enclosure meet the requirements? (See *Drum Vacuum Pump* on page 17.)

Yes No

4. Does the routing of any customer-installed PVC drum vacuum piping meet the requirements? (See *Tubing (Pump to Output Device)* on page 18.)

Yes No

5. Does the customer know that they are responsible for transporting shipping crates from their shipping dock to the installation area?

Yes No

6. Does the forklift to be used meet requirements? (See *Forklift* on page 21.)

Yes No

- 7. Will the doors and hallways between the shipping dock and the installation area allow passage of the shipping crates? (See *Doors and Hallways* on page 22.)

Yes No

Comments:

- 8. Can the receiving area accommodate a typical air ride truck—that is, does it have dock level? (See *Shipment and Delivery* on page 21.)

Yes No

Comments:

- 9. What is the expected range of temperature in which the device will be used?

Temperature range: _____

- 10. Can the room’s temperature control system handle the heat load generated by the device and the processor line? (See *Heat Output* on page 14.)

Yes No

Comments:

- 11. What is the expected humidity range in which the device will be used?

Humidity range: _____

12. Can the room's humidity control system handle the moisture load generated by the processor line?

Yes No

Comments:

13. Is the installation area flat to the required specification? (See *Floors* on page 11.)

Yes No

Comments:

14. Does the floor meet the maximum peak loading specification? (See *Floors* on page 11.)

Yes No

Comments:

15. Is there large machinery or a forklift thoroughway inside the site, or any traffic or industry near the site that may transmit vibration to the device? (See *Floor Vibration* on page 12.)

Yes No

Comments:

16. What are the AC mains voltages?

AC mains voltage for workstation: _____

AC mains voltage for device: _____

AC mains voltage for the drum
vacuum pump _____

17. Is power conditioning required?

Yes No

If yes, has a line conditioner been ordered?

Yes No

18. Is UPS required?

Yes No

If yes, has the UPS been ordered?

Yes No

19. Are a 20 A service (16 A in Europe) with a slow-blow fuse or breaker and a dedicated ground installed for the device?

Yes No

Comments:

20. Is the AC service for the workstation installed and originating from the same supply panel as the device AC service?

Yes No

Comments:

21. Is the air supply filtered and dried as per specification? (See *Air Supply* on page 15.).

Yes No Prefilter ordered

Comments:

22. Are the voice and data telephone lines installed?

Yes No Modem number: _____

Comments:

23. What type of network connection is used?

24. What are the three consecutive TCP/IP addresses that are to be used for the MCE and RAS connection? (See *Network* on page 20.)

- 1. _____
- 2. _____
- 3. _____

Follow Up

Is follow-up required?

No The location described in this document meets all criteria for a timely and successful installation of the ThermoFlex Wide II device.

Yes Some follow-up is required to ensure that the site requirements are met prior to the installation of the device.

The outstanding items from the Site Requirements list are:

Name of customer contact: _____
Telephone/fax: _____
E-mail: _____
Date of next follow-up contact: _____

Site Inspection Completed

The presite inspection was performed on _____ by a representative of Kodak and witnessed by at least one representative of the customer.

Kodak representative: _____

Signature: _____

The Customer understands and hereby agrees to the requirements outlined in the *ThermoFlex Wide II Site Preparation Guide* (part number 725-00093A-C-PR01) and the *Universal Debris Removal Cabinet Site Preparation Guide* (part number 725-00089A), including any appendix attached thereto, as acknowledged by the Customer's signature herein or, alternatively, by the customer's signature on a Sales Agreement, Customer Agreement, Service Agreement, Order Form, or similar applicable document.

Customer representative: _____

Signature: _____